

RESOLUTION NO. _____

A resolution authorizing Tennessee Football, LLC to construct, install, and maintain aerial encroachments at South Second Street. (Proposal No. 2026M-021EN-001).

WHEREAS, South Second Street is currently under construction in connection with the new Titans stadium located at 1 Titans Way; and,

WHEREAS, Tennessee Football, LLC plans to construct, install and maintain 24-inch banner arms with 4-inch mounting collars on light poles that will be located along South Second Street, for the purpose of hanging banners, encroaching into the public right-of-way at South Second Street; and,

WHEREAS, as set forth in the License Agreement for Private Encroachments Into the Public Right of Way, attached hereto as "Exhibit A", and incorporated by reference herein, Tennessee Football, LLC has agreed to indemnify and hold the Metropolitan Government of Nashville and Davidson County harmless of any and all claims for damages of every nature and kind resulting from or arising from the installation of said aerial encroachments; and,

WHEREAS, Metropolitan Code of Laws §13.16.030(A) allows the Council of the Metropolitan Government of Nashville and Davidson County to grant encroachments, permits, or privileges to construct, maintain and/or operate aerial encroachment cables, canopies, etc., over and/or across sidewalks and public rights-of-way by resolution adopted by twenty-one (21) affirmative votes.

NOW, THEREFORE, BE IT RESOLVED BY THE COUNCIL OF THE METROPOLITAN GOVERNMENT OF NASHVILLE AND DAVIDSON COUNTY:

Section 1. That subject to the requirements, limitations and conditions contained herein, Tennessee Football, LLC is hereby granted the privilege to construct, install, and maintain aerial encroachments as described in Proposal No. 2026M-021EN-001, in accordance with the plans on file in the office of the Director of the Nashville Department of Transportation and Multimodal Infrastructure ("NDOT"), and attached hereto as Exhibit B.

Section 2. That the authority granted hereby for the construction, installation, operation, and maintenance of said aerial encroachments under Proposal No. 2026M-021EN-001 shall not be construed as a surrender by the Metropolitan Government of its rights or power to pass resolutions or ordinances regulating the use of its streets, or the right of the Metropolitan Government through its legislative body, in the interest of public necessity and convenience to order the relocation of said facilities at the expense of Tennessee Football, LLC .

Section 3. That construction and maintenance of said aerial encroachments under Proposal No. 2026M-021EN-001 shall be under the direction, supervision, and control of the Director of NDOT, and its installation, when completed, must be approved by said Director.

Section 4. That this Resolution confers upon Tennessee Football, LLC a privilege and not a franchise, and the Mayor and the Metropolitan Council herein expressly reserve the right to repeal this Resolution, whenever, in their judgment, a repeal may be demanded by public welfare, and such repeal shall confer no liability on the Metropolitan Government of Nashville

{N0774278.1}

and Davidson County, its successors and assigns, by reason of said repeal. In the event of such repeal by said Metropolitan Government, Tennessee Football, LLC , its successors and assigns, shall remove said aerial encroachments at their own expense.

Section 5. Tennessee Football, LLC shall pay all costs incident to the construction, installation, operation and maintenance of said aerial encroachments under Proposal No. 2026M-021EN-001, and shall save and hold the Metropolitan Government of Nashville and Davidson County harmless from all suits, costs, claims, damages or judgments in any way connected with said construction, installation, operation and maintenance of said aerial encroachments and shall not claim, set up or plead, as a defense, in the event of joint liability, with or without suit, that it and the Metropolitan Government were joint wrongdoers. Tennessee Football, LLC shall be responsible for the expense, if any, of repairing and returning the right-of-way to the condition which it was in prior to the installation of said aerial encroachments, and for any street closure.

Section 6. That the authority granted to Tennessee Football, LLC , as herein described, shall not in any way interfere with the rights of the Metropolitan Government, its agents, servants, and/or contractors and utility companies, operating under franchise from the Metropolitan Government to enter, construct, operate, maintain, repair, rebuild, enlarge, and patrol its now existing or future utilities, including drainage facilities, together with their appurtenances, and to do any and all things necessary and incidental thereto.

Section 7. Tennessee Football, LLC shall and is hereby required to furnish the Metropolitan Government of Nashville and Davidson County a certificate of public liability insurance, naming the Metropolitan Government as an insured party, of at least two million (\$2,000,000) dollars aggregate, for the payment of any judgment had on any claim, of whatever nature, made for actions or causes of action arising out of, or connected with, the construction or installation of said aerial encroachments. Said certificate of insurance shall be filed with the Metropolitan Clerk and NDOT prior to the granting of a permit, and the insurance required herein shall not be canceled without the insurance company or companies first giving thirty (30) days written notice to the Metropolitan Government of Nashville and Davidson County.

Section 8. That said construction shall be carefully guarded and protected, and shall be completed promptly, so as to cause the least inconvenience to the public. The acceptance by Tennessee Football, LLC of all provisions of this Resolution shall be determined by the beginning of work.

Section 9. The authority granted pursuant to this Resolution shall not become effective until the certificate of insurance, as required in Section 7, has been posted with the Metropolitan Clerk and NDOT.

Section 10. This Resolution shall take effect from and after its adoption, the welfare of the Metropolitan Government of Nashville and Davidson County requiring it.

RECOMMENDED BY:

DocuSigned by:

AD2852A55F9C45F
Phillip Jones, Interim Director
Nashville Department of Transportation
and Multimodal Infrastructure

INTRODUCED BY:

APPROVED AS TO INSURANCE:

Signed by:

68804BF12FD741C
Insurance and Claims Manager

Member(s) of Council

APPROVED AS TO FORM
AND LEGALITY:

DocuSigned by:

D4F54A5815BD454...
Assistant Metropolitan Attorney

Proposal No. 2026M-021EN-001



CERTIFICATE OF LIABILITY INSURANCE

DATE (MM/DD/YYYY)
4/27/2026

THIS CERTIFICATE IS ISSUED AS A MATTER OF INFORMATION ONLY AND CONFERS NO RIGHTS UPON THE CERTIFICATE HOLDER. THIS CERTIFICATE DOES NOT AFFIRMATIVELY OR NEGATIVELY AMEND, EXTEND OR ALTER THE COVERAGE AFFORDED BY THE POLICIES BELOW. THIS CERTIFICATE OF INSURANCE DOES NOT CONSTITUTE A CONTRACT BETWEEN THE ISSUING INSURER(S), AUTHORIZED REPRESENTATIVE OR PRODUCER, AND THE CERTIFICATE HOLDER.

IMPORTANT: If the certificate holder is an ADDITIONAL INSURED, the policy(ies) must have ADDITIONAL INSURED provisions or be endorsed. If SUBROGATION IS WAIVED, subject to the terms and conditions of the policy, certain policies may require an endorsement. A statement on this certificate does not confer rights to the certificate holder in lieu of such endorsement(s).

PRODUCER Arthur J. Gallagher Risk Management Services, LLC Creekside Crossing 8 Cadillac Drive, Suite 200 Brentwood TN 37027	CONTACT NAME: Deb Canning PHONE (A/C, No, Ext): 615-377-5127 FAX (A/C, No): 615-377-5101 E-MAIL ADDRESS: Deb_canning@ajg.com														
INSURED Tennessee Football, LLC 460 Great Circle Rd Nashville, TN 37228	<table border="1" style="width: 100%; border-collapse: collapse;"> <thead> <tr> <th style="text-align: left;">INSURER(S) AFFORDING COVERAGE</th> <th style="text-align: left;">NAIC #</th> </tr> </thead> <tbody> <tr> <td>INSURER A : StarNet Insurance Company</td> <td>40045</td> </tr> <tr> <td>INSURER B : Nautilus Insurance Company</td> <td>17370</td> </tr> <tr> <td>INSURER C : Texas Mutual Insurance Company</td> <td>22945</td> </tr> <tr> <td>INSURER D : Great Divide Insurance Company</td> <td>25224</td> </tr> <tr> <td>INSURER E :</td> <td></td> </tr> <tr> <td>INSURER F :</td> <td></td> </tr> </tbody> </table>	INSURER(S) AFFORDING COVERAGE	NAIC #	INSURER A : StarNet Insurance Company	40045	INSURER B : Nautilus Insurance Company	17370	INSURER C : Texas Mutual Insurance Company	22945	INSURER D : Great Divide Insurance Company	25224	INSURER E :		INSURER F :	
INSURER(S) AFFORDING COVERAGE	NAIC #														
INSURER A : StarNet Insurance Company	40045														
INSURER B : Nautilus Insurance Company	17370														
INSURER C : Texas Mutual Insurance Company	22945														
INSURER D : Great Divide Insurance Company	25224														
INSURER E :															
INSURER F :															

COVERAGES **CERTIFICATE NUMBER: 778447640** **REVISION NUMBER:**

THIS IS TO CERTIFY THAT THE POLICIES OF INSURANCE LISTED BELOW HAVE BEEN ISSUED TO THE INSURED NAMED ABOVE FOR THE POLICY PERIOD INDICATED. NOTWITHSTANDING ANY REQUIREMENT, TERM OR CONDITION OF ANY CONTRACT OR OTHER DOCUMENT WITH RESPECT TO WHICH THIS CERTIFICATE MAY BE ISSUED OR MAY PERTAIN, THE INSURANCE AFFORDED BY THE POLICIES DESCRIBED HEREIN IS SUBJECT TO ALL THE TERMS, EXCLUSIONS AND CONDITIONS OF SUCH POLICIES. LIMITS SHOWN MAY HAVE BEEN REDUCED BY PAID CLAIMS.

INSR LTR	TYPE OF INSURANCE	ADDL INSD	SURRE VVD	POLICY NUMBER	POLICY EFF (MM/DD/YYYY)	POLICY EXP (MM/DD/YYYY)	LIMITS
B	<input checked="" type="checkbox"/> COMMERCIAL GENERAL LIABILITY <input type="checkbox"/> CLAIMS-MADE <input checked="" type="checkbox"/> OCCUR GENL AGGREGATE LIMIT APPLIES PER: <input checked="" type="checkbox"/> POLICY <input type="checkbox"/> PROJ SECT <input type="checkbox"/> LOC OTHER:			CLA 7500930 - 1B	3/1/2026	3/1/2027	EACH OCCURRENCE \$ 1,000,000 DAMAGE TO RENTED PREMISES (Per occurrence) \$ 1,000,000 MED EXP (Any one person) \$ 5,000 PERSONAL & ADV INJURY \$ 1,000,000 GENERAL AGGREGATE \$ 5,000,000 PRODUCTS - COMPROP AGG \$ 1,000,000 Liquor Liability \$ 1,000,000
A	<input checked="" type="checkbox"/> AUTOMOBILE LIABILITY <input checked="" type="checkbox"/> ANY AUTO <input type="checkbox"/> OWNED AUTOS ONLY <input type="checkbox"/> SCHEDULED AUTOS <input checked="" type="checkbox"/> HIRED AUTOS ONLY <input checked="" type="checkbox"/> NON-OWNED AUTOS ONLY			GAA 7500933 - 1B	3/1/2026	3/1/2027	COMBINED SINGLE LIMIT (Per accident) \$ 1,000,000 BODILY INJURY (Per person) \$ BODILY INJURY (Per accident) \$ PROPERTY DAMAGE (Per accident) \$ \$
D	<input checked="" type="checkbox"/> UMBRELLA LIAB <input checked="" type="checkbox"/> OCCUR <input type="checkbox"/> EXCESS LIAB <input type="checkbox"/> CLAIMS-MADE DEF RETENTION \$			CUA 7500920 - 1B	3/1/2026	3/1/2027	EACH OCCURRENCE \$ 5,000,000 AGGREGATE \$ 5,000,000 \$
C	<input checked="" type="checkbox"/> WORKERS COMPENSATION AND EMPLOYERS' LIABILITY ANY PROPRIETOR/PARTNER/EXECUTIVE OFFICER (NUMBER EXCLUDED)? (Mandatory in NH) If yes, describe under DESCRIPTION OF OPERATIONS below			0001154410	3/1/2026	3/1/2027	<input checked="" type="checkbox"/> PER STATUTE <input type="checkbox"/> OTHER E.L. EACH ACCIDENT \$ 1,000,000 E.L. DISEASE - EA EMPLOYEE \$ 1,000,000 E.L. DISEASE - POLICY LIMIT \$ 1,000,000

DESCRIPTION OF OPERATIONS / LOCATIONS / VEHICLES (ACORD 101, Additional Remarks Schedule, may be attached if more space is required)
 RE: Banner on future Second Street light poles near the stadium

CERTIFICATE HOLDER The Metropolitan Government of Nashville and Davidson County Metro Legal & Claims C/O Insurance and Safety Division 222 3rd Avenue North, Ste #501 Nashville, TN 37201	CANCELLATION SHOULD ANY OF THE ABOVE DESCRIBED POLICIES BE CANCELLED BEFORE THE EXPIRATION DATE THEREOF, NOTICE WILL BE DELIVERED IN ACCORDANCE WITH THE POLICY PROVISIONS. AUTHORIZED REPRESENTATIVE <i>Quay Stallworth</i>
---	--

© 1988-2015 ACORD CORPORATION. All rights reserved.

ACORD 25 (2016/03) The ACORD name and logo are registered marks of ACORD
 THIS CERTIFICATE SUPERSEDES PREVIOUSLY ISSUED CERTIFICATE

LICENSE AGREEMENT FOR PRIVATE ENCROACHMENTS
INTO THE PUBLIC RIGHT OF WAY

I/We, Dan Werly, SVP and COO,
Tennessee Football LLC, in consideration of the Resolution No. _____, to construct, maintain, install and/or operate an encroachment into, onto, over, or under the public right of way located at in Nashville, Davidson County, Tennessee, do hereby, for myself, my agents, customers, and assigns, waive and release and hold harmless The Metropolitan Government of Nashville and Davidson County, its agents, employees, and assigns from any and all claims, rights, or demands for damages that may arise from my/our use, construction and/or maintenance of the encroachment, to wit: (SEE ATTACHED DESCRIPTION OF ENCROACHMENT). I/We hereby certify to the Metropolitan Government of Nashville and Davidson County that I/We have executed a bond or liability insurance policy in such amount as agreed upon by the Director of NDOT and the Metropolitan Attorney, and in the form approved by the Metropolitan Attorney (per Metropolitan Code Section 38-1-1), which operates to indemnify and save The Metropolitan Government of Nashville and Davidson County harmless from all claims or demands that may result to persons or property by reason of the construction, operations or maintenance of the encroachment. I/We further agree that my/our obligations hereunder may not be assigned except upon approval of the Director of NDOT and the Metropolitan Attorney. I/We further acknowledge that any action that results in a failure to maintain said bond or liability insurance for the protection of The Metropolitan Government of Nashville and Davidson County shall operate to the granting of a lien to The Metropolitan Government of Nashville and Davidson County in the amount of the last effective bond/insurance policy. Said insurance or bond may not be cancelable or expirable except on 30 days' notice to the Director of NDOT.

I/We further recognize that the license granted hereby is revocable by The Metropolitan Government upon recommendation of the Director of NDOT and approval by resolution of the Metropolitan County Council if it is determined to be necessary to the public welfare and convenience. In the event the Metropolitan Government revokes this license as contemplated by this paragraph, licensee will not be entitled to any compensation of any kind. This license shall also be strictly subject to the right of way easement owned by The Metropolitan Government. I/We agree to maintain, construct and use the encroachment in such a way as will not interfere with the rights and duties of the Metropolitan Government

as owner of the right of way. Said interference shall be additional grounds for revocation of the license for encroachment. I/We agree to pay the cost of construction, maintenance, use, as well as relocations cost of said encroachment. Licensee's failure to complete construction of the contemplated encroachment within 36 months of the date of approval by the Metropolitan Council will cause this license to terminate automatically. In the event the encroachment contemplated by this license is substantially destroyed, this license shall terminate unless fully restored by licensee within 36 months from the date of such destruction. In the event this license is revoked or terminated for any reason, licensee shall restore all public property to the condition obtaining at the time the license became effective at licensee's sole cost and expense.

DATE: 6/18/26

[Signature]
(Owner of Property)
1 Titans Way
(Address of Property)
Nashville, TN 37213
(City and State)

STATE OF TENNESSEE)

COUNTY OF DAVIDSON)

Sworn to and subscribed before

Me this 18 day of JUNE, 2026

[Signature: Nicole Kesten]
(NOTARY PUBLIC)

My Commission Expires: 11/8/28



LEGEND

○ INDICATES BANNER ARM ON LIGHT POST

TOTAL COUNT

○ 28 BANNER ARMS - ALL POSTS

NOTE: REFER TO NEXT PAGE FOR BANNER ELEVATION

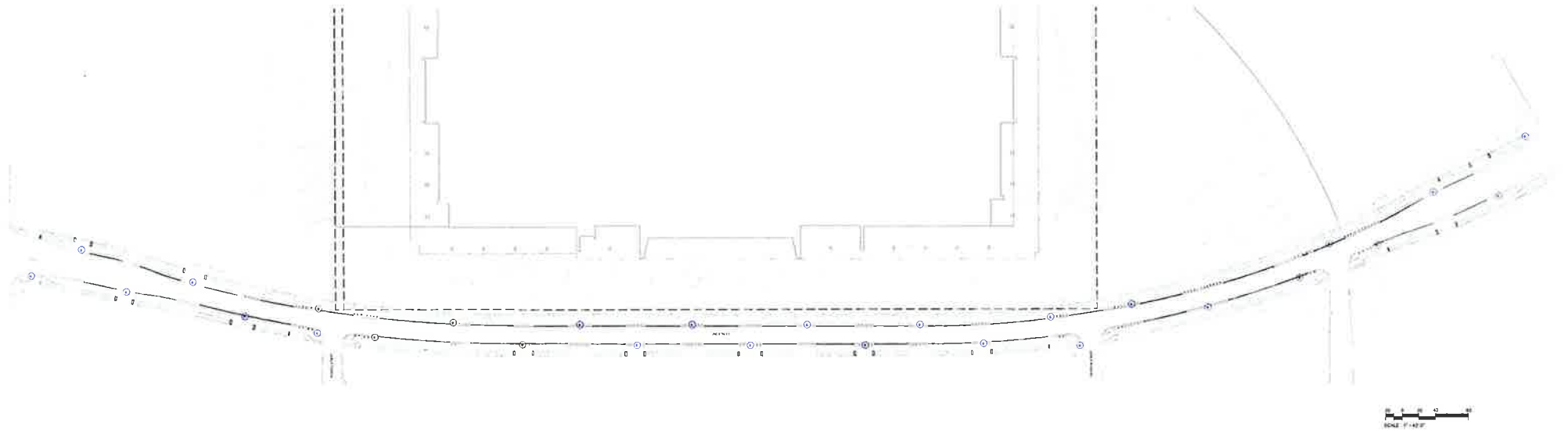

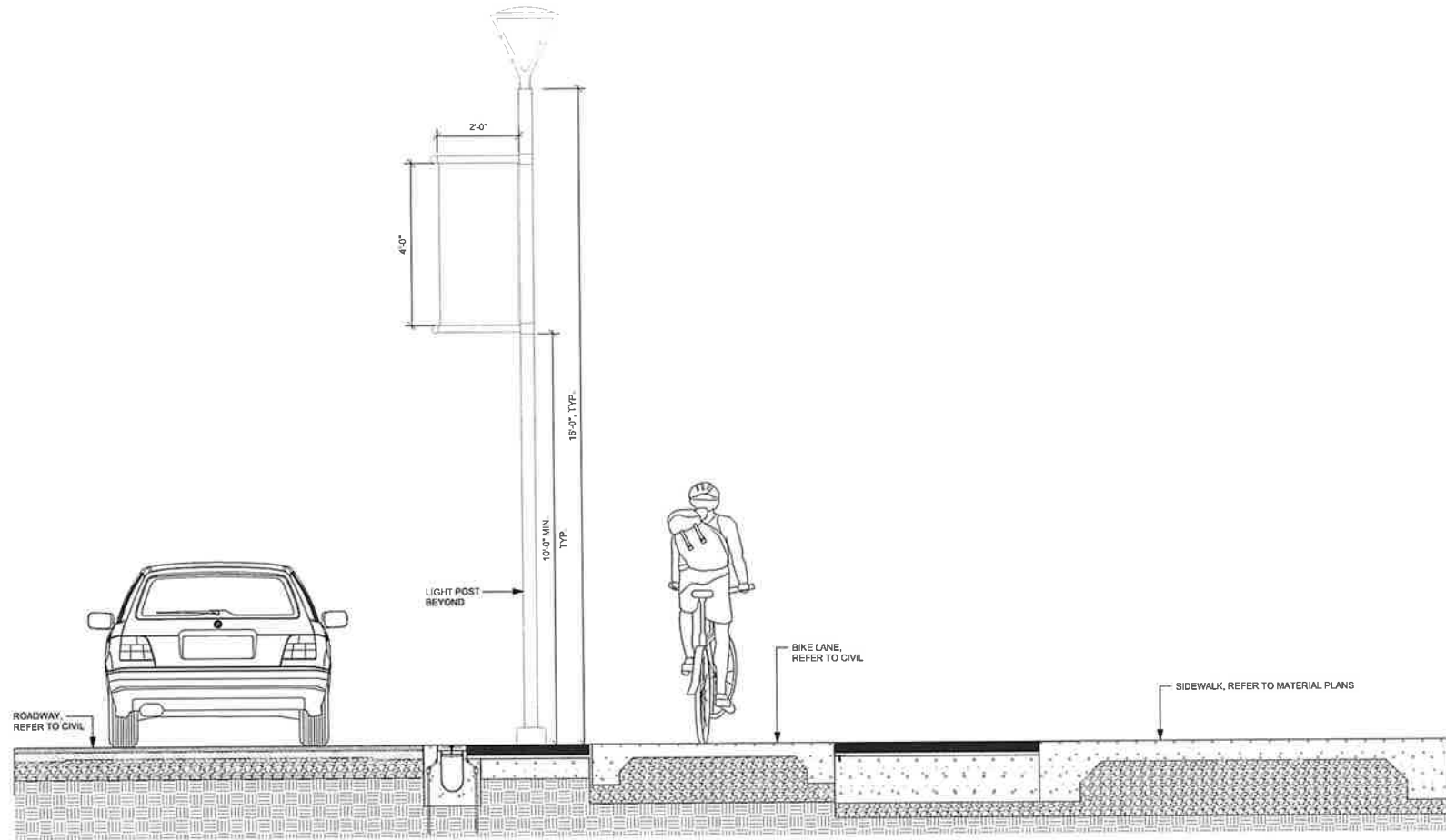

1 SECTION: LIGHT POST WITH BANNER ARMS
Scale: 3/4" = 1'-0"



Banner Arms

ARMS

DATE: 02-17-2026 LOCATION: _____
 TYPE: LPA- Banner PROJECT: South 2nd Street- Nissan Stadium Streetscape
 CATALOG #: AA-0024-4MTC-BA2X-BLT

SPECIFICATIONS

CONSTRUCTION

All cast aluminum parts shall low copper alloy A356. All extruded aluminum parts shall be alloy 6061-T6, 6063-T5 or equal.

FASTENERS

All fasteners shall be stainless steel. When tamper resistant fasteners are required, spanner HD (snake eye) style shall be provided (special tool required, available at additional cost), consult factory for availability.

FINISH

Finish shall be Beacote III polyester powdercoat electrostatically applied and thermocured. Poles shall be subjected to chemical pre-treatment prior to painting by immersion process.

OPTIONS

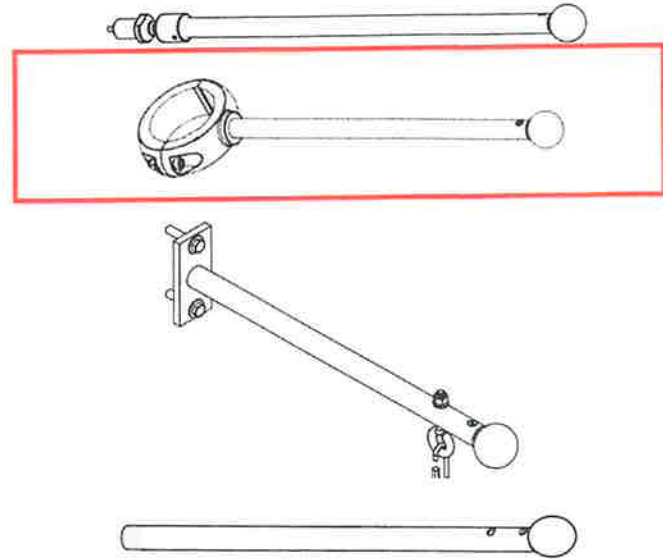
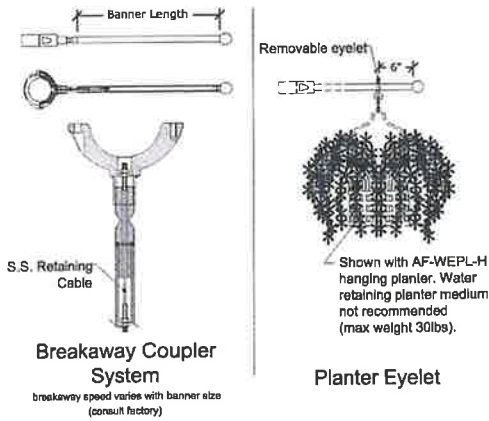

ORDERING GUIDE

Example: AA-0024-4MTC-BA-BKT

CATALOG # AA-0024-4MTC-BA2X-BLT

Series	Length	Mounting	Options	Finish
AA-00	18 18" 20 20" 22 22" 24 24" 30 30"	4MTC Mounting Collar for 4 inch shaft 5MTC Mounting Collar for 5 inch shaft 6MTC Mounting Collar for 6 inch shaft BO Bolted Connection TO Threaded Connection	BA Breakaway coupler system* PA Removable planter eyelet* 2X Two banner arms at 180°	BLT Black Matte Textured BLS Black Gloss Smooth DBT Dark Bronze Matte Textured DBS Dark Bronze Gloss Smooth GTT Graphite Matte Textured LGT Light Grey Gloss Textured LGS Light Grey Gloss Smooth PSS Platinum Silver Smooth WHT White Matte Textured WHS White Gloss Smooth VGT Verde Green Textured Color Option CC Custom Color

Notes

- * Consult factory
- * TO requires couplings to connect arm to pole - ordered separately



Banner Arms

ARMS

BANNER ARMS MOUNTING STYLES

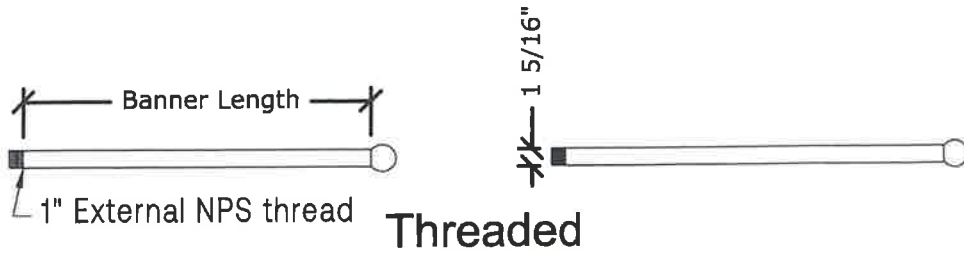
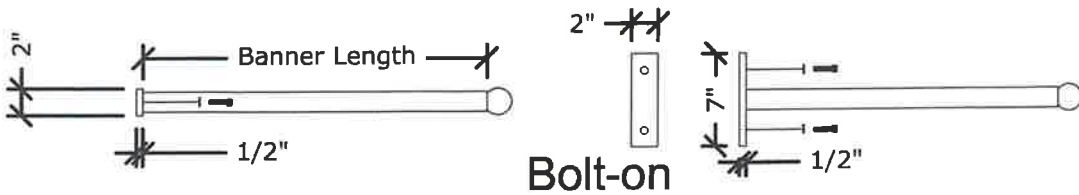
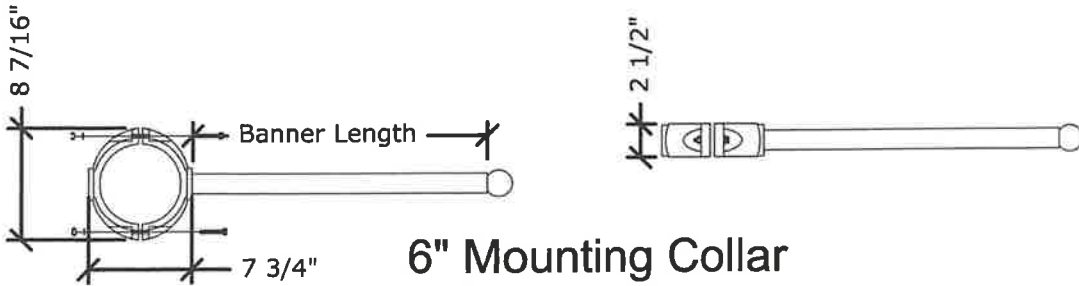
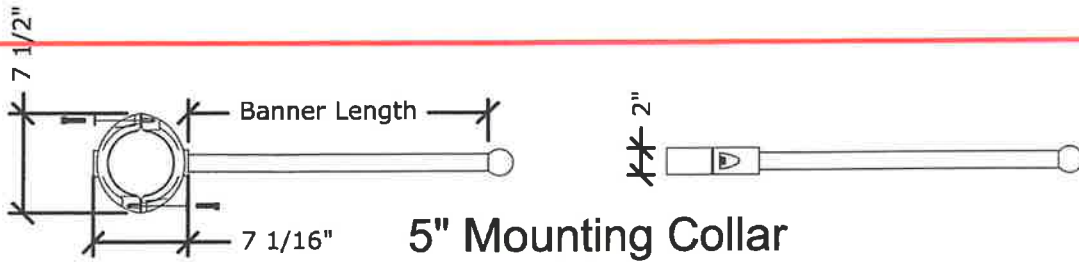
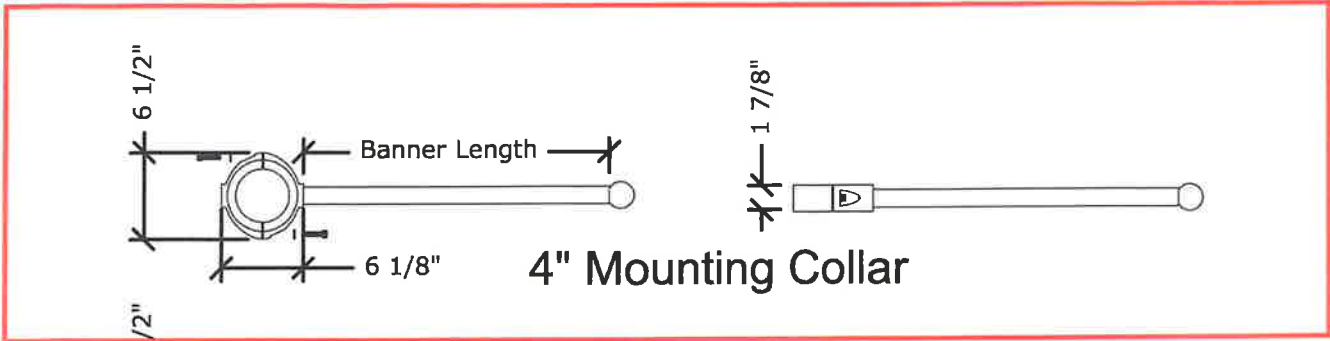

LEGEND

○ INDICATES BANNER ARM ON LIGHT POST

TOTAL COUNT

○ 28 BANNER ARMS - ALL POSTS

NOTE: REFER TO SHEET PAGE # ON BANNER ELEVATION

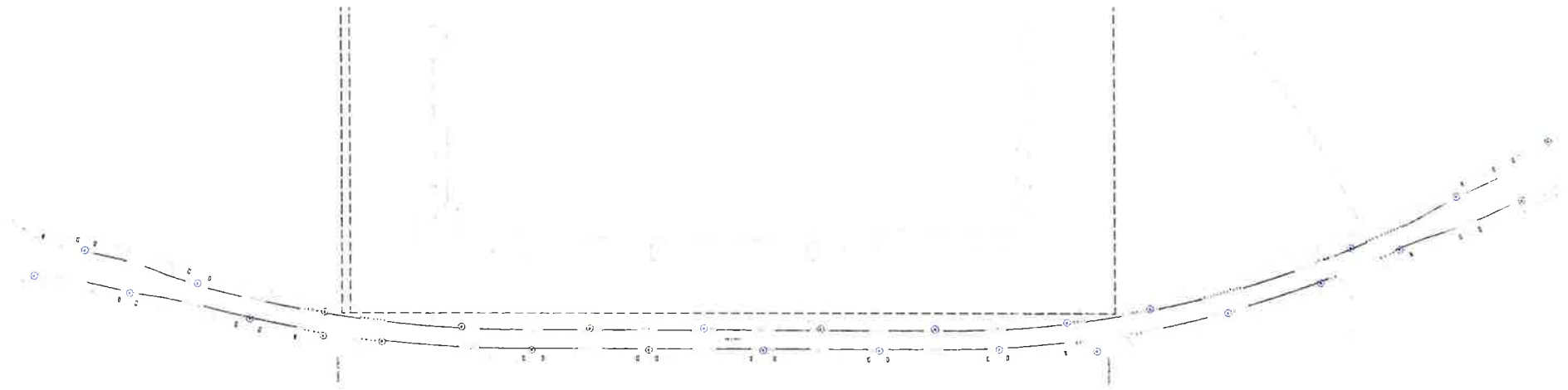

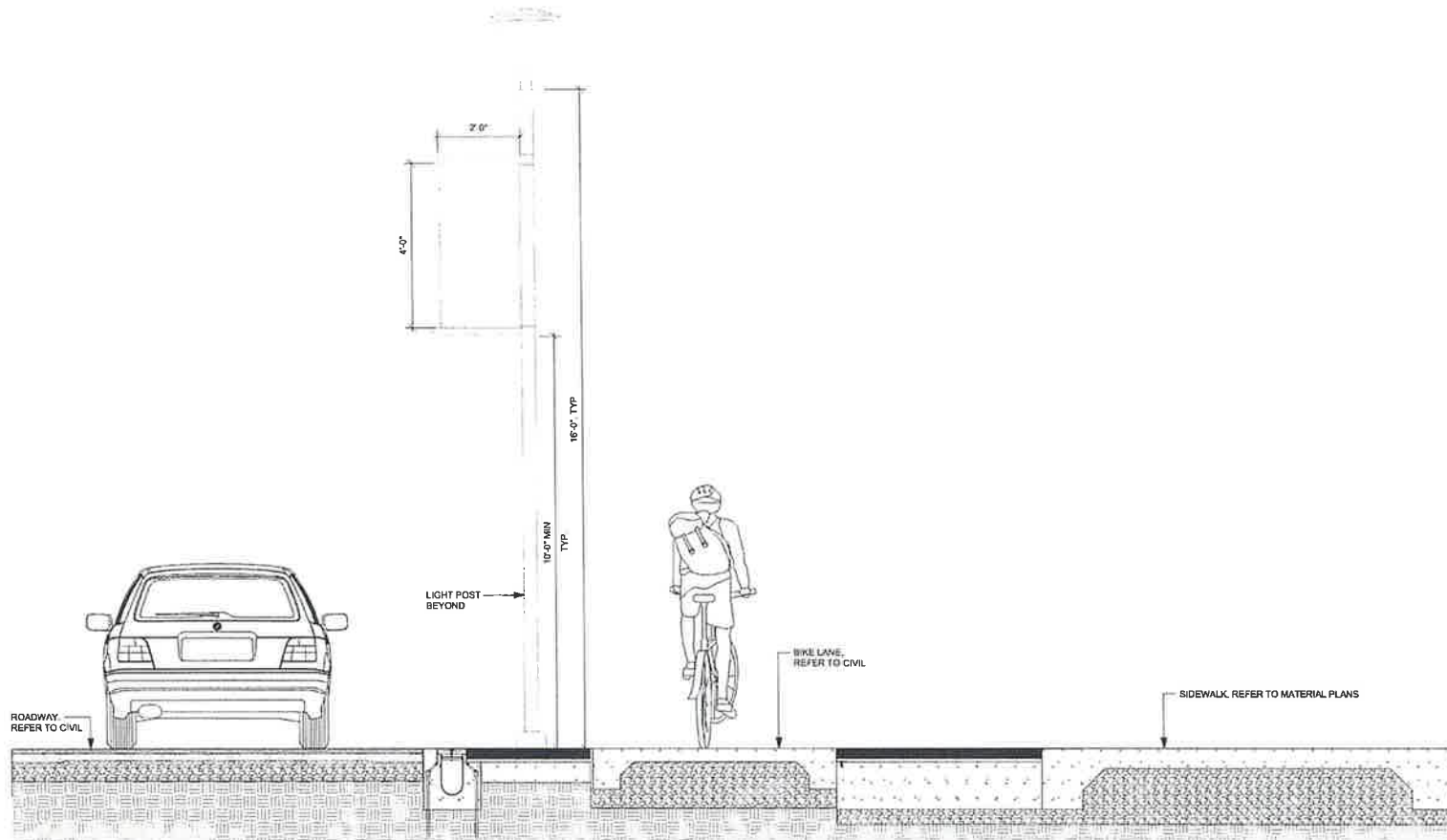

1 SECTION: LIGHT POST WITH BANNER ARMS
Scale: 3/4" = 1'-0"