

Proposal No. 2024M-001EN-001



SHVIMAI-01

NCRATZ

CERTIFICATE OF LIABILITY INSURANCE

DATE (MMDDYYYY)
6/25/2024

THIS CERTIFICATE IS ISSUED AS A MATTER OF INFORMATION ONLY AND CONFERS NO RIGHTS UPON THE CERTIFICATE HOLDER. THIS CERTIFICATE DOES NOT AFFIRMATIVELY OR NEGATIVELY AMEND, EXTEND OR ALTER THE COVERAGE AFFORDED BY THE POLICIES BELOW. THIS CERTIFICATE OF INSURANCE DOES NOT CONSTITUTE A CONTRACT BETWEEN THE ISSUING INSURER(S), AUTHORIZED REPRESENTATIVE OR PRODUCER, AND THE CERTIFICATE HOLDER.

IMPORTANT: If the certificate holder is an ADDITIONAL INSURED, the policy(ies) must have ADDITIONAL INSURED provisions or be endorsed. If SUBROGATION IS WAIVED, subject to the terms and conditions of the policy, certain policies may require an endorsement. A statement on this certificate does not confer rights to the certificate holder in lieu of such endorsement(s).

PRODUCER Onecap Services LLC 77 Spruce Street, Suite 203 Cedarhurst, NY 11516	CONTACT NAME: PHONE (A/C, No, Ext): (516) 545-0500 FAX (A/C, No): E-MAIL ADDRESS: info@onecapllc.com INSURER(S) AFFORDING COVERAGE NAIC # INSURER A : United Specialty Insurance Co 29599 INSURER B : Capitol Specialty Ins. Corp. 10328 INSURER C : INSURER D : INSURER E : INSURER F :
INSURED Shville Main GOZB, LLC 62 Beach Street New York, NY 10013	

COVERAGES CERTIFICATE NUMBER: REVISION NUMBER:

THIS IS TO CERTIFY THAT THE POLICIES OF INSURANCE LISTED BELOW HAVE BEEN ISSUED TO THE INSURED NAMED ABOVE FOR THE POLICY PERIOD INDICATED. NOTWITHSTANDING ANY REQUIREMENT, TERM OR CONDITION OF ANY CONTRACT OR OTHER DOCUMENT WITH RESPECT TO WHICH THIS CERTIFICATE MAY BE ISSUED OR MAY PERTAIN, THE INSURANCE AFFORDED BY THE POLICIES DESCRIBED HEREIN IS SUBJECT TO ALL THE TERMS, EXCLUSIONS AND CONDITIONS OF SUCH POLICIES. LIMITS SHOWN MAY HAVE BEEN REDUCED BY PAID CLAIMS.

INSR LTR	TYPE OF INSURANCE	ADDL INSD	SUBR WVD	POLICY NUMBER	POLICY EFF (MMDDYYYY)	POLICY EXP (MMDDYYYY)	LIMITS
A	<input checked="" type="checkbox"/> COMMERCIAL GENERAL LIABILITY	<input checked="" type="checkbox"/>		FXZ000529/2400	3/10/2024	3/10/2025	EACH OCCURRENCE \$ 1,000,000
	<input type="checkbox"/> CLAIMS-MADE <input checked="" type="checkbox"/> OCCUR						DAMAGE TO RENTED PREMISES (Ea occurrence) \$ 50,000
	<input type="checkbox"/>						MED EXP (Any one person) \$
	<input type="checkbox"/>						PERSONAL & ADV INJURY \$ 1,000,000
GEN'L AGGREGATE LIMIT APPLIES PER: <input type="checkbox"/> POLICY <input type="checkbox"/> PRO-JECT <input type="checkbox"/> LOC OTHER:							GENERAL AGGREGATE \$ 2,000,000
AUTOMOBILE LIABILITY							PRODUCTS - COMPROP AGG \$ 2,000,000
ANY AUTO OWNED AUTOS ONLY <input type="checkbox"/> SCHEDULED AUTOS HIRED AUTOS ONLY <input type="checkbox"/> NON-OWNED AUTOS ONLY							ASSAULT BATTERY \$ 200,000
							COMBINED SINGLE LIMIT (Ea accident) \$
							BODILY INJURY (Per person) \$
							BODILY INJURY (Per accident) \$
							PROPERTY DAMAGE (Per accident) \$
							\$
B	<input checked="" type="checkbox"/> UMBRELLA LIAB <input checked="" type="checkbox"/> OCCUR			XS23022343-01	3/10/2024	3/10/2025	EACH OCCURRENCE \$ 5,000,000
	<input type="checkbox"/> EXCESS LIAB <input type="checkbox"/> CLAIMS-MADE						AGGREGATE \$ 5,000,000
DED <input checked="" type="checkbox"/> RETENTION \$ 0							\$
WORKERS COMPENSATION AND EMPLOYERS' LIABILITY Y/N N/A							PER STATUTE OTH-ER
ANY PROPRIETOR/PARTNER/EXECUTIVE OFFICER/MEMBER EXCLUDED? (Mandatory in NY) If yes, describe under DESCRIPTION OF OPERATIONS below							E.L. EACH ACCIDENT \$
							E.L. DISEASE - EA EMPLOYEE \$
							E.L. DISEASE - POLICY LIMIT \$

DESCRIPTION OF OPERATIONS / LOCATIONS / VEHICLES (ACORD 101, Additional Remarks Schedule, may be attached if more space is required)
 Re: Sign for Molly Green 518 Main Street Nashville, TN 37206
 The Metropolitan Government of Nashville & Davidson County, Metro Legal and claims c/o Insurance and Safety Division is included as additional insured as requested by written contact. A 30 day notice of cancellation applies.

CERTIFICATE HOLDER The Metropolitan Government of Nashville & Davidson County Metro Legal and Claims 222 Third Ave N. Ste. 501 Nashville, TN 37201	CANCELLATION SHOULD ANY OF THE ABOVE DESCRIBED POLICIES BE CANCELLED BEFORE THE EXPIRATION DATE THEREOF, NOTICE WILL BE DELIVERED IN ACCORDANCE WITH THE POLICY PROVISIONS. AUTHORIZED REPRESENTATIVE
---	--

ACORD 25 (2016/03)

© 1988-2015 ACORD CORPORATION. All rights reserved.

The ACORD name and logo are registered marks of ACORD

{N0630224.1}

LICENSE AGREEMENT FOR PRIVATE ENCROACHMENTS
INTO THE PUBLIC RIGHT OF WAY

Victor Zucy, On behalf of Shullie main GORBLE C
I/We, _____, in consideration of the Resolution No. _____, to

construct, maintain, install and/or operate an encroachment into, onto, over, or under the public right of way located at in Nashville, Davidson County, Tennessee, do hereby, for myself, my agents, customers, and assigns, waive and release and hold harmless The Metropolitan Government of Nashville and Davidson County, its agents, employees, and assigns from any and all claims, rights, or demands for damages that may arise from my/our use, construction and/or maintenance of the encroachment, to wit: (SEE ATTACHED DESCRIPTION OF ENCROACHMENT). I/We hereby certify to the Metropolitan Government of Nashville and Davidson County that I/We have executed a bond or liability insurance policy in such amount as agreed upon by the Director of NDOT and the Metropolitan Attorney, and in the form approved by the Metropolitan Attorney (per Metropolitan Code Section 38-1-1), which operates to indemnify and save The Metropolitan Government of Nashville and Davidson County harmless from all claims or demands that may result to persons or property by reason of the construction, operations or maintenance of the encroachment. I/We further agree that my/our obligations hereunder may not be assigned except upon approval of the Director of NDOT and the Metropolitan Attorney. I/We further acknowledge that any action that results in a failure to maintain said bond or liability insurance for the protection of The Metropolitan Government of Nashville and Davidson County shall operate to the granting of a lien to The Metropolitan Government of Nashville and Davidson County in the amount of the last effective bond/insurance policy. Said insurance or bond may not be cancelable or expirable except on 30 days' notice to the Director of NDOT.

I/We further recognize that the license granted hereby is revocable by The Metropolitan Government upon recommendation of the Director of NDOT and approval by resolution of the Metropolitan County Council if it is determined to be necessary to the public welfare and convenience. In the event the Metropolitan Government revokes this license as contemplated by this paragraph, licensee will not be entitled to any compensation of any kind. This license shall also be strictly subject to the right of way easement owned by The Metropolitan Government. I/We agree to maintain, construct and use the encroachment in such a way as will not interfere with the rights and duties of the Metropolitan Government

as owner of the right of way. Said interference shall be additional grounds for revocation of the license for encroachment. I/We agree to pay the cost of construction, maintenance, use, as well as relocations cost of said encroachment. Licensee's failure to complete construction of the contemplated encroachment within 36 months of the date of approval by the Metropolitan Council will cause this license to terminate automatically. In the event the encroachment contemplated by this license is substantially destroyed, this license shall terminate unless fully restored by licensee within 36 months from the date of such destruction. In the event this license is revoked or terminated for any reason, licensee shall restore all public property to the condition obtaining at the time the license became effective at licensee's sole cost and expense.

DATE: JUNE 27 2024
Shuttleman 602B LLC
 (Owner of Property)
 By Victor Ezeje member
18 McFerrin, Nashville
 (Address of Property)
Nashville, TN
 (City and State)

New York
 STATE OF ~~TENNESSEE~~
New York
 COUNTY OF ~~DAVIDSON~~

Sworn to and subscribed before
 Me this 27th day of June, 2024

[Signature]
 (NOTARY PUBLIC)

My Commission Expires: _____
ROBIN WALTON
 Notary Public, State of New York
 Reg. No. Registration No: 01WA4855069
 Qualified in Queens County
 Commission Expires March 24, 2026

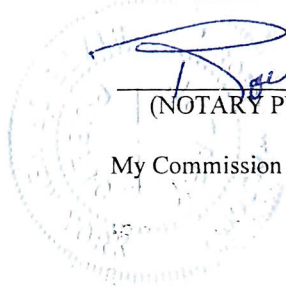



630 MURFREESBORO PIKE
NASHVILLE, TN 37210

615_255_3463
615_255_3518 FAX

JOSLINSIGN.COM

MOLLY GREEN

918 MAIN ST
NASHVILLE, TN 37206

DRW#_ 230758-K40

QUOTE#_ 108459

WK_ORD#_ 393904

DESIGNER_ J.MORTON

PROJ_MGR_ K.CLARK

DATE_ 12.12.23

COLORS & FINISHES:

■ SATIN BLACK

NEW RACEWAY

SCALE: 1/2"=1'0"

- FABRICATE RACEWAY FOR EXISTING CHANNEL LETTER SET
- RACEWAY PAINTED SATIN BLACK
- INSTALL ENTIRE SIGN

SECTION DETAILS/MOUNTING
PAGE 2

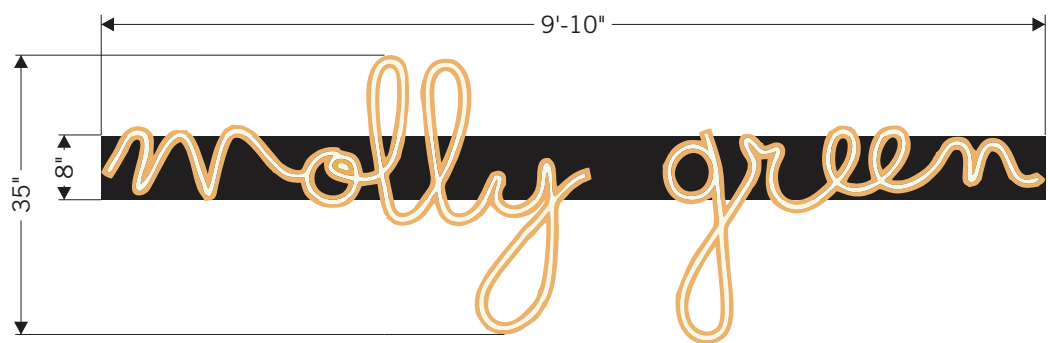

CUSTOMER SIGNATURE

COPYRIGHT © 2023

ALL PRINT AND ELECTRONIC ART REMAINS THE SOLE COPYRIGHTED PROPERTY OF JOSLIN SIGNS, INC. AND ARE NOT TO BE DISTRIBUTED, COPIED, E-MAILED OR TRANSFERRED IN ANY WAY WITHOUT PRIOR WRITTEN RELEASE FROM JOSLIN SIGNS, INC.



OPEN FACE NEON CHANNEL LETTERS ON RACEWAY MOUNTED TO BRICK

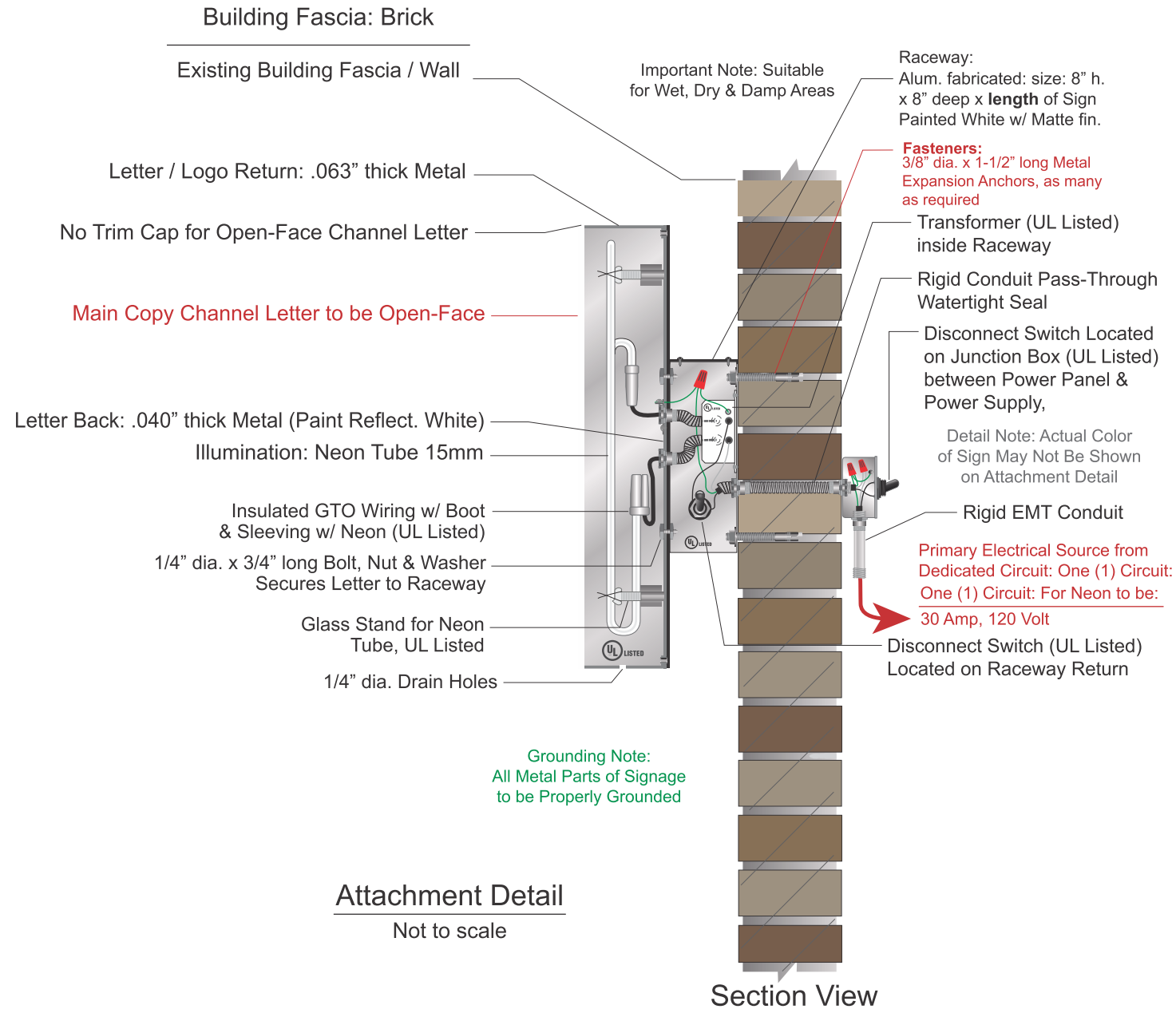

ELECTRICAL NOTES

ELECTRICAL IN J. BOX INSIDE CAB CONNECTED TO PRIMARY LEADS:

POWER-POWER
NEUTRAL-NEUTRAL
GROUND-GROUND

THIS SIGN IS INTENDED TO BE INSTALLED IN ACCORDANCE WITH THE REQUIREMENTS OF ARTICLE 600 OF THE NATIONAL ELECTRICAL CODE AND/OR OTHER APPLICABLE LOCAL CODES. THIS INCLUDES PROPER GROUNDING AND BONDING OF THE SIGN.

SUITABLE FOR WET LOCATIONS

NOT TO SCALE



630 MURFREESBORO PIKE
NASHVILLE, TN 37210

615_255_3463
615_255_3518 FAX

JOSLINSIGN.COM

MOLLY GREEN

918 MAIN ST
NASHVILLE, TN 37206

DRW#_ 230758-K40

QUOTE#_ 108459

WK_ORD#_ 393904

DESIGNER_ J.MORTON

PROJ_MGR_ K.CLARK

DATE_ 12.12.23

COLORS & FINISHES:

CUSTOMER SIGNATURE

COPYRIGHT © 2023

ALL PRINT AND ELECTRONIC ART REMAINS THE SOLE COPYRIGHTED PROPERTY OF JOSLIN SIGNS, INC. AND ARE NOT TO BE DISTRIBUTED, COPIED, E-MAILED OR TRANSFERRED IN ANY WAY WITHOUT PRIOR WRITTEN RELEASE FROM JOSLIN SIGNS, INC.

SHEET 2 OF 4

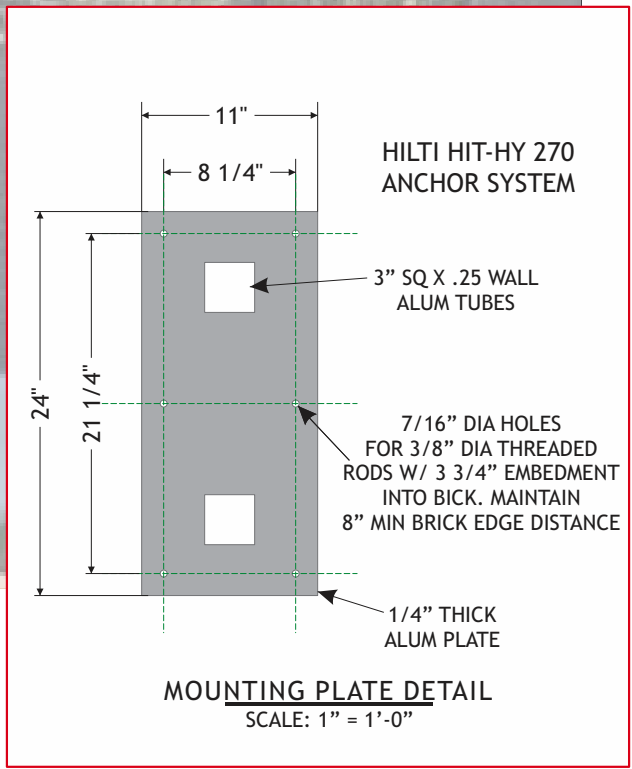
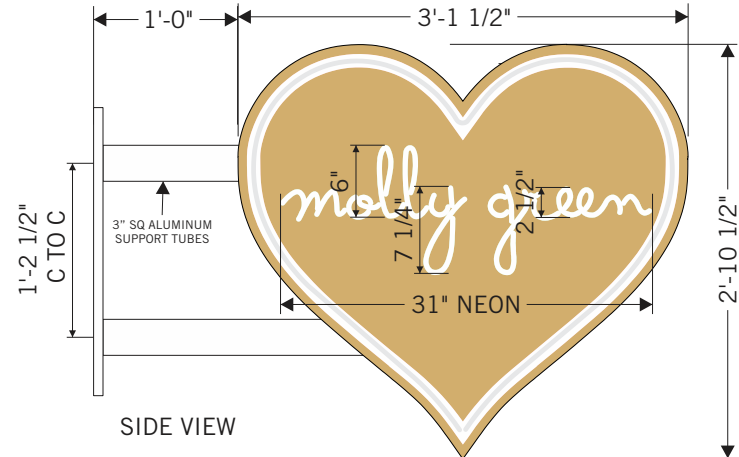
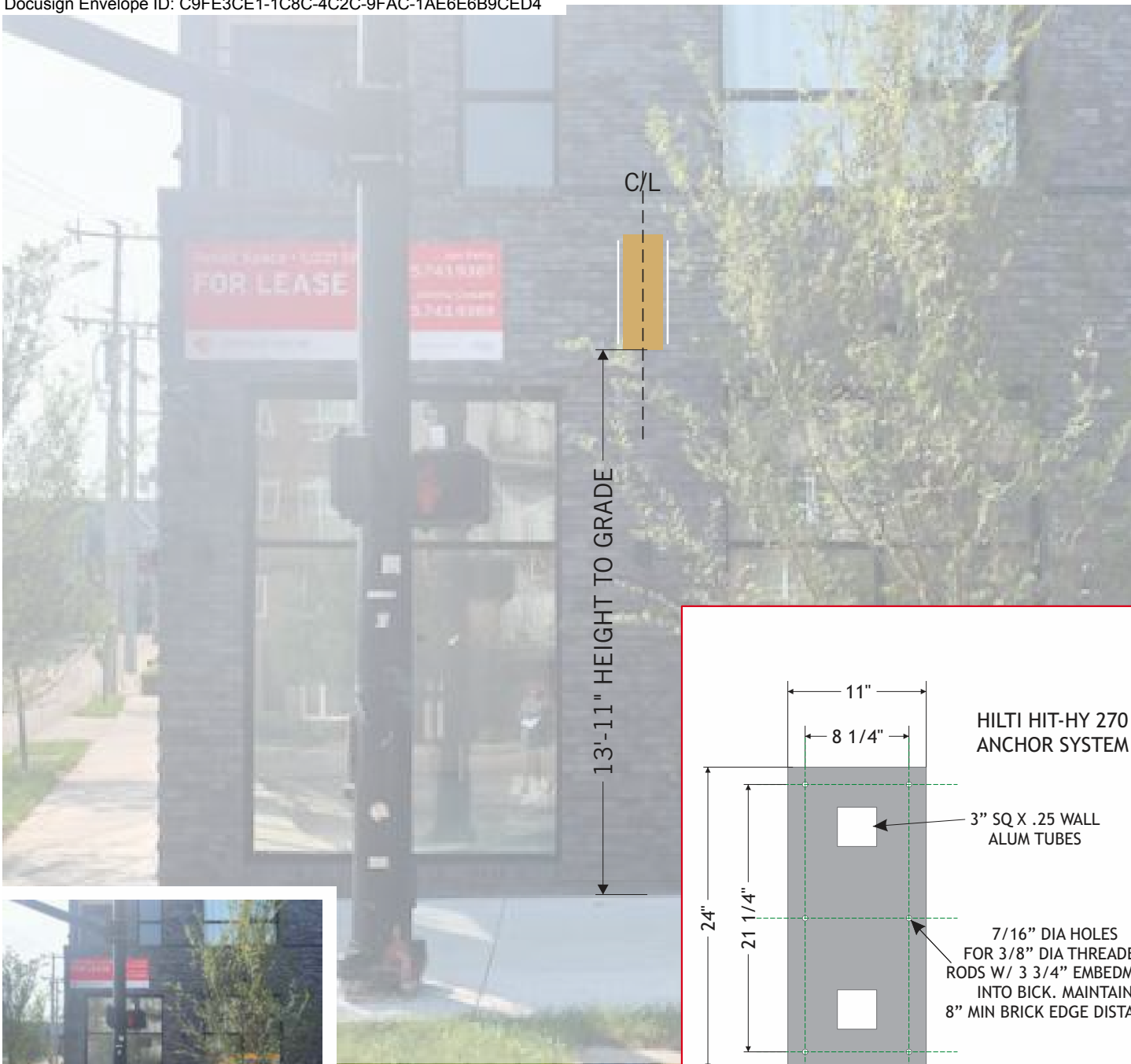

RE-PAINT EXISTING NEW NEON COPY

SCALE: 3/4" = 1'0"

- RE-PAINT EXISTING SIGN GOLD TO MATCH EXISTING CHANNEL LETTERS.
- WHITE PAINTED HEART OUTLINE & COPY ON FACE.
- WHITE MOUNTING POLES AND PLATES.
- RE-INSTALL EXISTING WHITE HEART NEON
- MAKE NEW WHITE NEON COPY TO MATCH HEART NEON (10MM E-300 WARM WHITE)

USE PAINT MASK AND NEON PATTERN FROM ORIGINAL SIGN PRODUCTION 2019 - DWG#190652-L30

GOLD PAINT COLOR TO MATCH EXISTING CHANNEL LETTER RETURNS.

SECTION DETAILS/MOUNTING PAGE 4



630 MURFREESBORO PIKE
NASHVILLE, TN 37210

615_255_3463
615_255_3518 FAX

JOSLINSIGN.COM

MOLLY GREEN

918 MAIN ST
NASHVILLE, TN 37206

DRW#_ 230758-K40

QUOTE#_ 108459

WK_ORD#_ 393904

DESIGNER_ J.MORTON

PROJ_MGR_ K.CLARK

DATE_ 12.12.23

COLORS & FINISHES:

- SCAN OF EXISTING CHANNEL LETTERS- PAINT TO MATCH FLNA95352 SATIN GLOSS
- WHITE GRAPHICS ON FACE MOUNTING POLES & PLATES SATIN FINISH
- 10MM E-300 WARM WHITE NEON

CUSTOMER SIGNATURE

COPYRIGHT © 2023
ALL PRINT AND ELECTRONIC ART REMAINS THE SOLE COPYRIGHTED PROPERTY OF JOSLIN SIGNS, INC. AND ARE NOT TO BE DISTRIBUTED, COPIED, E-MAILED OR TRANSFERRED IN ANY WAY WITHOUT PRIOR WRITTEN RELEASE FROM JOSLIN SIGNS, INC.



D/F ILLUMINATED BLADE SIGN MOUNTED TO BRICK



630 MURFREESBORO PIKE
NASHVILLE, TN 37210

615_255_3463
615_255_3518 FAX

JOSLINSIGN.COM

MOLLY GREEN

918 MAIN ST
NASHVILLE, TN 37206

DRW#_ 230758-K40

QUOTE#_ 108459

WK_ORD#_ 393904

DESIGNER_ J.MORTON

PROJ_MGR_ K.CLARK

DATE_ 12.12.23

COLORS & FINISHES:

CUSTOMER SIGNATURE

COPYRIGHT © 2023

ALL PRINT AND ELECTRONIC ART REMAINS THE SOLE COPYRIGHTED PROPERTY OF JOSLIN SIGNS, INC. AND ARE NOT TO BE DISTRIBUTED, COPIED, E-MAILED OR TRANSFERRED IN ANY WAY WITHOUT PRIOR WRITTEN RELEASE FROM JOSLIN SIGNS, INC.

SHEET 4 OF 4

APPROVED
ELECTRIC SIGN SECTION
UL LISTED

ALL ELECTRICAL COMPONENTS
UL LISTED

This product is Classified by UL as to the properties of product tested (only)

NEC, State & Local Codes:
Codes May Change from Year to Year. Consult with the NEC Code Books for Current Information

Important Note:
Suitable for Wet, Dry & Damp Areas

Building Fascia: Brick

Existing Building Fascia / Wall

Returns: to be .090" thick
Painted

(Double-Sided Blade, Illuminated)

Blade Sign Face: .090" thick Metal
with Illumination: Neon Tube 15mm

Fabricator Note:
Insulated Wiring to Disconnect
Switch, and Power Supply
is Suggested

Electrical Notes:

- > All Materials, Fasteners to Meet Code 3004.4
- > All Electrical Components Must Be UL Listed
- > Sign(s) Should be Grounded, NEC 600.7
- > Sign(s) are Made in Accordance with NEC 600
- > One (1) 20 Amp Circuit Dedicated to Each Sign
- > One (1) Disconnect Switch to be Visible Per Circuit

(Blade Sign Flush Mounted
to Bldg. Fascia / Wall)

Attachment Detail

Not to scale

Installation Note:
All Signage & Component
to be Properly Grounded

Viewer Note:
Actual Sign Color May Not Be

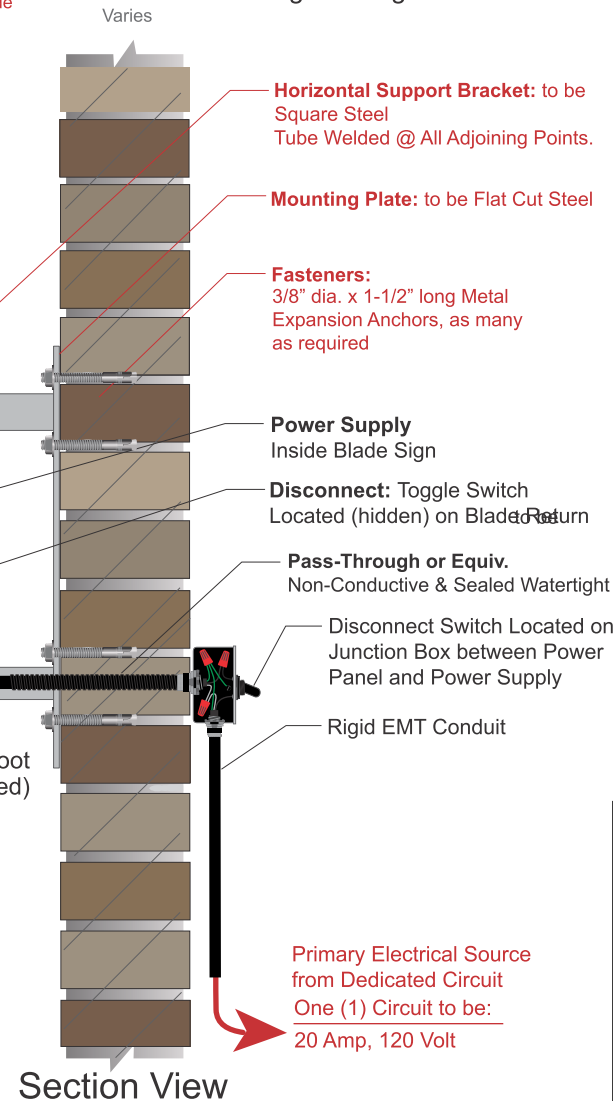

Section View

ELECTRICAL NOTES

ELECTRICAL IN J. BOX
INSIDE CAB CONNECTED
TO PRIMARY LEADS:
POWER-POWER
NEUTRAL-NEUTRAL
GROUND-GROUND

THIS SIGN IS INTENDED TO BE INSTALLED IN ACCORDANCE WITH THE REQUIREMENTS OF ARTICLE 600 OF THE NATIONAL ELECTRICAL CODE AND/OR OTHER APPLICABLE LOCAL CODES. THIS INCLUDES PROPER GROUNDING AND BONDING OF THE SIGN.

SUITABLE FOR WET LOCATIONS

NOT TO SCALE