

Client#: 2308241

22MARKEMAN

ACORDTM

CERTIFICATE OF LIABILITY INSURANCE

DATE (MM/DD/YYYY)

7/19/2023

THIS CERTIFICATE IS ISSUED AS A MATTER OF INFORMATION ONLY AND CONFERS NO RIGHTS UPON THE CERTIFICATE HOLDER. THIS CERTIFICATE DOES NOT AFFIRMATIVELY OR NEGATIVELY AMEND, EXTEND OR ALTER THE COVERAGE AFFORDED BY THE POLICIES BELOW. THIS CERTIFICATE OF INSURANCE DOES NOT CONSTITUTE A CONTRACT BETWEEN THE ISSUING INSURER(S), AUTHORIZED REPRESENTATIVE OR PRODUCER, AND THE CERTIFICATE HOLDER.

IMPORTANT: If the certificate holder is an ADDITIONAL INSURED, the policy(ies) must have ADDITIONAL INSURED provisions or be endorsed. If SUBROGATION IS WAIVED, subject to the terms and conditions of the policy, certain policies may require an endorsement. A statement on this certificate does not confer any rights to the certificate holder in lieu of such endorsement(s).

PRODUCER McGriff Insurance Services LLC 3322 West End Ave., Suite 300 Nashville, TN 37203	CONTACT NAME: Regina Harris
	PHONE (A/C, No, Ext): 615-346-0330 FAX (A/C, No): 8777677417 E-MAIL ADDRESS: reharris@mcgriff.com
INSURED Nashville Urban Venture LLC 124 12th Ave. S., Suite 600 Nashville, TN 37203	INSURER(S) AFFORDING COVERAGE NAIC #
	INSURER A : Travelers Indemnity Company 25658
	INSURER B : Travelers Property Casualty Co of Amer 25674
	INSURER C :
	INSURER D :
	INSURER E :

COVERAGES CERTIFICATE NUMBER: REVISION NUMBER:

THIS IS TO CERTIFY THAT THE POLICIES OF INSURANCE LISTED BELOW HAVE BEEN ISSUED TO THE INSURED NAMED ABOVE FOR THE POLICY PERIOD INDICATED. NOTWITHSTANDING ANY REQUIREMENT, TERM OR CONDITION OF ANY CONTRACT OR OTHER DOCUMENT WITH RESPECT TO WHICH THIS CERTIFICATE MAY BE ISSUED OR MAY PERTAIN, THE INSURANCE AFFORDED BY THE POLICIES DESCRIBED HEREIN IS SUBJECT TO ALL THE TERMS, EXCLUSIONS AND CONDITIONS OF SUCH POLICIES. LIMITS SHOWN MAY HAVE BEEN REDUCED BY PAID CLAIMS.

INSR LTR	TYPE OF INSURANCE	ADDL INSR	SUBR WVD	POLICY NUMBER	POLICY EFF (MM/DD/YYYY)	POLICY EXP (MM/DD/YYYY)	LIMITS
A	<input checked="" type="checkbox"/> COMMERCIAL GENERAL LIABILITY <input type="checkbox"/> CLAIMS-MADE <input checked="" type="checkbox"/> OCCUR GEN'L AGGREGATE LIMIT APPLIES PER: <input type="checkbox"/> POLICY <input type="checkbox"/> PRO-JECT <input type="checkbox"/> LOC OTHER:	X		Y630962J4170IND23	07/01/2023	07/01/2024	EACH OCCURRENCE \$ 1,000,000 DAMAGE TO RENTED PREMISES (Ea occurrence) \$ 300,000 MED EXP (Any one person) \$ 5,000 PERSONAL & ADV INJURY \$ 1,000,000 GENERAL AGGREGATE \$ 2,000,000 PRODUCTS - COMP/OP AGG \$ 2,000,000 \$
A	<input checked="" type="checkbox"/> AUTOMOBILE LIABILITY <input checked="" type="checkbox"/> ANY AUTO OWNED AUTOS ONLY <input type="checkbox"/> SCHEDULED AUTOS <input checked="" type="checkbox"/> HIRED AUTOS ONLY <input checked="" type="checkbox"/> NON-OWNED AUTOS ONLY			BA9T9265702314G	07/01/2023	07/01/2024	COMBINED SINGLE LIMIT (Ea accident) \$ 1,000,000 BODILY INJURY (Per person) \$ BODILY INJURY (Per accident) \$ PROPERTY DAMAGE (Per accident) \$ \$
B	<input checked="" type="checkbox"/> UMBRELLA LIAB <input checked="" type="checkbox"/> OCCUR <input type="checkbox"/> EXCESS LIAB <input type="checkbox"/> CLAIMS-MADE <input type="checkbox"/> DED <input checked="" type="checkbox"/> RETENTION \$0			CUP9T9272902314	07/01/2023	07/01/2024	EACH OCCURRENCE \$ 25,000,000 AGGREGATE \$ 25,000,000 \$
	WORKERS COMPENSATION AND EMPLOYERS' LIABILITY ANY PROPRIETOR/PARTNER/EXECUTIVE OFFICER/MEMBER EXCLUDED? (Mandatory In NH) <input type="checkbox"/> Y/N If yes, describe under DESCRIPTION OF OPERATIONS below		N/A				PER STATUTE OTH-ER E.L. EACH ACCIDENT \$ E.L. DISEASE - EA EMPLOYEE \$ E.L. DISEASE - POLICY LIMIT \$

DESCRIPTION OF OPERATIONS / LOCATIONS / VEHICLES (ACORD 101, Additional Remarks Schedule, may be attached if more space is required)
Loc# 1 - 609 Overton Street; Nashville, TN
The Metropolitan Government of Nashville and Davidson County is included as an Additional Insured as respects to General Liability.

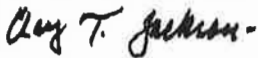
CERTIFICATE HOLDER Metropolitan Government of Nashville and Davidson County Metro Legal & Claims c/o Insurance & Safety Division 222 3rd Ave. N., Ste. #501 Nashville, TN 37201	CANCELLATION SHOULD ANY OF THE ABOVE DESCRIBED POLICIES BE CANCELLED BEFORE THE EXPIRATION DATE THEREOF, NOTICE WILL BE DELIVERED IN ACCORDANCE WITH THE POLICY PROVISIONS. AUTHORIZED REPRESENTATIVE 
---	--

LICENSE AGREEMENT FOR PRIVATE ENCROACHMENTS
INTO THE PUBLIC RIGHT OF WAY

I/We, Nashville Urban Venture, LLC, in consideration of the Resolution No. _____, to construct, maintain, install and/or operate an encroachment into, onto, over, or under the public right of way located at in Nashville, Davidson County, Tennessee, do hereby, for myself, my agents, customers, and assigns, waive and release and hold harmless The Metropolitan Government of Nashville and Davidson County, its agents, employees, and assigns from any and all claims, rights, or demands for damages that may arise from my/our use, construction and/or maintenance of the encroachment, to wit: (SEE ATTACHED DESCRIPTION OF ENCROACHMENT). I/We hereby certify to the Metropolitan Government of Nashville and Davidson County that I/We have executed a bond or liability insurance policy in such amount as agreed upon by the Director of Public Works and the Metropolitan Attorney, and in the form approved by the Metropolitan Attorney (per Metropolitan Code Section 38-1-1), which operates to indemnify and save The Metropolitan Government of Nashville and Davidson County harmless from all claims or demands that may result to persons or property by reason of the construction, operations or maintenance of the encroachment. I/We further agree that my/our obligations hereunder may not be assigned except upon approval of the Director of Public Works and the Metropolitan Attorney. I/We further acknowledge that any action that results in a failure to maintain said bond or liability insurance for the protection of The Metropolitan Government of Nashville and Davidson County shall operate to the granting of a lien to The Metropolitan Government of Nashville and Davidson County in the amount of the last effective bond/insurance policy. Said insurance or bond may not be cancelable or expirable except on 30 days notice to the Director of Public Works.

I/We further recognize that the license granted hereby is revocable by The Metropolitan Government upon recommendation of the Director of Public Works and approval by resolution of the Metropolitan County Council if it is determined to be necessary to the public welfare and convenience. In the event the Metropolitan Government revokes this license as contemplated by this paragraph, licensee will not be entitled to any compensation of any kind. This license shall also be strictly subject to the right of way easement owned by The Metropolitan Government. I/We agree to maintain, construct and use the encroachment in such a way as will not interfere with the rights and duties of the Metropolitan Government

as owner of the right of way. Said interference shall be additional grounds for revocation of the license for encroachment. I/We agree to pay the cost of construction, maintenance, use, as well as relocations cost of said encroachment. Licensee's failure to complete construction of the contemplated encroachment within 36 months of the date of approval by the Metropolitan Council will cause this license to terminate automatically. In the event the encroachment contemplated by this license is substantially destroyed, this license shall terminate unless fully restored by licensee within 36 months from the date of such destruction. In the event this license is revoked or terminated for any reason, licensee shall restore all public property to the condition obtaining at the time the license became effective at licensee's sole cost and expense.

DATE: 7/20/23

Nashville Urban Venture, LLC
2 Melvin S Phelps, CFO

(Owner of Property)

607 Overton St.
(Address of Property)

Nashville, TN 37203
(City and State)

STATE OF TENNESSEE)

COUNTY OF DAVIDSON)

Sworn to and subscribed before

Me this 20 day of July, 2023

Valerie Campbell
(NOTARY PUBLIC)

My Commission Expires: 5-3-2027



IBERIAN MG
NASHVILLE, TN.

12/22/22

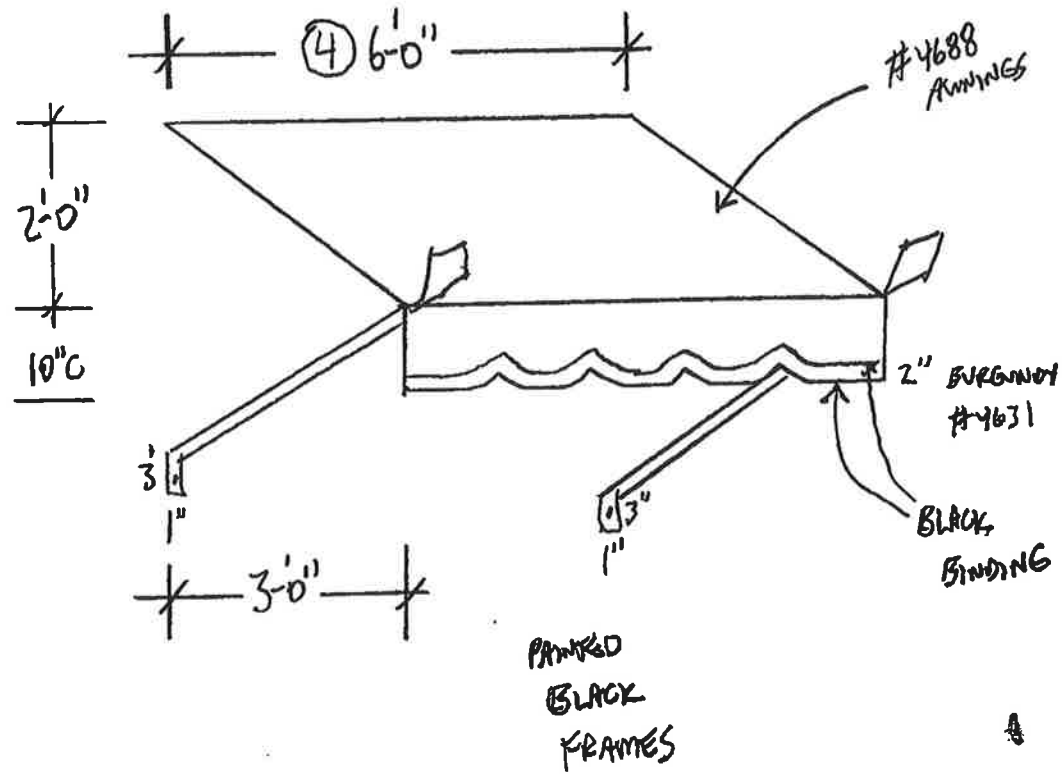

NASHVILLE TENT & AWNING CO.
1301 HERMAN ST.
NASHVILLE, TN 37208
(615) 329-3701



NTACO, LLC
dba Nashville Tent & Awning
Binks Lewis

OFFICE: 615/329-3701 FAX: 615/329-9117 DIRECT: 615/425-3156
1727 Elm Hill Pike, NASHVILLE, TN 37210
E-mail: blewis@ntaco.com

BSW501 | FATHOM

WET LOCATION FOR OUTDOOR APPLICATIONS



1-3/8" O.D. arm mount LED luminaire for outdoor locations and remote driver operation

Project: _____ Type: _____

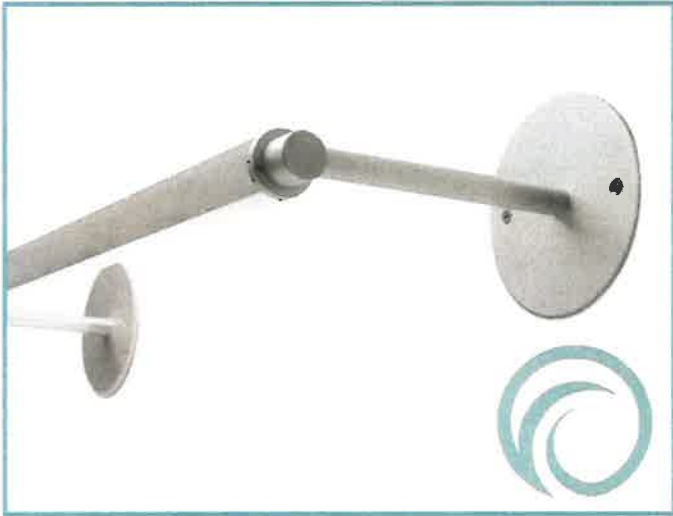

FEATURES

The BSW501 is a wet location, arm mounted LED luminaire, ideally suited for wall wash and facade lighting. The Ø1-3/8" extruded aluminum housing rotates on slender aluminum arms for flexible aiming. Each fixture is paired with a remote mounted, wet location 0-10V dimming or non-dimming driver and housing.

SPECIFICATIONS

Fixture housing constructed of an extruded aluminum tube, frosted acrylic extruded lens and sheet aluminum end caps

Fixture arms are constructed of zinc plated steel pipe Ø5/8" extruded aluminum sleeves and machined aluminum end cap couplers.

Includes Ø4-3/4" aluminum plate for mounting to 4" octagonal wall boxes (by others).

Standard finishes as shown below

Single and continuous run fixtures available with arm center distances of 2'-5' nominal

Arms allow fixture to project from a wall or roofline nominally 3", 6" or 12"

Fixture housing rotates 332° and is locked in place with hex fastener

Fixture wired with 10' low voltage leads (measured from the end cap)

Included remote 120-277V wet location driver offered with 0-10V dimming or non-dim and surface mount aluminum enclosure

Standard outputs are 355, 710 and 915 lumens per foot

LEDs available in 2700K, 3000K, 3500K and 4000K, within a 3 step MacAdam ellipse, all with 80+ CRI typical

Life: 50,000 hours L₇₀

Limited five year warranty

UL and C-UL listed for wet locations

SECTION

PROFILE

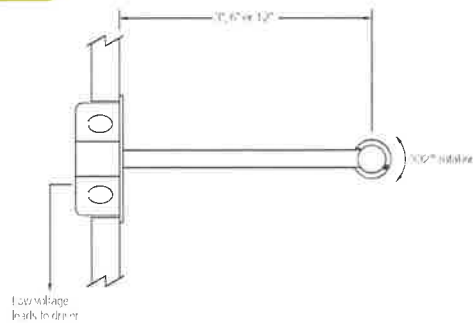
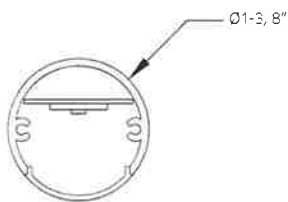

PERFORMANCE

NOMINAL LENGTH	OUTPUT	LUMENS/ft.	WATTS/ft.	LUMINAIRE LUMENS	EFFICACY (LPW)
4'	L: low	355	4.0	1450	89
	R: regular	710	8.0	2904	89
	H: high	915	10.3	3737	89

Note: All data reflects fixtures with 3500K LEDs



BSW501 -

ARM CENTER DISTANCE

- 2: 26"
- 3: 38"
- 4: 50"
- 5: 62"
- 48", 72", 96"**

CORRELATED COLOR TEMPERATURE

- 27: 2700K-80+ CRI
- 30: 3000K-80+ CRI
- 35: 3500K-80+ CRI
- 40: 4000K-80+ CRI

DRIVER

- [remote]
- RN: non-dimming
- RD: 0-10V dimming, 5%

LIGHT OUTPUT (lumens per foot)

- L: low - 355
- R: regular - 710
- H: high - 915

NOMINAL ARM LENGTH

- 3: 3"
- 6: 6"
- 12: 12"**
- CF: consult factory for custom arm length

RUN CONFIGURATION

- SN: single
- ST: starter
- AD: adder
- TR: terminator

FINISH

- AW: architectural white (semi-matte)
- WH: white (semi-gloss)
- BL: black (semi-matte)**
- MB: matte black
- ESS: environmental satin silver
- BZ: bronze
- PR: primer
- CF: consult factory for custom finish

Note: Each fixture includes a remote driver matched for fixture length and light output.

MOUNTING

DESCRIPTION

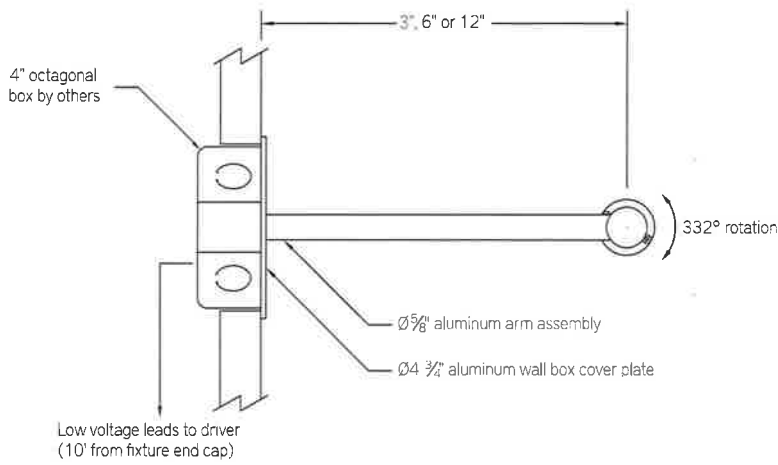

- Ø 1-3/8" LED housing with frosted lens
- Aluminum end cap/arm couplers
- Threaded arm tube
- Aluminum arm sleeve
- Ø 4-3/4" wall box mounting plate
- Flat head Phillips mounting plate screw

EPA CALCULATIONS

LENGTH ORDERING CODE	EPA
2	0.27 ft ²
3	0.38 ft ²
4	0.51 ft ²
5	0.62 ft ²

