

# SUBMITTAL



## Document Contact Information

---

Planning Department staff provides consultations for developing within the River North Urban Design Overlay. Call (615) 862-7190 to schedule a meeting.

 The Planning Department does not discriminate on the basis of age, race, sex, color, national origin, religion or disability in access to, or operation of, its programs, services, and activities, or in its hiring or employment practices. For ADA inquiries, contact ADA Compliance Coordinator, at 862-7150. For Title VI inquiries contact Human Relations at 880-3370. For all employment-related inquiries call 862-6640.

# Table of Contents

<b>Section I: Introduction . . . . .</b>	<b>4</b>	Mechanical, Service and Loading . . . . .	50
History and Intent . . . . .	4	Fences and Walls . . . . .	52
How to Use this Document. . . . .	6	Open Space . . . . .	53
Regulating Plan . . . . .	7	Bonus Height Program . . . . .	55
Compliance . . . . .	8	LEED and LEED ND . . . . .	56
Modifications . . . . .	9	Pervious Surface . . . . .	57
		Upper Level Garage Liner . . . . .	57
		Underground Parking. . . . .	57
		Public Parking. . . . .	57
		Adaptable Garage Levels . . . . .	58
		Shared Parking . . . . .	58
		Civil Support Space . . . . .	58
		Public Open Space . . . . .	59
		Public Greenway . . . . .	59
		Inclusionary Housing. . . . .	59
<b>Section II: Subdistrict Standards . . . . .</b>	<b>11</b>		
Subdistrict 1 . . . . .	12		
Subdistrict 2 . . . . .	14		
Subdistrict 3 . . . . .	16		
<b>Section III: General Standards . . . . .</b>	<b>19</b>		
Measurements . . . . .	20		
Base Zoning Clarifications . . . . .	20		
Step-backs . . . . .	20		
Frontages . . . . .	21		
Build-to Zone . . . . .	22		
Entrances . . . . .	22		
Active Use . . . . .	22		
Glazing and Massing . . . . .	23		
Frontage Types . . . . .	24		
Storefront Frontage. . . . .	24		
Stoop Frontage . . . . .	26		
Porch Frontage . . . . .	28		
Civic Frontage . . . . .	30		
Canopies and Awnings . . . . .	31		
Street Character . . . . .	32		
River North Proposed Street Network. . . . .	34		
Street Trees . . . . .	36		
Building Materials . . . . .	37		
Parking and Access . . . . .	38		
Specific to Structured Parking . . . . .	39		
Specific to Surface Parking . . . . .	40		
Structure Height Regulation . . . . .	41		
Parking Garage Treatment . . . . .	42		
Cladding. . . . .	42		
Upper Level Garage Liner . . . . .	43		
Parking Garage Cladding . . . . .	44		
Screening . . . . .	44		
Solid Wall . . . . .	46		
Parking Garage Treatment . . . . .	48		
Innovative Design. . . . .	48		
Lighting . . . . .	49		
		<b>Appendix . . . . .</b>	<b>61</b>
		Development Capacity Evaluation Study. . . . .	62

# Section I: Introduction

## Introduction

### History and Overview

The East Nashville Community includes a portion of the “East Bank”—the area on the east bank of the Cumberland River. The bulk of the East Bank is in the Downtown Community; however, a portion of the East Bank from Spring Street on the south to the I-24/I-65 interchange to the north is in the East Nashville Community. This area is commonly referred to as “River North.” For years, this area has been home to light industrial and warehousing businesses and it also experienced severe flooding during the flood of 2010. As downtown redevelops, developers are looking to the East Bank, including the northern portion in East Nashville, for redevelopment opportunities. This area is envisioned to redevelop to much greater intensity, with much taller buildings, capitalizing upon its river location and proximity to downtown.

The East Nashville Community Plan was last updated in June of 2015. At that time the plan encouraged additional density, height and development in this area, so long as it remains sensitive to the property’s relationship to the river and is consistent with the goals and objectives articulated in the Community Character Manual and the East Nashville Community Plan. Consequently, the Planning Staff, in coordination with the primary landowner in the area who owns over 100 + acres on the East Bank, have developed this UDO in an effort to put in place a user friendly form based code to align the development standards to the goals and policies in the community plan and NashvilleNext.

### Intent

The goals of the Urban Design Overlay are as follows:

- Establish a compact mixed use development pattern distributed along a system of streets that transitions in scale from the core to the neighborhood.
- Ensure that buildings are oriented to and linked by a cohesive pedestrian system.
- Encourage a balance of transportation options for pedestrians, bicycles, vehicles and transit.
- Encourage high quality (function and aesthetic) open spaces for assembly, relaxation, civic events, display of public art and other similar purposes.
- Encourage a high level of pedestrian-generating activity along streets and a pedestrian friendly environment.
- Encourage environmentally sensitive development and green space.



# Section I: Introduction

## Location

River North is a mixed-use, urban, downtown neighborhood, located along the East bank of the Cumberland River.



# Section I: Introduction

## How to Use this Document

---

This document is to be used by developers, property owners, government officials, residents, and any individual who is interested in development or redevelopment of any property located within the UDO boundary.

A UDO is a zoning tool that requires unique physical design standards for development or redevelopment within a designated area that would otherwise not be ensured by the standard provisions of the zoning regulations. A UDO can modify base zoning standards such as setbacks, building height, floor area ratio, and parking per the provisions outlined in Section 17.36.320 of the Zoning Code. The standards established in this document vary from the underlying base zone district standards for the properties in the UDO. All provisions are regulatory in nature and have the same force and effect as the zoning regulations of the Metro Code. Any final plans submitted for approval under the UDO will be reviewed for adherence to these provisions and to the provisions of the base zoning that are not varied by the UDO. If a final plan is consistent with the UDO and the zoning standards it can be approved administratively by the Executive Director as expressed in the Planning Commission's bylaws and as clarified here.

The design standards established in the UDO are intended to direct future development in a manner that addresses strategies for site design including placement, massing and orientation of buildings, architectural treatment, landscaping and screening, general access and parking, and signage. In some instances, desired standards that are beyond the authority of the zoning ordinance accompany the goals and objectives. These desired standards pertain to areas for which Metropolitan Government exercises final authority over design, construction and operation of facilities, such as public rights-of-way and stormwater detention and conveyance. The incorporation of these standards into any final development construction plans will depend on Metropolitan Government review for consistency with policies, laws, and related standards of various departments.

## Overlapping Plans

Within the UDO boundary area, there may exist other regulations and design guidelines intended to work in conjunction with the UDO. Property owners and developers should consult with all departments and agencies during the development process to address any and all rules, regulations and policies. Property owners should consult with Metro Planning and Public Works to make the necessary improvements to the streetscape in accordance with the Major and Collector Street Plan and the Strategic Plan for Sidewalks and Bikeways and Title 17.20.120 Provision of sidewalks.

- If a property is zoned Specific Plan then all standards contained with the Specific Plan shall apply and the UDO standards would apply for any standard not addressed in the SP.
- If a property has a Planned Unit Development Overlay then the standards of the PUD shall apply and the UDO standards would apply for any standards not addressed in the PUD.

## Subdistricts

The River North UDO is organized by Subdistricts, as identified on the Regulating Plan. Subdistricts are smaller districts within the larger UDO area that are envisioned to have unique character and development standards.

To determine the standards which apply to a particular property:

- On the Regulating Plan, identify the Subdistrict in which the property is located.
- Consult the Subdistrict Standards section for the development standards relevant to the Subdistrict.
- Consult the General Standards section for guidance on development standards for all Subdistricts.

# Section I: Introduction

## Regulating Plan

The Regulating Plan is the official zoning map of the UDO. The Regulating Plan shows the Subdistricts that govern the development standards for each property.



 Subdistrict 1

 Primary Streets

 Subdistrict 2

 Secondary Streets

 Subdistrict 3

 Tertiary Streets

# Section I: Introduction

## Compliance, Modifications and Design Review

---

### **Compliance**

All provisions of the Metro Zoning Code shall apply, unless otherwise addressed by the River North UDO standards. The UDO standards shall apply as follows:

#### **New Development:**

Full Compliance with all standards of the UDO and improvements to the sidewalk corridor must be made in accordance with the Major and Collector Street Plan.

#### **A new structure on a lot with existing building(s):**

To the extent practicable, the new structure shall be in compliance with applicable standards of the UDO and shall not increase any degree of non-conformity and improvements to the sidewalk corridor must be made in accordance with the Major and Collector Street Plan.

#### **An addition of 25 percent or less of the square footage of the existing building:**

To the extent practicable, any addition shall attempt to comply with the applicable standards of the UDO.

#### **An addition of more than 25 percent of the square footage of the existing building:**

To the extent practicable any addition shall comply with the standards of the UDO and improvements to the sidewalk corridor must be made in accordance with the Major and Collector Street Plan.

#### **Redevelopment after demolition of over 50 percent of the structure:**

Full Compliance with all standards of the UDO and improvements to the sidewalk corridor must be made in accordance with the Major and Collector Street Plan.

#### **Redevelopment of existing riverfront building:**

For the property located on the river, commonly referred to as “Cherokee Marine,” the property may be redeveloped and deviations from the UDO shall be permitted at the staff level. The development shall try, where possible, to comply with the terms of this UDO and the permitted uses in the base zone shall apply. Nevertheless, development shall be encouraged and allowed, including deviations, so long as the overall plan is consistent with the intent and purpose of the UDO.

#### **Signage Compliance:**

- New signs shall comply with all Signage Standards.
- Existing legally non-conforming signs shall not increase the degree of non-conformity.



# Section I: Introduction

## Modifications to the Standards

Based on site-specific issues, an applicant may seek modifications to the standards of this document. Any standard within the UDO may be modified, insofar as the intent of the standard is being met, the modification results in better urban design for the neighborhood as a whole, and the modification does not impede or burden existing or future development of adjacent properties.

The River North UDO, the East Nashville Community Plan, the Major Street and Collector Plan, and any other policies and regulations from governing agencies shall be consulted when considering modifications.

- Modifications may be approved by Planning staff, the Planning Commission or MDHA's Design Review Committee:
- Minor modifications – deviations of 20 percent or less, or minor deviations in non-numerical standards – may be approved by Planning Staff.
- Any determination made by the Planning Staff may be appealed to the Planning Commission.
- Major modifications – deviations of more than 20 percent– and major deviations from non-numerical standards may be approved by either the Planning Commission or the MDHA Design Review Committee.
- For any property that falls within an MDHA Redevelopment District the Design Review Committee shall have jurisdiction to approve deviations.
- For modifications to overall height, the Executive Director of the Planning Department shall determine whether the developer has made reasonable efforts to use all appropriate bonuses. The Executive Director's decision may be appealed to the MDHA DRC. If it has been determined that all reasonable efforts have been made to use the Bonus Height Program, the applicant shall hold a community meeting with the property owners within 300 feet , providing notice to these owners, and the Planning Commission shall review the modification request and may grant additional height for exceptional design including but not limited to unique architecture, exceptionally strong streetscape and improvements to the project's relationship to surrounding properties.

## Variances and Special Exceptions

Variances and special exceptions that are not specifically for standards of the River North UDO shall follow the procedures of the applicable chapters of the Zoning Code.

Variances and special exceptions shall not be applicable to the height standards of the UDO which are governed by the earlier procedure reference above. Standards specific to the River North UDO may be modified based on the Modifications section of this document.

## Civic Buildings

For Civic Buildings within the UDO:

- The Metro Planning Commission or its designee shall make the final determination of compliance with the UDO standards.
- Civic Buildings within the River North UDO shall be iconic, shall not be prototypical design, and must respond to the materiality and form of the surrounding context.

# Section I: Introduction

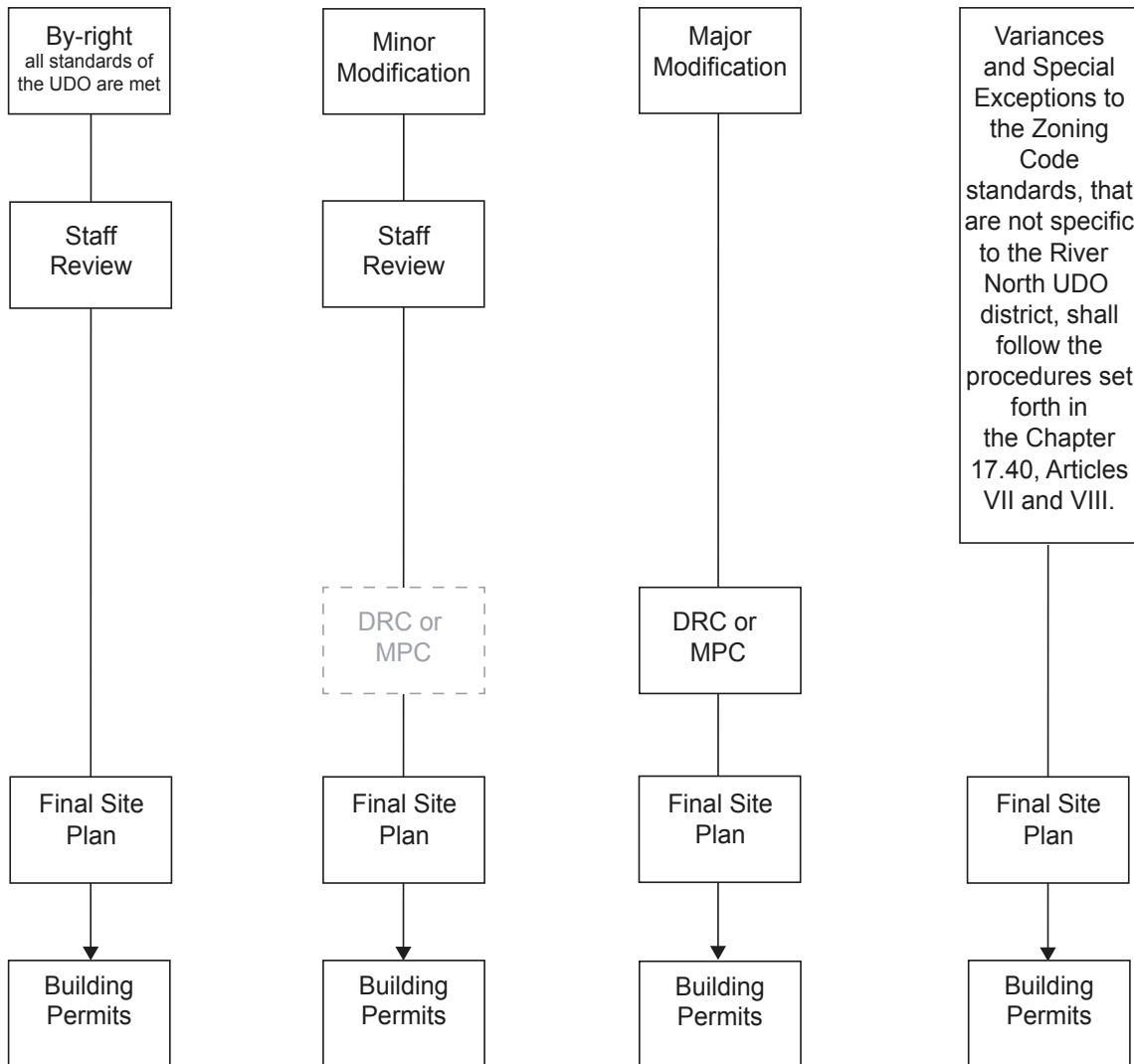

# Section II: Subdistrict Standards

# Section II: Subdistrict Standards

## Subdistrict 1: Regulating Plan



Subdistrict 1

# Section II: Subdistrict Standards

## Subdistrict 1: Building Regulations

### Frontage

<b>A Build-to Zone</b>	0'-15'
<b>B Facade Width</b>	
Primary Streets	60% of lot frontage min.
Secondary Street	40% of lot frontage min.

<b>C Min. building depth</b>	15' from building facade
------------------------------	--------------------------

### Height

<b>D Min.</b>	1.5 times half of the adjacent-right of-way for 80% Facade Width along Primary or Secondary Streets
<b>E Max.</b>	10 stories

### Step-back \*

Step-back required on all streets and Open Space

<b>F Step-back between</b>	
Buildings taller than 7 stories	1st and 8th stories
<b>G Min. step-back depth</b>	15'

### Side & Rear Setbacks

<b>H Min.</b>	0'
---------------	----

### Sidewalk & Planting

Improvements to the sidewalk corridor according to the General Standards and the Major and Collector Street Plan

\* See page 20 for full description of step-back.

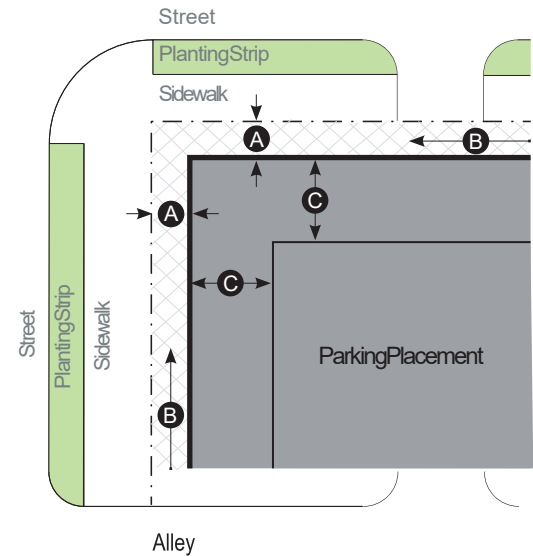

Building Plan

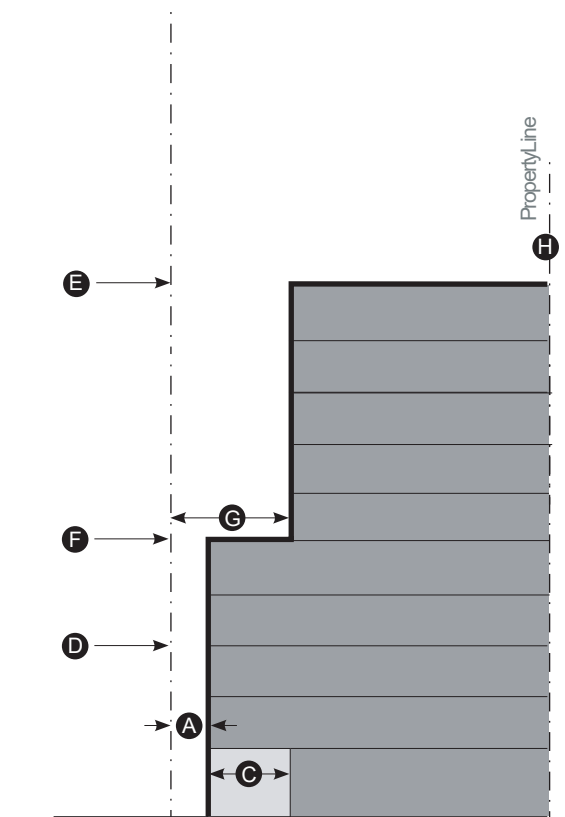

Building Section

# Section II: Subdistrict Standards

## Subdistrict 2: Regulating Plan



Subdistrict 2

# Section II: Subdistrict Standards

## Subdistrict 2: Building Regulations

### Frontage

**A Build-to Zone** 0'-15'

**B Facade Width**  
 Primary Streets 60% of lot frontage min.  
 Secondary Street 40% of lot frontage min.

**C Min. building depth** 15' from building facade

### Height

**D Min.** 1.5 times half of the adjacent-right of-way for 80% Facade Width along Primary or Secondary Streets

**E Max.** 15 stories  
 Additional height available through the Bonus Height Program

#### Step-back \*

Step-back required on all streets and Open Space

**F Step-back between**  
 Buildings taller than 7 stories 1st and 8th stories

**G Min. step-back depth** 15'

### Side & Rear Setbacks

**H Min.** 0'

### Sidewalk & Planting

Improvements to the sidewalk corridor according to the General Standards and the Major and Collector Street Plan

\* See page 20 for full description of step-back.

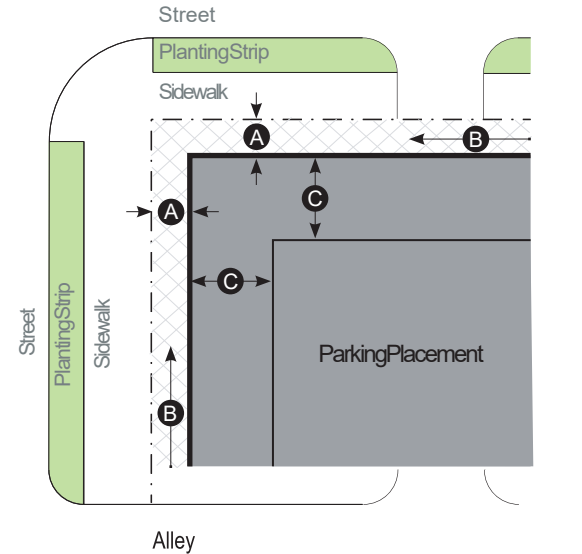

Building Plan

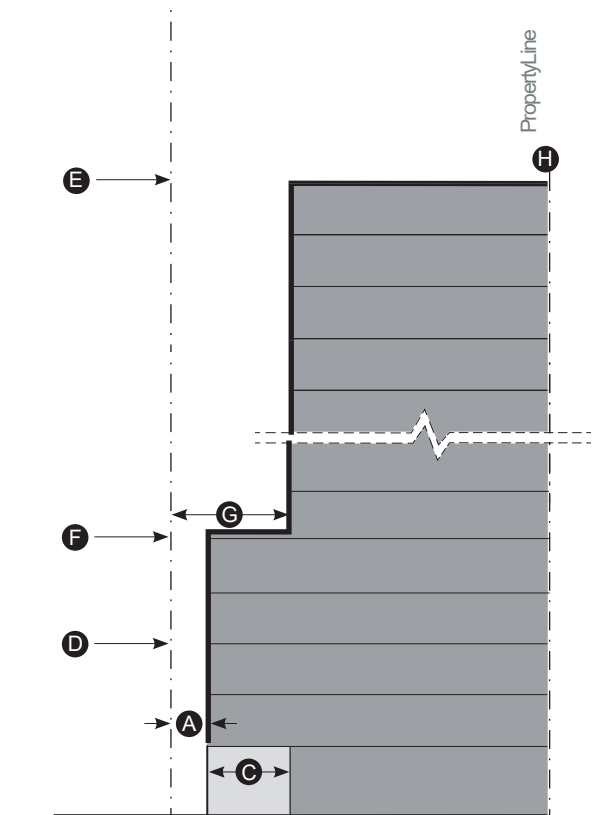

Building Section

# Section II: Subdistrict Standards

## Subdistrict 3: Regulating Plan

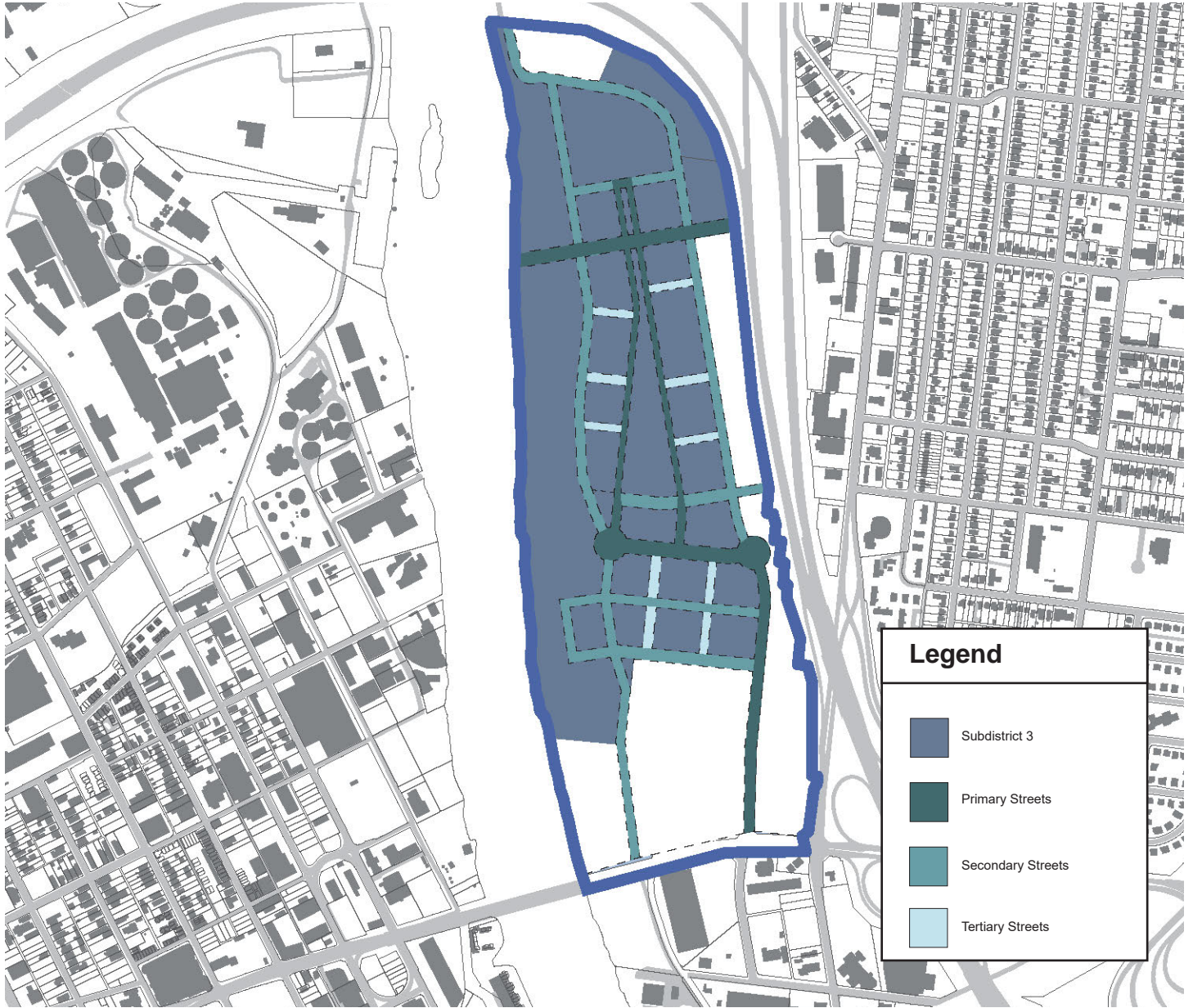

Subdistrict 3



# Section II: Subdistrict Standards

## Subdistrict 3: Building Regulations

### Frontage

<b>A Build-to Zone</b>	0'-15'
<b>B Facade Width</b>	
Primary Streets	60% of lot frontage min.
Secondary Street	40% of lot frontage min.
Remaining lot frontage may be used for pedestrian amenities and shall not be used for parking.	
<b>C Min. building depth</b>	15' from building facade

### Height

<b>D Min.</b>	1.5 times half of the adjacent-right of-way for 80% Facade Width along Primary or Secondary Streets
<b>E Max.</b>	30 stories
Additional height available through the Bonus Height Program	

#### Step-back \*

Step-back required on all streets and Open Space

<b>F Step-back between</b>	
Buildings taller than 7 stories	1st and 8th stories
<b>G Min. step-back depth</b>	15', for 40% of lot frontage min.

### Side & Rear Setbacks

<b>H Min.</b>	0'
---------------	----

### Sidewalk & Planting

Improvements to the sidewalk corridor according to the General Standards and the Major and Collector Street Plan

\* See page 20 for full description of step-back.

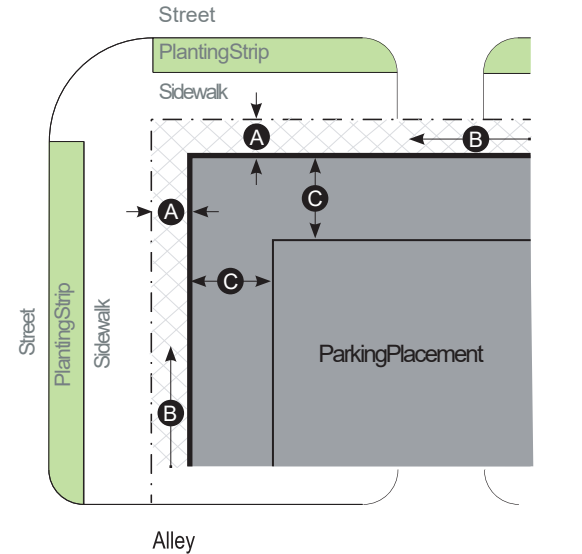

Building Plan

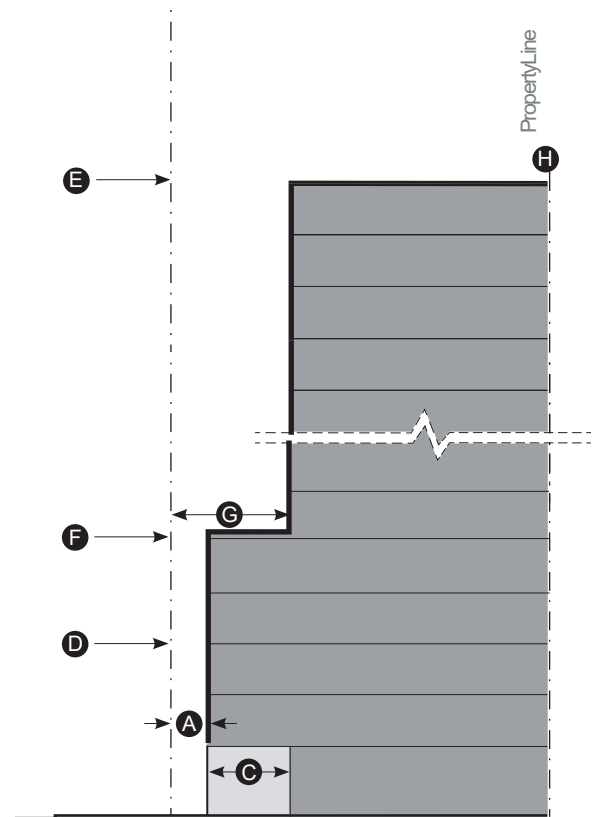

Building Section

This page left intentionally blank

# Section III: General Standards

# Section III: General Standards

## General Standards

---

### Measurement from “Grade”

- Unless otherwise indicated, reference to measurements of height shall be calculated using the average elevation along the public right-of-way fronting the property. Thus, grade will generally be measured from the public sidewalk, not from grade on site.
  - When buildings are set back from the property line more than 15 feet, grade shall be measured as the average existing elevation at the building façade.
- In the event that the base flood elevation, as established by FEMA, is higher than the sidewalk or grade elevations, the height of the first story, shall be measured from 1 foot above the base flood elevation.

### Measurement of Height

- Unless otherwise specified herein, the height of buildings shall be measured in stories.
- The maximum height for an individual story shall not exceed 25 feet from finished floor to finished floor for each of the first 2 stories, 18 feet floor to floor above the second story, and 25 feet for the top story of buildings greater than 5 stories.
- Where a parking liner exists, 2 liner stories shall be counted as a single story, and any number of parking levels may be concealed behind it.
- The maximum height for a raised foundation is 6 feet above grade.
- Basements are not considered stories for the purposes of determining building height.
- Building height shall be measured from each Street Frontage (excluding alleys) or Open Space.
- The height of fences, walls and hedges shall be measured in feet from the average sidewalk elevation.

### Base Zoning Clarifications

- All properties within the UDO shall be exempt from the Floor Area Ratio (FAR) requirements of the underlying base Zoning districts.
- All properties within the UDO shall be exempt from the Height Control Plane, height limitations, Step-back, and front, rear, and side Setback requirements of the underlying base Zoning districts (including Height Control Planes from adjacent residential districts).
- Impervious Surface Ratio is per the base Zoning District.
- There is no minimum lot size within the UDO.
- Landscaping standards and required buffers shall be controlled by the general standards of this document and are exempt from the requirements of the base Zoning districts.
- Plans within the River North UDO shall comply with the Metro Tree Ordinance Standards.

### Step-backs

- Within the River North UDO, the step-back is defined as the required minimum distance the upper stories of a building must be stepped back from the outer edge of the build-to-zone, along all applicable frontages.
- To allow for massing variation, stories within the range may be permitted to step-back to a lesser extent or not at all, so long as the minimum step-back depth is met by the required step-back story.

# Section III: General Standards

## General Standards

---

### Frontages

A Frontage is the specific way in which the building face addresses the street. It is the transition and interaction between the private and public realms. Building Frontages define the character and form of the public spaces within each neighborhood. The following standards shall apply to all development within the River North UDO.

- Buildings shall front a street (excluding alleys), open space, and/or a pedestrian passage.
- Facade Width
  - The minimum facade width is the minimum amount of the frontage that must be defined by a building, and is designated as a percentage of the frontage.
  - Every property shall establish one Principal Frontage along a street.
  - When a lot fronts more than one street the following priority shall be given when establishing the Principal Frontage: Primary Street, Secondary Street, Tertiary Street, Other Street.
  - In the instance a property fronts multiple Primary Streets, any may be chosen as the Principal Frontage.
  - Along a Minor Frontage, modifications may be granted for the reduction of ground level garage Liners and or glazing requirements.
  - For parcels larger than [1] Acre in size, frontage requirements may be further reduced by minor modification.
- Open Space Frontages
  - Facade width and active use requirements shall apply to these frontages the same as a street frontage.
  - All buildings fronting open space shall have a minimum of one primary pedestrian entrance on the open space.

## Section III: General Standards

### General Standards

---

#### Build-to Zone

- The Build-to Zone is the specified depth along a property's street frontage(s) in which the required minimum facade width must be located.
- Depending on site conditions, the front of the Build-to Zone may begin at different locations.
  - When the existing streetscape and sidewalk meets with the Major and Collector Street Plan, the Build-to Zone begins at the back of the required streetscape (including sidewalk zones).
  - When the existing streetscape and sidewalk does not meet with the Major and Collector Street Plan, the sidewalk shall be widened on site and the Build-to Zone begins at the back of the new streetscape (including sidewalk zones).
  - When utility or pedestrian easements exist along the street frontage of a property, the Build-to Zone shall begin at the back of the easement.
  - When buildings front an Open Space, the Build-to Zone shall begin at the back of the Open Space.
- Attachments
  - Structures, including porches, stoops, and balconies may encroach into the Build-to Zone.
  - Elements such as stairs, awnings, and landscaping may encroach beyond the Build-to Zone. Any encroachments into the right-of-way must follow the Mandatory Referral process.
- When calculating the minimum facade width, access to structured parking shall not be counted as part of the required facade width, and access to surface parking shall not be counted part of the required facade width. That is, access to surface parking is allowed in the "remaining" area, after the facade width requirement has been met.

#### Entrances

- All buildings shall have at least one direct functional pedestrian entrance, along the principal frontage. This may be access to a lobby shared by individual tenants.
  - Whether opening to the circulation network or other public space, the functional entry must be connected to a sidewalk or equivalent provision for walking.
  - If the public space is a square, park, or plaza, it must be at least 50 feet (15 meters) deep, measured at a point perpendicular to each entry.
- Buildings with multiple ground floor commercial tenants shall provide at least one direct pedestrian entrance for each tenant space oriented to the frontage, or submit a shared access plan for staff review.
- Corner entrances are appropriate on corner lots.

## Section III: General Standards

### General Standards

---

#### Active Use

- An active ground floor use requirement shall mean a habitable space occupied by retail, office, residential, institutional or recreational uses, specifically excluding parking and mechanical uses. Minimum 15 feet in depth.
- Active uses are those programmed spaces that generate pedestrian street activity and interaction. Hallways, storage rooms, fitness centers, and other ancillary spaces shall not qualify as an active use.
- An active use is required on the ground floor of all streets, open spaces and greenways other than Tertiary streets.
- The term “active use” and ground level “building liner” are synonymous.
- Active ground floor uses must match the facade width percentage requirements. For example, if 60% facade width min. is required along a lot’s frontage, then 60% min. of the lot’s frontage must also consist of an active ground floor use.

#### Glazing and Massing

- Openings for vehicular access to parking structures on the first floor shall be included in calculation of total facade area.
- All street and open space level exterior windows must have a minimum light transmission of 60 percent.
  - Modifications may be permitted in so far as it is determined that tinting does not substantially diminish the effect of the building wall or the pedestrian character of the street.

## Section III: General Standards

### Frontage Types: Storefront Frontage

The Storefront Frontage has a limited Build-to Zone that is close to the street, with building entrances accessible at sidewalk grade. The Storefront Frontage has substantial glazing on the facade at ground level, space for pedestrian-oriented signage, awnings, retail display, and other design features conducive with creating an active commercial streetscape.

The Storefront Frontage is commonly used for general commercial, office, retail, restaurant, lobby, etc.





# Section III: General Standards

## Frontage Types: Storefront Frontage

### Storefront Frontage

<b>A</b> Max. sill height	3 ft
<b>B</b> Min. ground floor height	14 ft from grade
<b>C</b> Min. upper floor(s) height	10 ft floor to floor
<b>D</b> Min. ground floor glazing*	Principal Frontage 40% floor to floor Minor Frontage 30% floor to floor
<b>E</b> Min. upper floor(s) openings	25% from floor to floor

#### Notes

Where Storefront frontage is allowed, modifications may be given to allow for a Storefront arcade. All Storefront Frontage standards shall be met on the facade behind the arcade.

\*All grade-level retail shall provide clear vision glass between 3' and 8' above grade for a minimum of 60% of its frontage area.

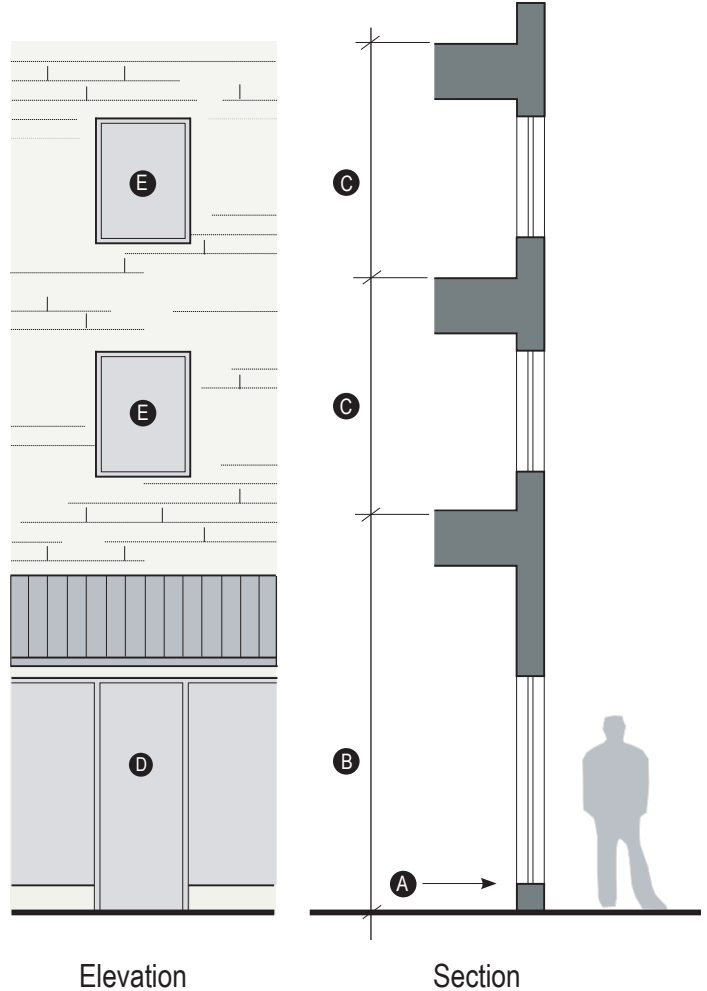

## Section III: General Standards

### Frontage Types: Stoop Frontage

The Stoop Frontage has a limited to moderate Build-to Zone with the first floor elevated from the sidewalk grade. This frontage type utilizes a stoop - a small landing connecting a building entrance to the sidewalk by a stair or ramp - to transition from the public sidewalk or open space into the building.

Stoops are generally provided externally, but may be provided internally as necessitated for ADA compliance.

The Stoop Frontage is generally used for residential and live-work buildings, but may be appropriate for other uses.



# Section III: General Standards

## Frontage Types: Stoop Frontage

### Porch Frontage

**A First floor elevation**

Min.	24" from grade
Max.	5 ft from grade

**B Min. ground floor openings** 30% floor to floor

**C Min. upper floor(s) openings** 25% from floor to floor

**Stoop**

- D** Min. porch depth 5 ft
- E** Stoops may extend into the Build-to Zone.
- F** Steps may extend into the Build-to Zone, but may not encroach into the public Right-of-Way.

**Notes**

Greater first floor elevation allowed by modification for:

- Property with significant elevation change across the site at the street frontage.
- Development that incorporates below grade basement floors that are accessible from the exterior of the building.

Transition to first floor elevation may be accommodated on the interior of the building to allow for compliance with ADA accessibility requirements.

Entries shall not be recessed more than 4 feet from the facade of the building.

Doors shall face the street.

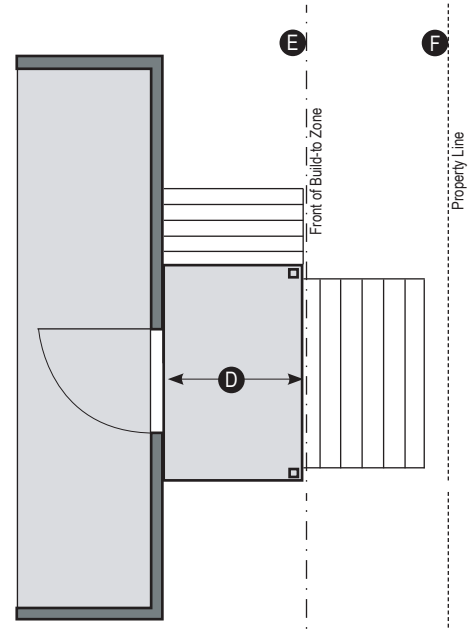

Plan

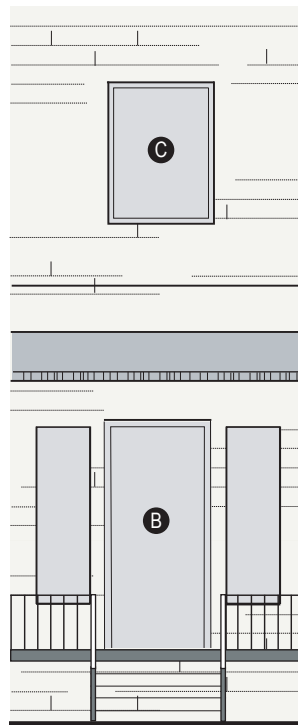

Elevation

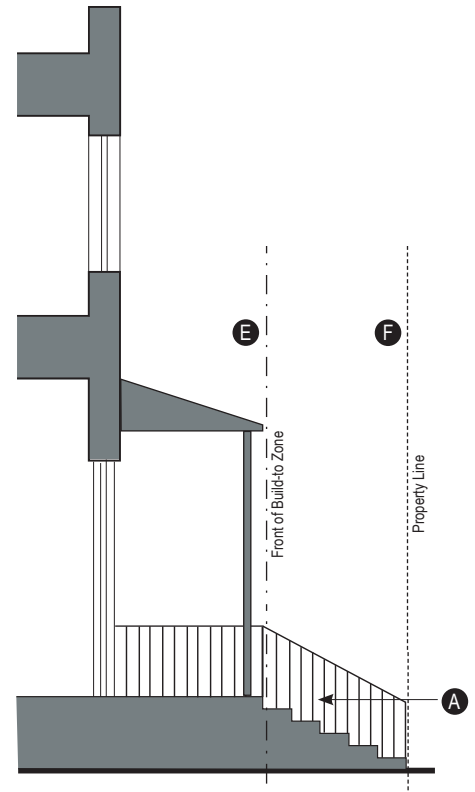

Section

## Section III: General Standards

### Frontage Types: Porch Frontage

The Porch Frontage has a moderate Build-to Zone with the first floor elevated from the sidewalk grade. The Porch Frontage utilizes a porch - an open air room appended to the mass of a building with floor and roof but no walls on at least two sides - to transition from the public sidewalk or open space into the building.

The Porch Frontage is primarily used for residential buildings.



# Section III: General Standards

## Frontage Types: Porch Frontage

### Porch Frontage

#### A First floor elevation

Min.	18" from grade
Max.	5 ft from grade

#### B Min. ground floor openings

30% floor to floor

#### C Min. upper floor(s) openings

25% from floor to floor

#### Porch

- D Min. porch depth 5 ft
- E Porches may extend into the front of the Build-to Zone.
- F Steps may extend into the Build-to Zone, but may not encroach into the public Right-of-Way.

#### Notes

Greater first floor elevation allowed by modification for:

- Property with significant elevation change across the site at the street frontage.
- Development that incorporates below grade basement floors that are accessible from the exterior of the building.

Transition to first floor elevation may be accommodated on the interior of the building to allow for compliance with ADA accessibility requirements.

Entries shall not be recessed more than 4 feet from the facade of the building.

Doors shall face the street.

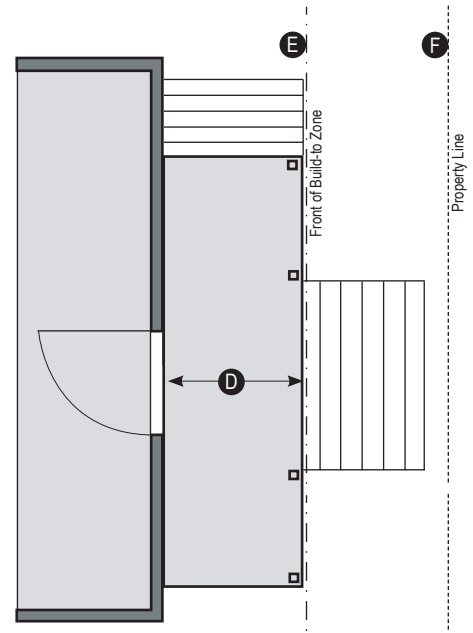

Plan

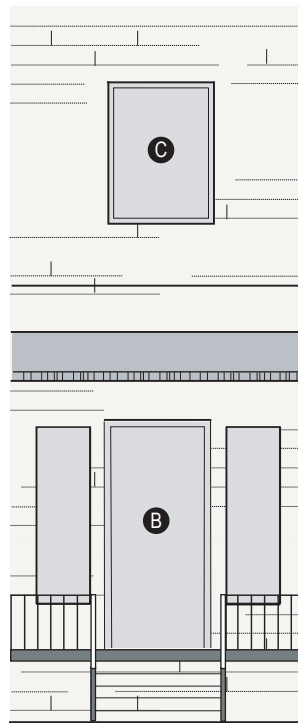

Elevation

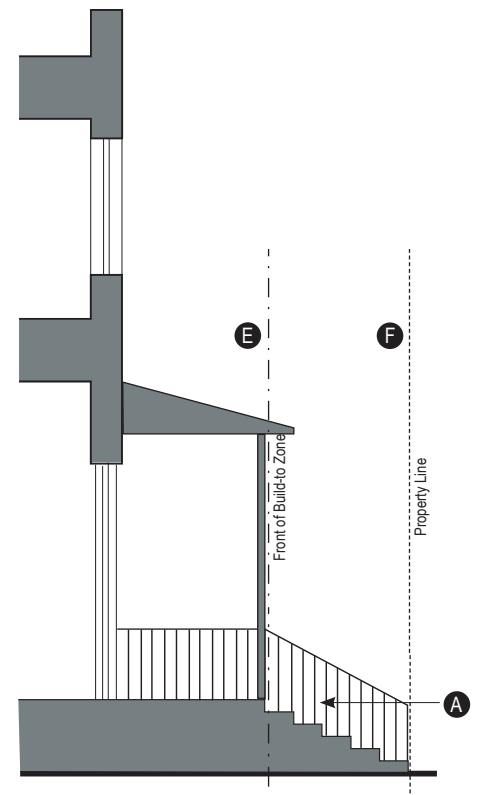

Section

## Section II: General Standards

### Frontage Types: Civic Frontage

Civic buildings are designed and constructed for community use or benefit by governmental, cultural, educational, public welfare, or religious organizations. Civic buildings are inherently unique structures that present opportunities for unusual and iconic design within the urban fabric.

Civic buildings should be designed with prominence and monumentality.

A Civic building shall be oriented to streets and public spaces and follow the intent of the particular subdistrict in which it is located with regard to pedestrian orientation, massing, and articulation.

Key architectural features should act as community focal points. Where possible, street axes should be terminated by the primary building form or architectural feature. Towers, spires, and other vertical forms are encouraged.

Civic buildings may include the following: community buildings, libraries, post offices, schools, religious institutions, publicly owned recreational facilities, museums, performing arts buildings, and municipal buildings.

Civic buildings shall be reviewed by modification pursuant to the procedure outlined on page 9 of the UDO.



# Section III: General Standards

## Canopies and Awnings

### Canopies

<b>A Clearance</b>	
Minimum from sidewalk	8'
Maximum	25'
<b>B Maximum projection</b>	within 2' of curb
<b>C Maximum canopy height</b>	4'

Encroachments in the public right-of-way must meet Metropolitan Government's current clearance standards and be approved under the mandatory referral process prior to installation.

### Awnings

<b>A Clearance</b>	
Minimum from sidewalk	8'
<b>B Maximum projection</b>	
First floor	4' from facade
Upper floors	not permitted
<b>C Maximum awning height</b>	5'

The name and logo of the establishment are the only advertising permitted on awnings. All shall follow the Sign Standards.

No awning shall exceed 25 feet in length.

Awnings shall not be constructed of materials that are glossy in finish.

Encroachments in the public right-of-way must meet Metropolitan Government's current clearance standards and be approved under the mandatory referral process prior to installation.

Canopy and Awning standards do not apply to brise soleil or sunshades.

### Auto-oriented canopies and awnings

Auto-oriented canopies and awnings, for uses such as drive-thrus and gas station pumps, may be attached to a building according to the following:

- The building shall comply with all Frontage standards.
- The canopy and/or awning shall be lower in height than the primary building.
- The setback of the canopy and/or awning shall be a minimum of 15 feet from the back of the front facade of the building.
- A drive-through canopy and/or awning shall not be located along the principal frontage.

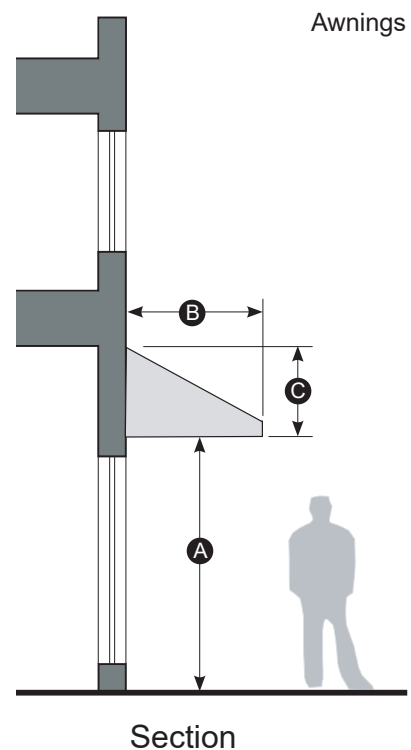
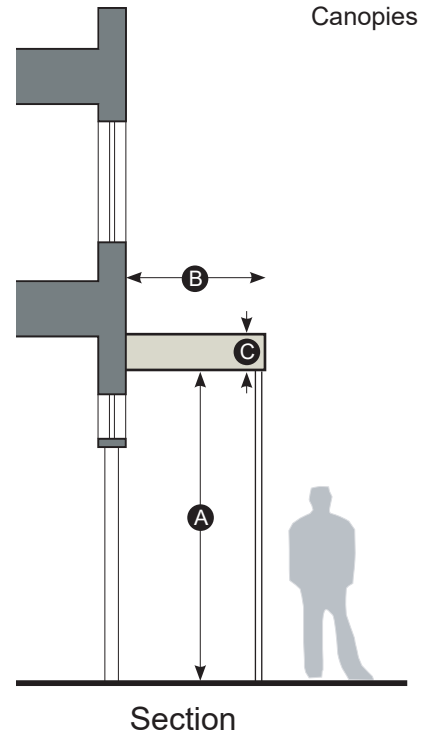

## Section III: General Standards

### Street Character

---

The public right-of-way, including streets, sidewalks and public utility infrastructure, plays both a functional and social role in the life of the city and its citizens. Streets organize the city, help to define space, and link destinations. The street is also a public place where people congregate, shop, socialize and live. Active, attractive streets are critical to the continued growth and success of River North. The UDO includes urban design tools to make working, living and playing in River North lively, safe and comfortable.

The UDO uses Street Types as an urban design and organizing tool. All streets are classified on the Regulating Plan as Primary, Secondary, Tertiary, Other, or Alley. The location of vehicular access from all other streets shall be determined on a case-by-case basis. NashvilleNext calls for a strong emphasis on expanding other modes of transportation including walking, cycling and transit. The UDO emphasizes walking, cycling and transit as primary modes of transportation within River North through the urban design of individual buildings, blocks, and neighborhoods.

#### All Streets

- Streets refer to publicly or privately owned right-of-way. They are intended for use by pedestrian, bicycle, transit and vehicular traffic and provide access to property.
- Streets consist of vehicular lanes and the Sidewalk Corridor. The vehicular lanes, in a variety of widths, provide traffic and parking capacity and may include bicycle paths. The Sidewalk Corridor contributes to the urban character of each neighborhood. It may include pedestrian paths, landscaped planters, street furnishings and street trees.
- Pedestrian safety, comfort, and accessibility should be a primary consideration of street design and dimensioning.
- When alleys are present, vehicular access from alleys is encouraged. Vehicular access from public streets shall be considered in the following order: Other Streets, Tertiary Streets, Secondary Streets, and then Primary Streets as approved by Metro departments.
- Final construction plans shall comply with Metro Public Works standards and specifications.

#### Street Types

##### Primary Street

Primary Streets accommodate high levels of pedestrian activity and high levels of vehicular traffic. On Primary Streets, active uses – residential, retail, restaurant or office – lining parking structures and on the first floor of buildings, and restricted vehicular access enhance the pedestrian experience. Primary streets provide the opportunity for more intense, urban development including shallow Build-to Zones and, in some cases, increased building height. Pedestrian comfort on these streets is of highest importance. Primary streets should have a continuous street wall, wide sidewalks between 14 and 20 feet to provide room for street furniture such as benches, trash receptacles, and bicycle parking. Primary Streets have the highest level of urban activity such as, outdoor dining, retail displays, and community activities like markets, parades, and music. Street trees provide protection from the sun and rain, reduce stormwater runoff and air pollution, and provide aesthetic value to the city. Trees should be planted in wells with tree grates to allow for the uninterrupted flow of pedestrian traffic.



## Section III: General Standards

### Street Character

---

#### Secondary Street

Secondary Streets have moderate levels of pedestrian activity and moderate levels of vehicular traffic. Secondary Streets may be mixed-use or more residential in character. The Build-to Zone is generally shallow, and building heights are limited. In mixed-use areas, a continuous street wall should be maintained and sidewalks should be between 12 and 16 feet wide to accommodate pedestrian traffic. In residential areas, the required minimum façade width is limited – allowing for more space between buildings – and sidewalks may be narrower. Both tree wells and open landscaped planters are appropriate depending on sidewalk width.

#### Tertiary Street

Tertiary Streets are the less important than Primary and Secondary streets. They may function as “back of house” for buildings with multiple street frontages. Care should be taken to make these streets as pedestrian-friendly as possible while accommodating loading and access needs. Unless appropriately designed to share street space, an 8 foot sidewalk is a minimal dimension for walking accommodations in a highly urbanized area such as River North.

#### Other Street

Other Streets are streets that do not fall into any of the other street categories. They may have high or moderate levels of vehicular traffic, but often have no access to property and limited pedestrian activity. Building height along these streets is regulated by the other property frontages. Buildings do not front on these streets and may be built up to the property line.

#### Alley

Alleys are service roads that provide shared access to property. Public utilities as well as access to mechanical equipment and trash should be located off an alley whenever possible. Alleys are encouraged for access and loading.

#### Sidewalk Corridor

The Sidewalk Corridor is the portion of the right-of way between the vehicular lanes and the property line or building façade.

- The primary function of the Sidewalk Corridor is to provide a safe, comfortable, and convenient route for pedestrian travel that is separated from vehicular movements.
- The Sidewalk Corridor is a public space that should include pedestrian amenities such as seating, shade trees, bike racks, places to congregate, trash and recycling receptacles and outdoor dining.
- The Sidewalk Corridor may accommodate public utilities such as electric poles and vaults, water and sewer lines, bus stops and traffic signals.
- The Sidewalk Corridor may also accommodate separated bikeway facilities by providing protection to cyclists from traffic. This may be achieved by an adjacent grass strip or planting zone and may function as a dedicated facility meant for cyclists only, or mixed with pedestrian traffic like a multi-use path.
- As property develops, property owners shall consult with Metro Planning and Public Works to make the necessary improvements to the streetscape in accordance with the *Major and Collector Street Plan* and the *Strategic Plan for Sidewalks*.

# Section III: General Standards

## Street Character: Future Streets



Proposed Street Network

## Section III: General Standards

### Street Character: Future Streets

---

#### Future Streets

This area will see significant growth and change over the next few years. The Future Streets Plan show how streets could be realigned, connected and created in the future to improve mobility within the area.

Properties near an area highlighted for change on the Future Streets Plan shall consult with the Planning Department and the Department of Public Works to discuss the potential change.

Any future street listed in the UDO as a future street can be moved or realigned prior to construction and the designation for that street can be changed. When a street is moved, relocated or the designation is changed prior to construction this is a modification that may be approved by the Planning Department with a recommendation from Public Works.

## Section III: General Standards

### Street Character

---

#### Street Trees

Shade-producing street trees shall be planted in the public right-of-way along the length of the lot frontage at a maximum spacing of forty feet or in accordance with the regulations of Metro departments and agencies.

#### Tree Quality

Tree species shall be chosen from the Urban Forestry Recommended and Prohibited Tree and Shrub List based on tree size and planting area provided or an alternative species deemed appropriate by the Urban Forester.

- At planting trees, shall meet the requirements for street trees set out in the American Standard for Nursery Stock.
- All nursery stock used as street trees shall be vigorous, healthy and free of diseases or infestation.
- No species considered invasive in the project's context according to USDA or other state agriculture services shall be allowed.
- Planting Area Dimension
  - The following standards are minimum standards. All development is encouraged to provide street trees with the largest area of pervious surface and volume of soil that can be accommodated.
  - Trees shall be accommodated in planting areas that follow Metro Public Works' *Street Tree Standards and Specifications*.
  - The minimum pervious opening at grade shall be 24 square feet.
  - Tree vaults shall have the capability to drain water.
  - Planting areas shall not inhibit ingress/egress from buildings or pedestrian traffic along the Sidewalk Corridor.

## Section III: General Standards

### Building Materials: General Material Standards

All facade materials, exclusive of clear fenestration, shall be high quality and selected from the following list: masonry, masonry panels, textured metal, metal paneling, precast concrete, precast concrete panel, spandrel glass (on upper stories only), or materials substantially similar in form and function.

This requirement applies to any facade visible from a public street, open space, or interstate in all subdistricts. Alternative facade materials may be used if determined to be appropriate by the Planning Staff. Modifications may be permitted insofar as it is determined that these materials are necessary to further an established, overriding policy goal and will not significantly diminish the pedestrian experience.



Project: 16th and Chestnut, Denver. Source: <https://denverinfill.com>, Photo: Ryan Dravitz



Project: Addison and Clark, Chicago. Photo: SCB

## Section III: General Standards

### Parking and Access: General

---

#### Parking and Access: General

- No parking is required within the boundaries of the UDO.
- No onsite parking is allowed between the street and the building.

#### Parking and Access General Standards

- 17.20.050 Handicapped Parking, 17.20.060 Parking area design standards, and 17.20.130 Loading space requirements shall apply.

#### Valet and Drop-off areas

- They shall be located within the right of way when space allows. If not provided in the right of way, they shall be located internal to the development.
- Where driveways to parking facilities or drop off areas cross the Sidewalk Corridor, priority should be given to the pedestrian realm and the following shall be required:
  - The UDO and the MCSP sidewalks and tree planting standards shall be maintained for any pedestrian island that is created.
  - Bollards or other devices shall be used to separate the pedestrian and vehicular areas.
  - Distinction behind vehicular lane and pedestrian areas shall be indicated through changes in grade, color, texture and/or material.
- Curbside management plans are required. Consolidation of drop-off locations to a single location for multiple properties is highly recommended.

#### Stormwater

- Utilize LDI strategies in Metro Water Services Stormwater BMPs for hardscape, including parking and drive lanes.
- Prior to Final Site Plan approval, projects must demonstrate stormwater and flood mitigation design, and floodplain management.

## Section III: General Standards

### Parking and Access: Specific to Structured Parking

---

#### Vehicular Access

- Vehicular openings to parking structures shall not exceed thirty-five feet in width.
- Vehicular openings shall have a minimum spacing of thirty five feet.

#### Pedestrian Access

- All parking structures shall have a clearly marked pedestrian entrance, separate from vehicular access, on street frontages. A publicly accessible building lobby may meet this requirement.

#### Location and Lining

- On the ground level, parking structures shall be located behind a liner building with an active use that is a minimum of 15 feet deep.
- Where no ground level liner is provided (due to modifications or other reasons), facade treatment/cladding shall be required on all street, open space, and pedestrian ways. Cladding shall help to activate the street level with its design cues that integrate with the architectural characteristics of the habitable portion of the building, and of the surrounding built context. Openings for natural ventilation are permissible when well integrated into the facade design.
- Upper level habitable liners are encouraged on all streets. See the Bonus Height Program for more information on bonuses for Upper Level Garage Liners.
- Upper level facade treatments /cladding is required on all street, open space and pedestrian ways (such as greenways frontages, including any portions of facades visible from a given frontage, including interstate frontages. Facade treatments shall integrate or complement the architectural characteristics of the habitable portion of the building and the surrounding built context. Openings for natural ventilation are permissible when integrated into the facade design. Landscape buffering may be considered as an alternative at appropriate locations, such as interstate frontages.
- Underground parking that is visible from the street, shall not extend beyond the façade of the building unless it is screened. Underground parking that is completely below grade may extend beyond the façade of the building. Underground parking may not encroach into the right-of-way.

## Section III: General Standards

### Parking and Access: Specific to Surface Parking

#### General Standards for Surface Parking

- Parking area screening and landscaping standards shall apply to all surface parking lots including, but not limited to, public and private parking facilities, driveways and access aisles, the outdoor display of automobiles and other vehicles that are for sale or lease.
- Surface parking is best suited at the side or rear of a building, leaving the building frontage facing the circulation route.

#### Perimeter Screening Standards for Surface Parking

- Parking areas adjacent to public streets and open space shall be separated from the edge of the right-of-way and/or easements and property lines by a perimeter landscape strip a minimum of five feet in width which shall be landscaped per the standards of this section.
  - All perimeter landscape strips adjacent to public streets and open space shall include a transparent fence or knee wall in accordance with the Fence and Wall Standards.
- Parking areas shall be separated from adjacent side lot lines (with the exception of cross-access points) by a perimeter landscape strip a minimum of 5 feet in width, which shall be landscaped per the standards of this section.
  - A two and one-half foot landscape strip may be provided if the required trees are to be planted in tree islands located adjacent to the property line.
  - Two adjacent properties may share equally in the establishment of a 5 foot (minimum) planting strip along the common property line. In instances where the common perimeter planting strip is part of a plan for shared access, each owner may count the respective area contributed toward that common planting strip toward the interior planting area requirements for the lot. Conversely, a shared parking lot across property lines may be developed with no side lot perimeter planting strip, dependent upon the design and functional use of the space.
- Surface Parking Lots shall provide cross-access to all adjacent development and parking lots.

#### Interior Planting Requirements

- Parking areas shall be landscaped in accordance with the interior planting requirements of Title 17.24.160.
- Parking areas with less than twelve thousand square feet in total area shall be exempt from the interior and side lot line planting requirements.

#### Landscape Materials

- Perimeter landscape strips along public streets, open space and side lot lines:
  - Trees shall be installed at a rate of one tree for every thirty feet of frontage. Spacing may be adjusted with the approval of the Urban Forester based upon tree species, the presence of utilities, and the dimensions of the planting strip.
  - Evergreen shrubs and trees shall be installed at appropriate spacing to fully screen vehicles to a minimum height of two and one-half feet.
  - Plantings within fifteen feet of driveways or street intersections shall be maintained to a maximum height of two and one-half feet.
  - Plantings shall not obstruct views onto site as to impede the security of users.
- Tree and shrub species shall be chosen from the Urban Forestry Recommended and Prohibited Tree and Shrub List or an alternative species deemed appropriate by the Urban Forester.
- At planting, trees shall be a minimum of six feet in height and two caliper inches.
- All landscaping shall be in a functioning bio-swale, or irrigated using drip irrigation or sub-surface irrigation. If drought-tolerant species are used, no irrigation is required.
- At planting, all landscaping shall meet the standards for size, form and quality set out in the American Standard for Nursery Stock (ANSI Z60.1, latest edition).
- All nursery stock shall be vigorous, healthy and free of diseases or infestation.



# Section III: General Standards

## Parking Garage: Structure Height Regulation

The ratio of parking garage and base height to the overall building height is an important aspect of the visual appeal and balance of a structure. In order to encourage well proportioned buildings, the ratio of total heights of parking levels to total height of building program levels shall be regulated.

### Building Ratio

#### Ratio of Garage to Building Height

Parking garage to program ratio 1 garage : 3 levels

Parking garage height must comply with program to building height ratio. Heights shall be measured from the finished floor to the top of parapet of each program. Ground floor height is excluded from this calculation.

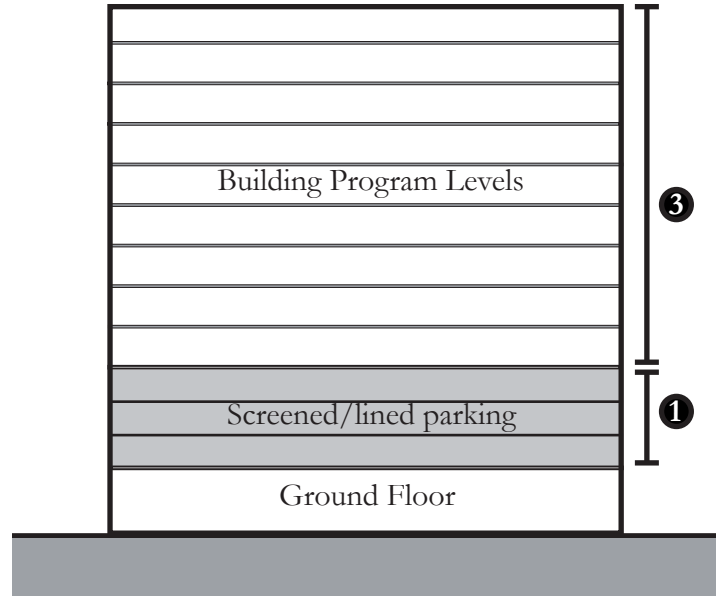

Height ratio schematic

# Section III: General Standards

## Parking Garage Treatment

All parking garage facades visible from a public street, open space, or interstate in all subdistricts are required to be visually shielded. Visual shielding may be achieved by the parking garage levels being below grade, lined with program, or clad according to the standards of this document. Alternative facade shielding methods may be used if determined to be appropriate by the Planning Staff. Modifications may be permitted insofar as it is determined that these methods are necessary to further an established, overriding policy goal and will not significantly diminish the pedestrian experience

## Cladding

If cladding is the determined approach, one or a combination of three cladding strategies shall be used on all facades requiring cladding: Screening, Solid Wall, or Innovative Design

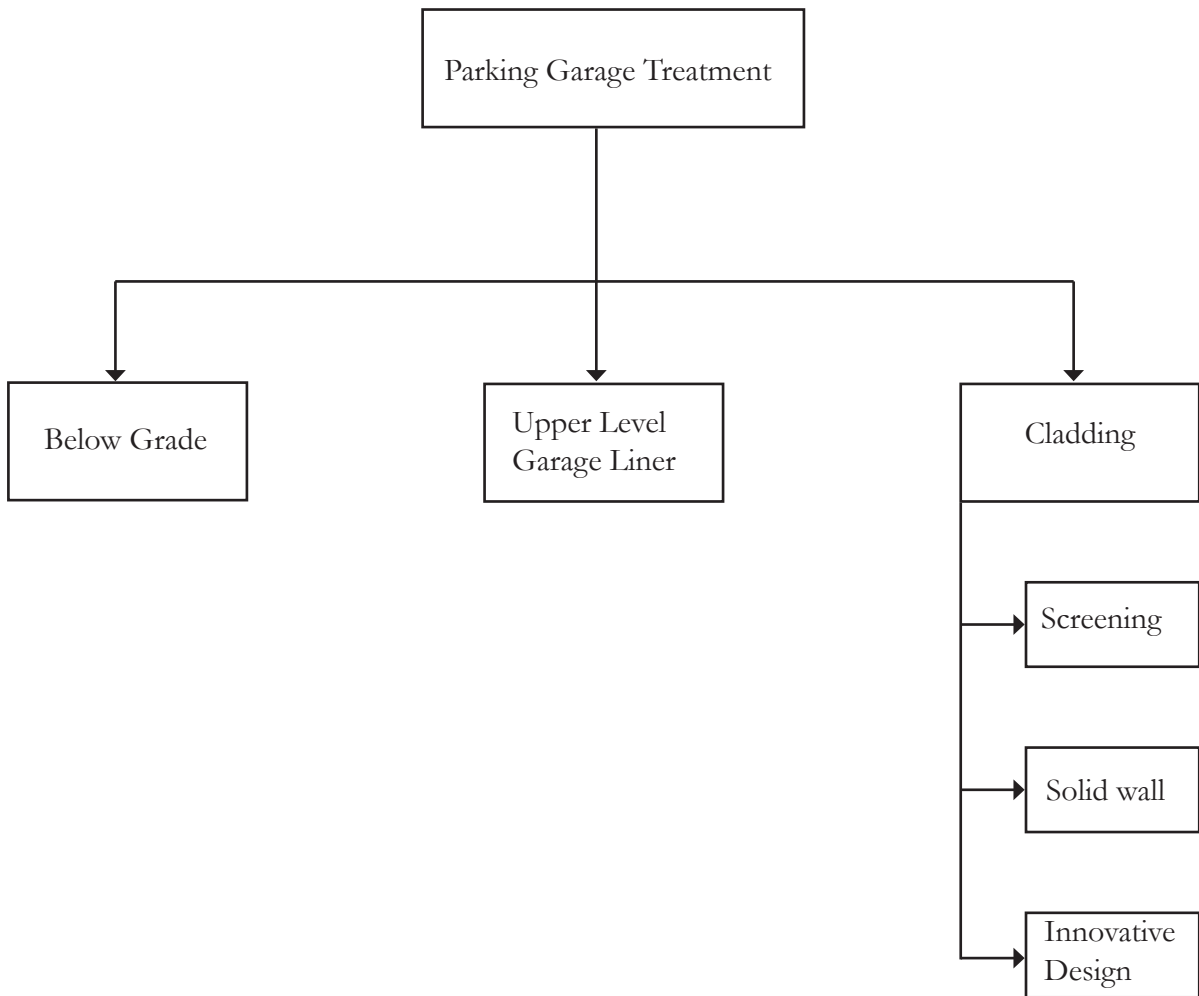

## Section III: General Standards

### Upper Level Garage Liner

- A liner program use requirement shall mean a habitable space occupied by retail, office, residential, institutional, cultural, commercial or recreational uses, specifically excluding parking, and mechanical uses. Minimum 15 feet in depth.
- To count as a lined garage, buildings must have liner program on the Principal frontage. If a building has multiple street frontages, all Primary street frontages shall have liner program. Other frontages shall comply with garage screening standards.
- Minimum glazing requirements shall apply to building program liners.



Project: Twelve | Twelve, Nashville. Source: twelvetwelve.com

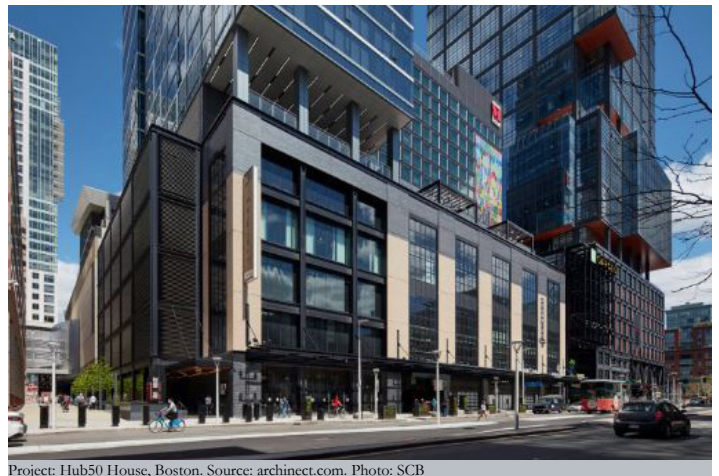

Project: Hub50 House, Boston. Source: architect.com. Photo: SCB



Project: 5th and Broadway, Nashville. Source: www.usa.skanska.com. Photo: Zack Benson

## Section II: General Standards

### Parking Garage Cladding: Screening

**Description:** A dynamic pattern of perforations, elements placed as angled panels, or louvers strategically arranged to blend functionality with aesthetic appeal. Crafted from durable materials ensuring longevity and resistance to environmental elements.

**Material suggestions:**

Perforated screens: Aluminium perforated plate panel systems, aluminium eggcrate grille systems, expanded mesh systems, extruded cassette screens, high tension mesh screens, aluminium corrugated-perforated plate systems

Louvers: Alluminium alloy, galvanized or stainless steel, wood or aluminium composite, reinforced fiberglass, transparent or translucent polycarbonate, corten steel.

Masonry: Brick or concrete blocks (in running, stack, flemish, english, basket weave bonds), stone veneer, architectural concrete panels

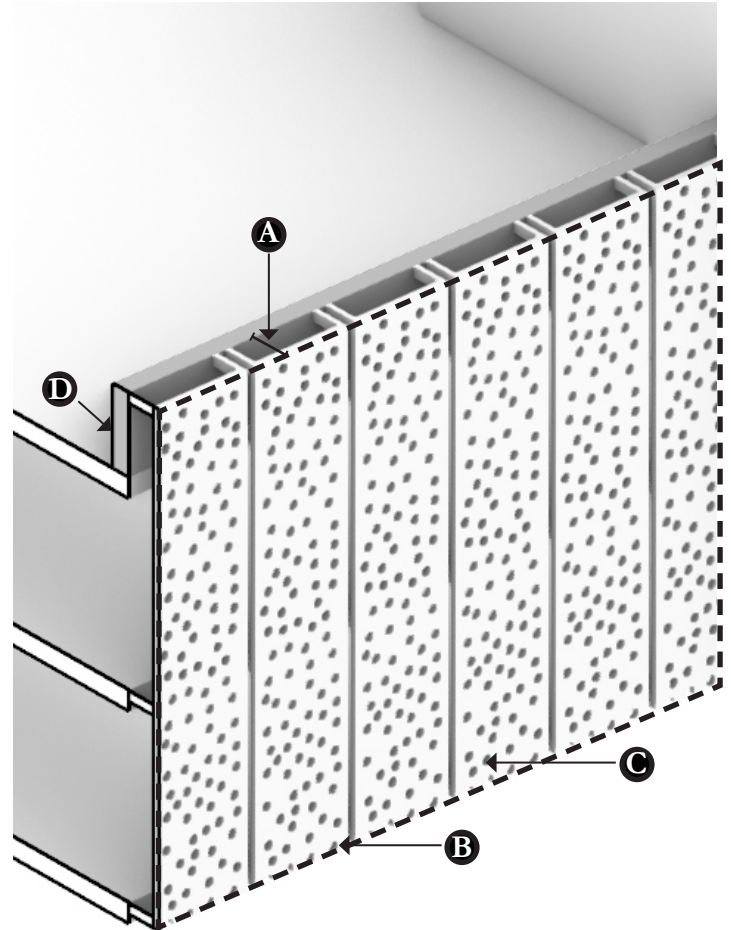

Garage Isometric Section

- A** Screening elements should have a gap of no more than 18” from the outer face of the screen element to the wall.
- B** Screening elements should be interspersed with minimum 60% opaque screening elements across the entire garage facade to block interior light from illuminating the surroundings at night.
- C** Screening elements should not have individual openings greater than 4 square inches to allow for adequate visual obscuring.
- D** Elements shall be located on the garage exterior, cover the floor of each parking deck and extend no less than three feet above floor finish level of the top floor of the garage.
- E** Screening and solid wall strategies may be mixed across a garage frontage to achieve appropriate parking garage treatment compliance.
- F** Screening and garage facade design should maintain appropriate relationship to building design and should be maintained in good condition at all times.

# Section III: General Standards

## Parking Garage Cladding: Screening



Project: A'eo Tower, Honolulu. Source: www.wardvillage.com



Project: 633 SE 3rd Ave, Ft Lauderdale. Source: oda-architecture.com

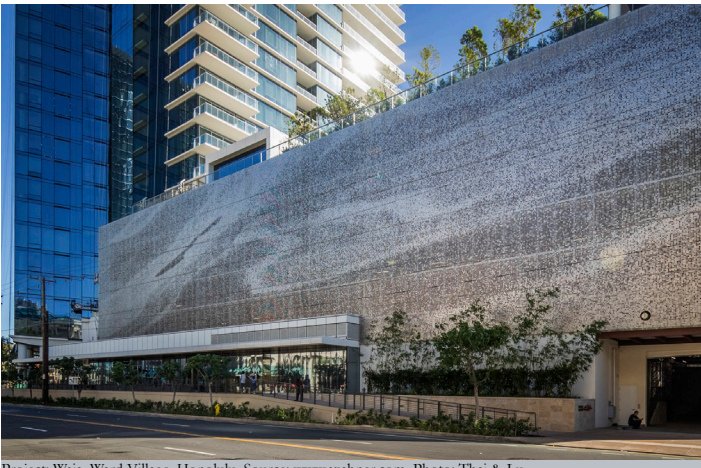

Project: Waia, Ward Village, Honolulu. Source: www.azahner.com. Photo: Thai & Lu

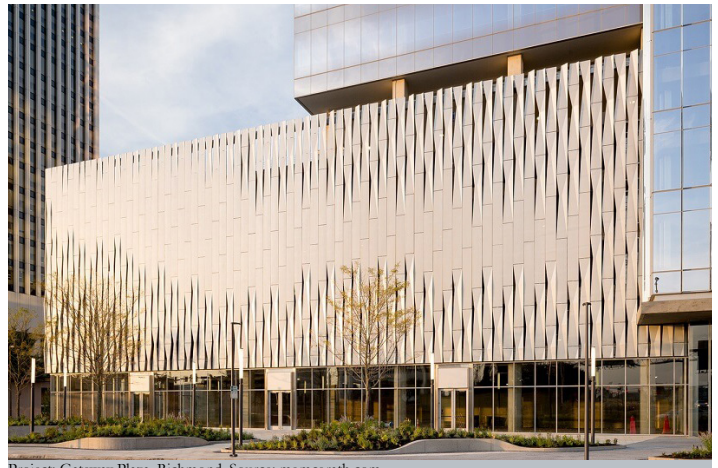

Project: Gateway Plaza, Richmond. Source: mgmegrath.com



Project: 360 N Green St, Chicago. Source: chicago.curbed.com. Photo: Gensler



Project: 333 N Green St, Chicago. Source: chicago.curbed.com. Photo: Gensler

## Section II: General Standards

### Parking Garage Cladding: Solid Wall

**Description:** A robust solution crafted from durable and weather-resistant materials designed for resilience against environmental elements for a long duration of time. It offers an opportunity for architectural expression by incorporating patterns, reliefs, or artistic elements while balancing privacy, security and perforation of natural light into the parking structure

#### Material suggestions:

Opaque: Brick or concrete blocks (in running, stack, Flemish, English, basket weave bonds), stone veneer, architectural concrete panels, stucco

Transparent: Sandblasted opaque spandrel glass, tinted glass (60% transmission)

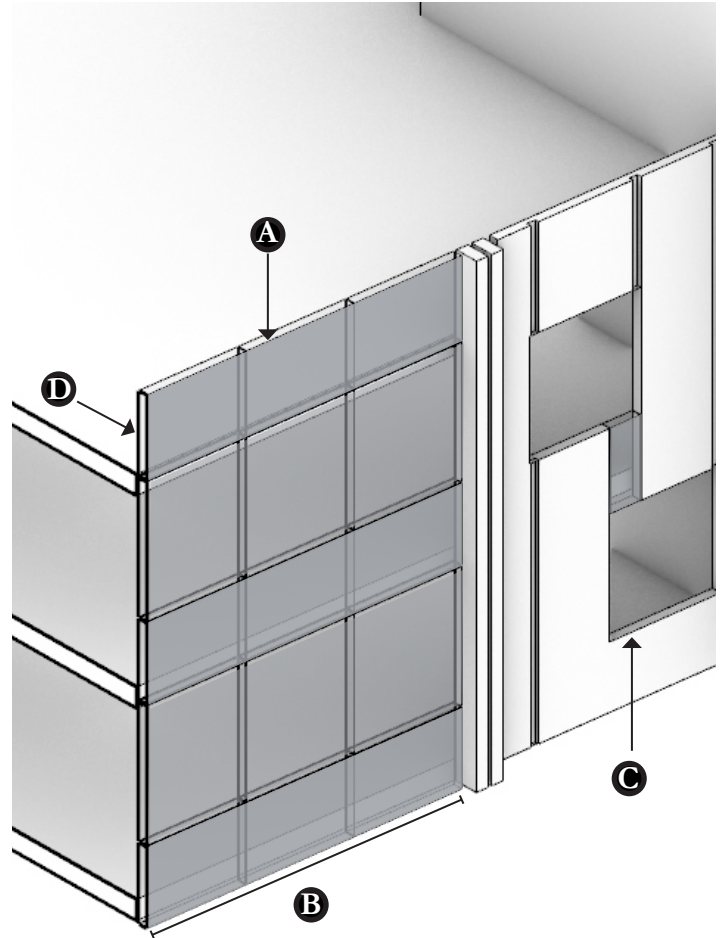

Garage Isometric Section

- A** Screening elements should have a gap of no more than 18" from the outer face of the screen element to the wall.
- B** Screening elements beyond 60' continuous length should be interspersed with different patterns and articulation strategies.
- C** Openings in exterior walls must be no more than 20% of total garage facade area and no individual opening shall exceed 36 square feet in size.
- D** Screening measures, including rooftop parapets, should be semi-opaque (minimum 60% transmission) up to 4 feet in height from each garage finish floor level.
- E** Screening and solid wall strategies may be mixed across a garage frontage to achieve appropriate parking garage treatment compliance. Opening compliance shall be measured in relationship to solid wall areas.
- F** Design should maintain appropriate relationship to building design and should be maintained in good condition at all times.

# Section III: General Standards

## Parking Garage Cladding: Solid Wall



## Section II: General Standards

### Garage Treatment: Innovative Design

**Description:** Allows for incorporation of unconventional features that complement both the design of the building and the surrounding while introducing new typologies of materials, scale, or style. Alternative screening methods or materials that do not meet screening or solid wall standards may be used following approval by the Planning Staff or its designee, provided that they are determined to be comparable to screening methods described in this subsection or display exceptional design, not limited to unique architecture, innovative use of materials, improvement of the project's relationship to surrounding properties or improvement to the character of the neighborhood.



Project: Mountain Dwellings, Copenhagen. Source: [www.archdaily.com](http://www.archdaily.com). Photo: Maria Gonzales

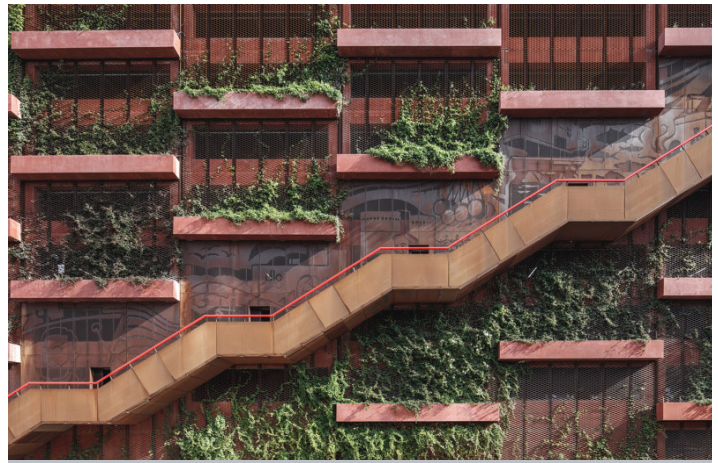

Project: Park 'n' Play, Copenhagen. Source: [www.archdaily.com](http://www.archdaily.com). Photo: Rasmus Hjortshøj - COAST



Project: Wynwood Garage, Miami. Source: [www.azahner.com](http://www.azahner.com). Photo: Tex Jernigan



## Section III: General Standards

### Garage Treatment: Lighting

**Description:** Parking garage lighting standards are to be designed to conform to Illuminating Engineering Society of North America (IESNA) requirements, to the Nashville Dark-Sky Association recommendations, and to the following criteria:

#### Recommendations:

- Glare control: Lighting adjacent to buildings and/or residential districts must be arranged so that luminaires have sharp cutoff at no greater than 78 degrees vertical angle above nadir. Not more than 5% of the total lamp lumens can project above 78 degree vertical
- Rooftop lighting is best set back 15' from the exterior perimeter wall and at a maximum height of 12-16' from floor finish level with cutoff light fixtures that have a maximum 90-degree illumination
- Outdoor lighting should be located, screened, shielded so that abutting lots with residential developments are not directly illuminated, the design should reduce glare to not impair the vision of motorists
- Motion activated lighting that dims when no activity is detected can be explored to increase energy efficiency
- Any internal illumination in which light fixtures are directly visible from the exterior is best directed internally upward or should contain shielded internal light fixtures



Project: Center street parking garage, Berkeley. Source: wonglogan.com. Photo: Marcy Wong

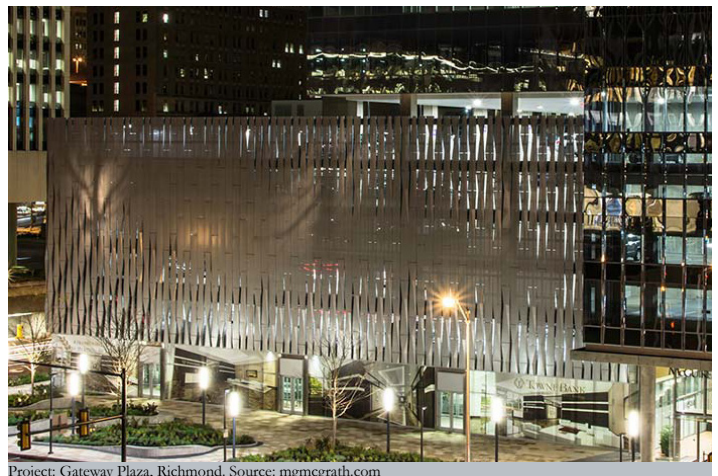

Project: Gateway Plaza, Richmond. Source: mgmcmgrath.com

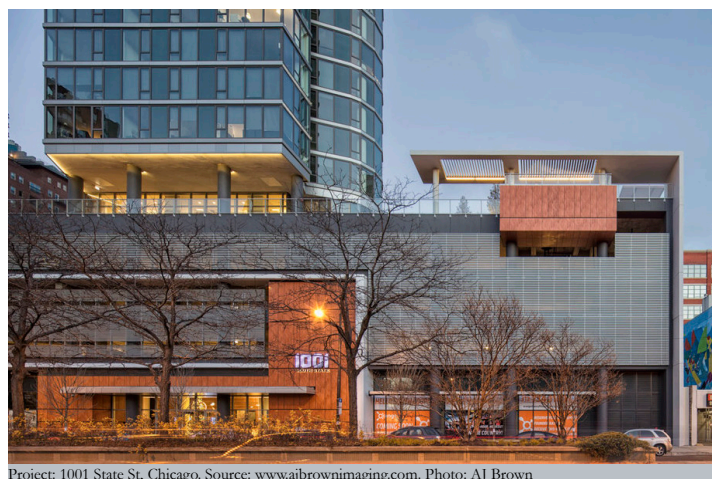

Project: 1001 State St, Chicago. Source: www.ajbrownimaging.com. Photo: AJ Brown

## Section III: General Standards

### Mechanical, Service, and Loading

---

#### Applicability

The following elements shall be shielded from view from adjacent public streets, pedestrian corridors, and open spaces.

- Refuse collection, dumpsters, recycling bins, and refuse handling areas that accommodate a dumpster or five or more trash or recycling cans.
- Building or ground-mounted mechanical equipment, including, but not limited, to transformers, back-flow preventors, telephone risers, equipment cabinets, generators, or similar devices.
- Mechanical equipment on roofs shall be fully screened.
- Air conditioning or similar HVAC equipment.
- Loading docks, berths, or similar spaces including, but not limited to, service entrances and maintenance areas.
- Outdoor storage of materials, equipment, and vehicles.

#### Location and Access

- Applicable site elements shall be located along the alley, along an interior property line, or internal to the property.
- Service elements, such as loading docks and trash collection locations, shall not be accessible from Primary Streets unless a Primary Street is the only frontage.
- Vehicular or service bay openings shall make up no more than 20% of the total frontage length along Primary Streets, Secondary Streets, or Open Space frontages.
- Where access to loading areas and service elements cross the Sidewalk Corridor, priority shall be given to the pedestrian realm and the following design elements shall be required:
  - The MCSP sidewalks and streetscape standards shall be maintained for any pedestrian islands or indentations created.
  - Bollards or other protective device shall be used to separate pedestrian and vehicular areas.
  - Distinction between vehicular lane and pedestrian areas shall be indicated through changes in grade, color, texture and/or material.

#### Screening Standards

- Applicable site elements shall be fully screened at all times.
- Refuse collection and refuse handling areas shall be screened by a walled enclosure with gates in accordance with the Fence and Wall Standards of the UDO.

## Section III: General Standards

### Mechanical, Service, and Loading

---

#### Screening Methods

- Vegetative Materials:
    - Vegetative materials shall be planted in two rows in staggered fashion.
    - All trees shall be evergreen with a minimum height at time of planting of at least six feet above the root ball.
    - All shrubs shall be evergreen with the minimum height and spacing necessary to fully screen the item intended for screening (but no less than thirty inches in height) at the time of planting.
    - Vegetative material shall be located immediately adjacent to the element being screened in a planting area a minimum of four feet wide.
  - Fencing and Walls
    - Screening is permitted through the use of a fence or wall constructed in accordance with the Fences and Walls Standards of the River North UDO.
  - Mechanical Penthouse
    - Rooftop mechanical areas must be fully visually screened.
    - Penthouse height limited to 20’.
    - Penthouse must be setback from the edge of the building roof below, by a distance equal to the penthouse height (1:1)
    - Penthouse walls and design shall minimize its visual impact, and be otherwise complementary to the building’s architecture and design.
    - Habitable space is not permitted.
  - Parapet Walls
    - Parapet walls or other techniques included as an integral part of the building design shall be used to totally screen any rooftop mechanical equipment from view from adjacent public rights-of-way or open space.
  - Integrated Building Elements or Features
    - Building design or other structural features (e.g, knee walls, alcoves, wing walls, roof extensions, etc.) may also be used to fully or partially enclose site features required to be screened.
  - Alternative Screening Methods
    - Alternative screening methods or materials that are not listed may be used following approval by the Planning Commission or its designee, provided that they are determined to be comparable to screening methods described in this subsection.
- \*\* In order to properly locate and screen mechanical equipment, approval may be required from applicable Metro departments and agencies.

## Section III: General Standards

### Fences and Walls

#### Location

- Permitted Locations: Fences and walls constructed in accordance with the standards in this section may be constructed within:
  - The Build-to Zone.
  - A utility easement only through the express written consent from the utility or entity holding the easement.
  - A required landscape area, Tree Protection Zone, or open space.
- Prohibited Locations: No fence or wall shall be installed that:
  - Encroaches into a right-of-way (without approval through the Mandatory Referral process).
  - Blocks or diverts a natural drainage flow on to or off of any other land.
  - Compromises safety by blocking vision at street intersections or obstructs the visibility of vehicles entering or leaving driveways or alleys.
  - Blocks access to any above ground or pad-mounted electrical transformer, equipment vault, fire hydrant or similar device.

#### Appearance

- All fences shall be installed so that the finished side shall face outward; all bracing shall be on the inside of the fence.
- Fences and walls shall be constructed of any combination of brick, stone, masonry materials, treated wood posts and planks, rot-resistant wood, metal, and wear resistant nonglossy plastics and recycled materials. Chain link fencing shall be coated with dark colored vinyl when visible from a public street or open space (excluding alleys).
- Chain-link fences are prohibited along street and open space frontages (including along greenways or multi-use trails).
- Razor wire is prohibited.
- Fences and walls used to screen refuse areas shall be opaque and include gates that prohibit unauthorized users to access the area.

#### Standards by function and location

- Fences and walls within the Build-to Zone shall not exceed four feet in height.
  - Modifications may be made in order to properly secure playgrounds and parks.
  - The height of fences and walls along a sidewalk shall be measure from sidewalk grade.
- Fences and walls within the Build-to Zone that are greater than three feet high shall be a minimum of thirty percent transparent to allow visibility into the property.
- Fences and walls used to screen parking shall be a minimum of two and one-half feet above the grade of the parking lot.
  - When a fence or wall is combined with plantings the majority of the plantings shall be between the right-of-way and the fence or wall.
- Fences and walls used to screen mechanical, loading and refuse elements shall be a minimum of two feet taller than the element being screened.
- All other fences and walls shall have a maximum height of ten feet measured from grade.
- Fences surrounding athletic fields and courts may exceed the previous height.

# Section III: General Standards

## Open Space Plan

The design of River North accommodates a variety of formal parks and open spaces as focal points within the community. The Open Space Plan depicts formal greens, squares, and linear parks that create publicly accessible settings for outdoor enjoyment. All of these spaces will be linked by a network of sidewalks, multi-purpose paths, walkable lanes, and bikeways, allowing continuous, non-motorized movement throughout the site, through a sequence of quality open-air environments that ultimately lead to the Cumberland River or a proposed “Central Park” within the center of the neighborhood. Buildings, streets, and parcels should generally be oriented toward open spaces to encourage safe interactive use.

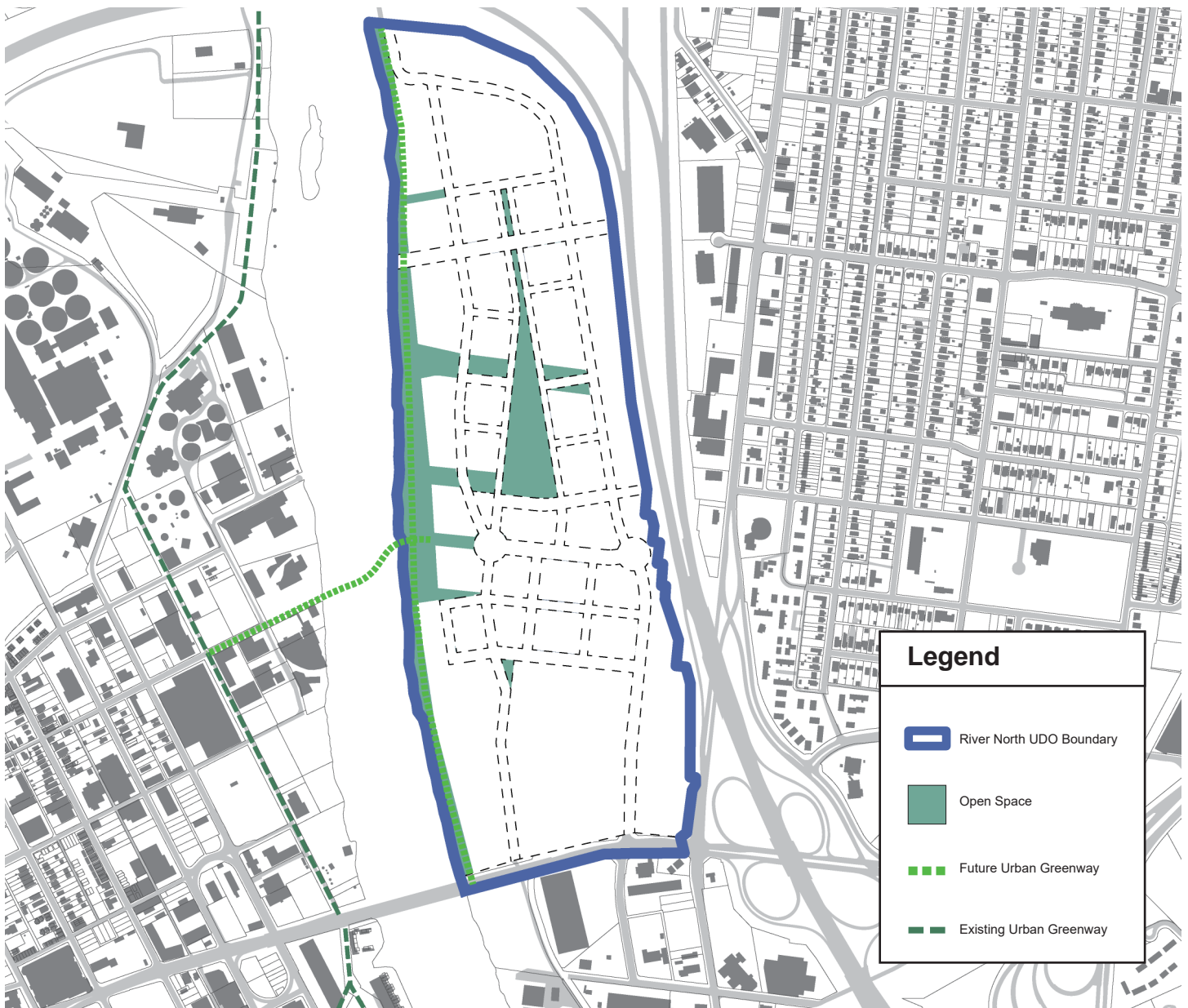

Open Space Plan

# Section III: General Standards

## Open Space: General Standards

---

### Open Spaces

Actual detailed plans, design, and locations of River North open spaces, parks, greenways, and green connections may vary, subject to constraints and conditions as yet to be determined. However, all proposed open spaces and/or alternatives must be consistent with the intent of the Open Space Plan and UDO.

### “Central Park”

A centrally located park, consisting of a minimum of two contiguous acres shall be located within the UDO boundary. The park space shall allow for public gathering and recreation, with activated uses along its edges.

### Riverfront Greenway

A north-south greenway with a linear park space will be provided along the riverfront of the Cumberland River. Recreation opportunities, outdoor dining, overlooks, wayfinding, and other interactive programming are appropriate components.

### Green Connections

Green connections will link the riverfront greenway and linear park space to the internal open space network and “Central Park” of the larger UDO area. Such connections may serve multiple purposes, but shall facilitate the movement of pedestrians through the open spaces of the UDO.

Modifications may be made in order to properly secure Standards of Title 17 not varied by the following Open Space Standards shall apply within the UDO.

### Access

- Every open space shall have a minimum of one primary pedestrian entrance along each street frontage and pedestrian frontage.
- All publicly accessible open space shall meet the appropriate standards of the American’s with Disabilities Act.

### Paving Materials

- Asphalt may be approved by the Planning Commission or its designee for recreational jogging or bicycle paths only.

### Landscaping

- Planting areas shall not impede ingress/egress from buildings or pedestrian traffic.
- Tree and shrub species shall be chosen from the Urban Forestry Recommended and Prohibited Tree and Shrub List based on tree size and planting area provided or an alternative species deemed appropriate by the Urban Forester.

## Section III: General Standards

### Bonus Height Program

The Bonus Height Program allows additional building height in the River North UDO in exchange for contribution to specified programs that provide benefits to the public. The additional building height shall be entitled if the proposed development contributes to specific public benefits in the amount and manner set forth herein.

#### Bonus Height Standards

- Upon providing a binding commitment for the specified public benefit, the proposed development project shall be allowed to build within the restrictions of the Subdistrict, up to the Bonus Height Maximum as established within this section.
- Multiple height bonuses may be compounded insofar as the total additional height does not exceed the Bonus Height Maximum for the Subdistrict.
- Additional development rights achieved through the BHP may be transferred to other sites within the UDO, one time to one receiving site, provided the transferred height does not exceed the Bonus Height Maximum of the receiving site. By right height may not be transferred; only bonus height received through the BHP may be transferred.
- Bonus height transfers shall be based on the square footage of the sending site, not the receiving site.
- No building permit shall be issued for bonus height until the Planning Commission has certified compliance with the provisions of this section, upon referral and assurance of compliance from applicable departments.

#### Bonus Height Chart

Subdistrict	One	Two
Subdistrict Height	15 stories	25 stories
<b>BONUSES</b>		
LEED Building	Silver = 1 story; Gold = 1 story; Platinum = 2 stories	Silver = 2 stories; Gold = 2 stories; Platinum = 3 stories
LEED ND	2 stories	2 stories
Pervious Surface	1 story	2 stories
Upper Level Garage Liner	1 story	4 stories
Underground Parking	1 story	3 stories
Public Parking	No Bonus	2 stories
Adaptable Garage Levels	2 stories	8 stories
Shared Parking	No Bonus	1 story
Civil Support Space	1 story	2 stories
Public Open Space	2 stories	8 stories
Public Greenway	2 stories	4 stories
Inclusionary Housing	3 stories	10 stories
<b>Maximum Bonus Height</b>	<b>18 stories</b>	<b>38 stories</b>

## Section III: General Standards

### Bonus Height Program

#### LEED and LEED ND

The U.S. Green Building Council (USGBC) is a non-profit organization that oversees the Leadership in Energy and Environmental Design (LEED) Green Building Rating System.

LEED for Neighborhood Development integrates the principles of smart growth, urbanism and green building into the first national system for neighborhood design. LEED ND goes beyond the building to address sustainability on a neighborhood-wide basis.

The bonuses are specific to each Subdistrict. See the BHP Chart for details.

A different nationally-recognized, third-party system of overseeing green building and/or sustainable development practices may be substituted for LEED. Bonuses will be determined by the Planning Commission based on ratings equivalent to LEED silver, gold, and platinum.

Bonuses for individual buildings are given upon pre-certification of LEED silver, gold and platinum. Bonuses for neighborhoods are given upon pre-certification of LEED ND. Every property within the LEED ND neighborhood may utilize the bonus height. The bonuses are specific to each Subdistrict. See the BHP Chart for details.

The following shall apply to all new construction that utilizes the Bonus Height Program for LEED:

- Prior to issuance of a temporary certificate of occupancy for any use of the development, a report shall be provided for the review of the Department of Codes Administration and the Planning Commission by a LEED accredited professional. The report shall certify that all construction practices and building materials used in the construction are in compliance with the LEED certified plans and shall report on the likelihood of certification. If certification appears likely, temporary certificates of occupancy (as set forth below) may be issued. Monthly reports shall be provided as to the status of certification and the steps being taken to achieve certification. Once certification is achieved, the initial certificate of LEED compliance, as set forth herein, and a final certificate of occupancy (assuming all other applicable conditions are satisfied) shall be issued.
- To ensure that LEED certification is attained the Department of Codes Administration is authorized to issue a temporary certificate of occupancy once the building is otherwise completed for occupancy and prior to attainment of LEED certification. A temporary certificate of occupancy shall be for a period not to exceed three (3) months (with a maximum of two extensions) to allow necessary time to achieve final certification. Fees for the temporary certificate (and a maximum of two extensions) shall be \$100 or as may otherwise be set by the Metro Council. Once two extensions of the temporary certificate of occupancy are granted, any additional extensions shall be granted only in conjunction with a valid certificate of LEED noncompliance as set forth herein.
- If the property fails to achieve LEED certification, the Department of Codes Administration is authorized to issue a short-term certificate of LEED noncompliance. This certificate will allow the building to retain its certificate of occupancy pending attainment of LEED certification. A certificate of LEED noncompliance shall be for a period not to exceed three (3) months and may be renewed as necessary to achieve certification. The fee for noncompliance shall be issued every time the certificate is issued for up to ten years.
- The fee for a certificate of LEED noncompliance shall be based on the following formula:  $F = [(CN-CE)/CN] \times CV \times 0.0075$ , where:
  - F is the fee;
  - CN is the minimum number of credits to earn the level of LEED certification for which the project was pre-certified;
  - CE is the number of credits earned as documented by the report; and
  - CV is the Construction Value as set forth on the building permit for the structure.



## Section III: General Standards

### Bonus Height Program

---

#### Pervious Surface

The integration of pervious surfaces into site design and building design benefits the individual development, the neighborhood and the city. Pervious surfaces can reduce stormwater runoff, flood risk, irrigation needs and the burden on infrastructure. Examples of pervious surfaces include pervious pavement, green roofs, bio-swales, landscaping, and green screens. As technology in this field advances, additional pervious surfaces may meet the intent of this standard.

- The number of square feet of Bonus Height shall be twice that of the number of square feet of Pervious Surface. The additional square footage may be used to the Bonus Height Maximum as determined on the BHP Chart.
- Green roofs that are utilized to meet LEED certification may not be “double counted” for both the LEED height bonus and the Pervious Surface height bonus. If the level of LEED certification would be met without the green roof, then the green roof may be counted for the Pervious Surface height bonus.
- Pervious Surfaces may not be double counted if used towards the Public Open Space or Public Greenway Bonuses.

#### Upper Level Garage Liner

The public realm of the streetscape is improved by lining above ground parking structures with habitable space. See the BHP Chart for a list of Subdistricts in which the Upper Level Garage Liner bonus may be utilized.

- Height bonuses are given for upper levels of habitable space, a minimum of 15' in depth, which masks a parking structure from view along streets or open space (including greenways and multi-use trails).
- The number of square feet of Bonus Height shall be twice that of the number of square feet in Garage Liners. The additional square footage may be used to the Bonus Height Maximum as determined on the BHP Chart.

#### Underground Parking

The public realm of the streetscape is improved by providing parking in underground structures. See the BHP Chart for a list of Subdistricts in which the Underground Parking bonus may be utilized.

- The number of square feet of Bonus Height shall be equal to the number of square feet in Underground Parking. The additional square footage may be used to the Bonus Height Maximum as determined on the BHP Chart.
- Height bonuses are not given for ground level liners, or upper level liners that are required by the UDO.

#### Public Parking

Parking accessible to the general public is important to the continued growth and vitality of Downtown. See the BHP Chart for a list of Subdistricts in which the Public Parking bonuses may be utilized.

- The number of square feet of Bonus Height shall be twice that of the number of square feet in Public Parking. The additional square footage may be used to the Bonus Height Maximum as determined on the BHP Chart.
- Public Parking shall be clearly marked as public, and shall be accessible to the public, at all hours that the garage is open, for the lifetime of the building.

## Section III: General Standards

### Bonus Height Program

#### Adaptable Garage Levels

Parking Garages built to accommodate future uses, with a ceiling height of 11 feet or greater, are encouraged and desired. See the BHP Chart for a list of Subdistricts in which the Adaptable Garage Levels bonus may be utilized.

- The number of square feet of Bonus Height shall be twice that of the number of square feet in the Parking Garage, so long as the garage is designed with 11 foot high ceilings or greater and an Architect has provided a letter to Planning asserting that the garage can be easily converted to an alternative use if parking is no longer needed or desired. The additional square footage may be used to the Bonus Height Maximum as determined on the BHP Chart.
- Underground parking levels are not applicable for the Adaptable Garage Levels Bonus.

#### Shared Parking

Shared Parking provides opportunities for businesses and establishments to consolidate parking needs, thereby consuming less physical space to satisfy their joint parking demands. In addition, Shared Parking can consist of Park and Ride, or dedicated car-sharing spaces. See the BHP Chart for a list of Subdistricts in which the Shared Parking Bonus may be utilized:

- The number of square feet of Bonus Height shall be equal to twice the number of square feet in Shared Parking (including Park and Ride or car sharing lots). The additional square footage may be used to the Bonus Height Maximum as determined on the BHP Chart.
- Shared Parking must demonstrate that the parking results in less parking spaces than would typically be provided as individual allocations.
- Parking agreements must be recorded and remain in place for the lifetime of the buildings.
- Park and Ride and car sharing options must demonstrate acceptance by all applicable entities including Metro Departments.

#### Civil Support Space

The dedication of Civil Support Space offers height bonus for the developer's contribution of space to a specific use or entity that serves to better the neighborhood or community. See the BHP Chart for details for a list of Subdistricts in which the Civil Support Space bonus may be utilized.

- Civil Support Space is typically on the ground level. Upper levels may be appropriate depending on the intended use.
- The number of square feet of Bonus Height shall be twice that of the number of square feet donated to Civil Support Space. The additional square footage may be used to the Bonus Height Maximum as determined on the BHP Chart.
- Civil Support Space shall be dedicated to the chosen use or uses for 15 years. Adherence to this standard shall be checked yearly by the Planning Commission or its designee.

The Planning Commission may require the developer to execute an agreement, restrictive covenant, or other binding restriction on land use that preserves the use of Civil Support Space for the required period before final site plan review.

The following are examples appropriate for Civil Support Spaces:

- Institutional Uses
  - Cultural center
  - Day care center
  - School day care
- Education
  - Community education
- Transportation Uses
  - Transit Center
- Waste Management Uses
  - Recycling collection center
- Recreational, Civic, or Entertainment Uses
  - Community playground
- Other Uses
  - Community garden

Other uses may be appropriate for Civil Support Space. The applicant may propose a different use for Civil Support Space to be approved by the Executive Director.

## Section III: General Standards

### Bonus Height Program

---

#### Public Open Space

Open Space accessible to the general public is critical to the continued health and vitality of River North. See the BHP Chart for a list of Subdistricts in which the Public Open Space bonus may be utilized.

- The number of square feet of Bonus Height shall be seven times that of the number of square feet in Public Open Space. The additional square footage may be used or transferred to the Bonus Height Maximum as determined on the BHP Chart.
- Public Open Space may be provided on the property being developed, or on another property within the UDO. In the latter case, the derived bonus shall be transferred from the Open Space Site to the Development Site.
- Public Open Space shall be clearly marked as public, and shall be accessible to the public, at all hours that the open space is open, in perpetuity.
- In order to qualify for the bonus, all of the following requirements shall be met:
  - Minimum contiguous area of ¼ acre.
  - Accessible to the public through a secured public easement, dedication, or agreement with Metro Parks or a Metro approved third party trust.

#### Public Greenway

Greenways and multi-use paths serve a key dual function: to provide recreational enjoyment for River North, and to provide increased connectivity to destinations in East Nashville that provides a critical alternative mode of transportation for residents and visitors to navigate the surrounding area without the need of a car. See the BHP Chart for a list of Subdistricts in which the Public Greenway bonus may be utilized.

- The number of square feet of Bonus Height shall be 50 times that of the number of linear feet in Public Greenway / multi-use path dedicated. The additional square footage may be used to the Bonus Height Maximum as determined on the BHP Chart.
- Public Greenways requires the dedication of land to Metro (or acceptance of a permanent public easement) for the explicit use of Greenways/multi-use paths.
- In order to qualify for the bonus, all of the following requirements shall be met:
  - Accessible to the public through a secured public easement, dedication, or agreement with Metro Parks.
  - When feasible, pedestrian linkages shall be provided to adjacent neighborhoods and developments.
  - Proposed buildings abutting the Greenway or multiuse path shall include ground level active uses, with at least one direct pedestrian entrance.

#### Inclusionary Housing

- Bonus Height is available for compliance with Section 17.40.780 of the Zoning Code as shown in the Bonus Height Program Chart.

This page left intentionally blank

# Appendix:

OCTOBER 2017

# DEVELOPMENT CAPACITY EVALUATION STUDY

RIVER NORTH  
NASHVILLE, TENNESSEE

PREPARED FOR:  
MONROE INVESTMENT PARTNERS, LLC



1101 17<sup>TH</sup> AVENUE SOUTH  
NASHVILLE, TENNESSEE 37212

DEVELOPMENT CAPACITY EVALUATION STUDY  
RIVER NORTH  
NASHVILLE, TENNESSEE

PREPARED FOR:  
MONROE INVESTMENT PARTNERS, LLC



PREPARED BY:  
**KCI TECHNOLOGIES, INC**  
1101 17<sup>th</sup> Avenue South  
Nashville, TN 37212  
615.370.8410 office 615.370.8455 fax  
[www.kci.com](http://www.kci.com)

**TABLE OF CONTENTS**

1. INTRODUCTION ..... 1

2. PROJECT DESCRIPTION..... 3

3. EXISTING SETTING ..... 4

    3.1 Regional and Local Access ..... 4

    3.2 Existing Traffic Volumes..... 4

    3.3 Existing Traffic Operations..... 8

4. IMPACTS ..... 10

    4.1 Trip Generation..... 10

    4.2 Evaluation ..... 12

        4.2.1 Low Level and Medium Level Improvements ..... 12

        4.2.2 High-Level Improvements..... 18

        4.2.3 Cowan Street Cross-Section.....25

7. CONCLUSIONS AND RECOMMENDATIONS .....32



**LIST OF FIGURES**

FIGURE 1. LOCATION OF THE PROJECT SITE..... 3

FIGURE 2. EXISTING PEAK HOUR TRAFFIC VOLUMES..... 6

FIGURE 3. 2016 AADT DATA..... 7

FIGURE 4. DIRECTIONAL DISTRIBUTION OF TRAFFIC GENERATED BY THE PROJECT SITE UNDER LOW-LEVEL AND MEDIUM-LEVEL IMPROVEMENTS..... 14

FIGURE 5. LOW-LEVEL IMPROVEMENTS AT THE INTERSECTION OF JEFFERSON STREET AND COWAN STREET..... 16

FIGURE 6. MEDIUM-LEVEL IMPROVEMENTS AT THE INTERSECTION OF JEFFERSON STREET AND COWAN STREET..... 17

FIGURE 7. DIRECTIONAL DISTRIBUTION OF TRAFFIC GENERATED BY THE PROJECT SITE HIGH-LEVEL IMPROVEMENTS-OPTION 1 ..... 18

FIGURE 8. DIRECTIONAL DISTRIBUTION OF TRAFFIC GENERATED BY THE PROJECT SITE HIGH-LEVEL IMPROVEMENTS-OPTION 2.....20

FIGURE 9. DIRECTIONAL DISTRIBUTION OF TRAFFIC GENERATED BY THE PROJECT SITE HIGH-LEVEL IMPROVEMENTS-OPTION 3.....22

FIGURE 10. DIRECTIONAL DISTRIBUTION OF TRAFFIC GENERATED BY THE PROJECT SITE HIGH-LEVEL IMPROVEMENTS-OPTION 4.....24

FIGURE 11. TOTAL PROJECTED PEAK HOUR TRAFFIC VOLUMES (LOW-LEVEL IMPROVEMENTS).....27

FIGURE 12. TOTAL PROJECTED PEAK HOUR TRAFFIC VOLUMES (MEDIUM-LEVEL IMPROVEMENTS).....28

FIGURE 13. TOTAL PROJECTED PEAK HOUR TRAFFIC VOLUMES (HIGH-LEVEL IMPROVEMENTS-A).....29

FIGURE 14. TOTAL PROJECTED PEAK HOUR TRAFFIC VOLUMES (HIGH-LEVEL IMPROVEMENTS-B).....30

FIGURE 15. TOTAL PROJECTED PEAK HOUR TRAFFIC VOLUMES (HIGH-LEVEL IMPROVEMENTS-C) ..... 31

**LIST OF TABLES**

TABLE 1. PHASE 1 OF THE DEVELOPMENT PROGRAM ..... 3

TABLE 2. DESCRIPTIONS OF LEVEL OF SERVICE FOR SIGNALIZED INTERSECTIONS.... 8

TABLE 3. EXISTING AM PEAK HOUR LEVELS OF SERVICE ..... 9

TABLE 4. EXISTING PM PEAK HOUR LEVELS OF SERVICE ..... 9

TABLE 5. DEVELOPMENT TRIP GENERATION (PHASE 1) ..... 11

TABLE 6. MAXIMUM NEWLY GENERATED TRIPS BY THE PROPOSED DEVELOPMENT DURING PM PEAK HOUR UNDER LOW-LEVEL IMPROVEMENTS SCENARIO ..... 15

TABLE 7. MAXIMUM NEWLY GENERATED TRIPS BY THE PROPOSED DEVELOPMENT DURING PM PEAK HOUR UNDER MEDIUM-LEVEL IMPROVEMENTS SCENARIO ..... 15

TABLE 8. MAXIMUM NEWLY GENERATED TRIPS BY THE PROPOSED DEVELOPMENT DURING PM PEAK HOUR UNDER HIGH-LEVEL IMPROVEMENTS SCENARIO-OPTION 1 ..... 19

TABLE 9. MAXIMUM NEWLY GENERATED TRIPS BY THE PROPOSED DEVELOPMENT DURING PM PEAK HOUR UNDER HIGH-LEVEL IMPROVEMENTS SCENARIO-OPTION 2 ..... 21

TABLE 10. MAXIMUM NEWLY GENERATED TRIPS BY THE PROPOSED DEVELOPMENT DURING PM PEAK HOUR UNDER HIGH-LEVEL IMPROVEMENTS SCENARIO-OPTION 3 ..... 23

TABLE 11. MAXIMUM NEWLY GENERATED TRIPS BY THE PROPOSED DEVELOPMENT DURING PM PEAK HOUR UNDER HIGH-LEVEL IMPROVEMENTS SCENARIO-OPTION 4 ..... 25

## EXECUTIVE SUMMARY

### Project Description

The planned River North project proposes the development of approximately 125 acres on the east side of Cumberland River between Jefferson Street and I-24 and I-65 in downtown Nashville. This study evaluates the high-level impacts of the southern 40 acres of the development, which the study will refer to as Phase 1. The traffic analysis is based on more density than is currently contemplated by the developer. Given variables such as local demand and overall economy, it is prudent to underwrite conservatively.

Phase 1 of the development, as considered for this analysis, includes a total of approximately three (3) million square feet of office space, 1,735 residential units, 285,000 square feet of retail/restaurant space, 550 hotel rooms and 186,500 square feet of civic space. While Phase 1 consists of 40 acres and could take 15 years or more depending on economic cycles, and zoning permits significant density, it is anticipated that the entirety of the development will be completed in multiple phases that could take 30 years or more to complete.

The master plan proposes a variety of new roadway extensions, bridges, interchanges and access connections to the interstate system as well as to existing streets. Therefore, the purpose of this study is to evaluate the feasibility and desirability of these access improvements and to determine maximum newly generated traffic that can be managed under low, medium, and high levels of roadway improvements based on these evaluations. Finally, potential transportation strategies were explored and are recommended in order to achieve higher density for the proposed development by improving the overall local and regional mobility of the area.

### Data Collection

In order to provide data for the traffic impact analysis, manual traffic counts were conducted at the following intersections:

1. Jefferson Street/Spring Street and Cowan Street
2. Spring Street and North 1<sup>st</sup> Street
3. Spring Street and Dickerson Pike
4. I-24 On & Off-Ramps at Spring Street
5. I-24 Eastbound Off-ramp at North 1<sup>st</sup> Street

Traffic counts for the study intersections were conducted in June 2016 by KCI. Specifically, the turning movement counts were conducted from 7:00 – 9:00 AM and 4:00 – 6:00 PM on a typical weekday in June 2016. From the counts, it was determined that the peak hours of traffic flow for the study intersections occurred from 8:00 – 9:00 AM and 4:00 – 5:00 PM.

## Evaluations

Various combinations of the potential improvements within the study area were developed. Directional distributions of traffic generated by the proposed project were then established based on the proposed access connections under each scenario and the existing travel patterns developed from the existing peak hour traffic counts.

For the purpose of this study and based on the capacity analysis it was determined that the intersection of Jefferson Street/Spring Street and Cowan Street is the control intersection for the sensitivity analysis. In addition, the proposed development has higher impacts at that intersection during the PM peak hour when compared to the AM peak hour. As a result, for the sensitivity analysis, capacity analyses were conducted at the intersection of Jefferson Street/Spring Street and Cowan Street during the PM peak hour under each of the various scenarios. Finally, the maximum new trip-generated traffic volumes by the proposed development (based on the PM peak hour volumes) which can be accommodated under each scenario were presented.

## Conclusions and Recommendations

A review was conducted of the roadway extensions, bridges and interstate access connections that are proposed as part of the River North master plan. Sensitivity analyses were also conducted to estimate the maximum expected newly generated trips by the proposed development, which can be managed by implementing those conceptual improvements within different stages. The suggested improvements are categorized as Low Level, Medium Level, and High Level. Conclusions of the reviews and analyses are as follows:

- The Cleveland Street extension and a connection across I-24 make a significant connection to the East Nashville area and will provide access to Dickerson Pike, Whites Creek Pike, Ellington Parkway (US 31E) and Gallatin Pike. Cleveland Street has a four-lane cross-section from Dickerson Pike to east of Ellington Parkway. Utilizing the highest PM peak hour trip generation (Option 4B) and the associated distribution, the Cleveland Street extension has the potential to add approximately 1,000 PM peak hour trips along the corridor; this serves as a

significant increase over the 9,000 vpd currently served by the corridor. There are currently two (2) all-way stop controlled intersections along this portion of Cleveland Street, located at Meridian Street and Lischey Avenue. Improvements will likely be necessary at these intersections, at the Ellington Parkway ramps, and potentially at other intersections along the corridor when the Cleveland Street extension is constructed.

- Previous versions of the River North master plan included new on and off ramps to I-65 and I-24. Interchange modifications and/or new connections to the interstate system require both state and federal approval and there are strict standards regarding minimum spacing between ramps that must be met in order to obtain the necessary approvals. State and federal approval of any new interstate access is likely to require considerable modifications to the existing interchanges including the employment of one or more strategies to eliminate weaving on the interstate. These strategies include the addition of collector-distributor roads or grade separated ramps (ramp braids). Requirements for these type of freeway modifications are described in the NCHRP 687 report, *Guidelines for Ramp and Interchange Spacing*. Specific details regarding the operations and feasibility of any interchange modifications or additional access points will need to be evaluated more thoroughly before understanding the feasibility of such improvements.
- The two proposed bridges over the Cumberland River have the potential to significantly improve access and provide alternative routes that would help lessen the impact of the project on the interstate system and on Jefferson Street/Spring Street. The current master plan illustrates the northern bridge as a vehicular and multimodal bridge and the southern bridge as a pedestrian and bicycle only bridge. It would be desirable for at least one of the bridges to have significant transit carrying capabilities.
- Consideration should be given to connecting the northern Cumberland River bridge to 3<sup>rd</sup> Avenue as well to provide more accessibility to and from north Nashville.
- A potential connection to Oldham Street has been discussed during the development of the masterplan. This connection would create a new north/south connection for project related traffic that may relieve development related traffic at the intersection of Jefferson Street/Spring Street and Cowan Street. The effectiveness of this connection could be further supported by

improvements to South 1<sup>st</sup> Street, which provides access to Woodland Street to the south.

- The Grace Street extension and a connection across I-24 will provide a convenient connection to East Nashville and to Meridian Street, a north/south collector street. In addition, the Grace Street extension has the potential to be a strong bicycle/pedestrian connection to the pedestrian/bicycle bridge over Ellington Parkway. It should be noted that this proposed improvement was not included in the capacity analysis, for the purpose of this study. It was assumed that a portion of the distributed traffic on the Cleveland Street connector would be distributed onto the Grace Street extension, which would result in the same reduction of traffic on Jefferson Street/Spring Street as without the implementation of this improvement.
- As previously described, the maximum full buildout of the southern 40 acres of the development is referred to as Phase 1 in this study. Improvement recommendations at the existing intersection of Jefferson Street/Spring Street and Cowan Street associated with , Phase 1 of the development were also evaluated and are described below.
  - Add additional turning lanes at the intersection of Jefferson Street and Cowan Street such that southbound Cowan Street consists of two or three left-turn lanes, a shared through/right lane and a right-turn lane. Further, an additional westbound lane will enhance capacity at this intersection. A right-turn lane with sufficient storage is recommended on the eastbound approach of Jefferson Street as well. It may be necessary to widen the eastern portion of the Jefferson Street bridge in order to add the recommended eastbound lane along Jefferson Street. Other feasible alternatives which may not require the widening of the bridge in order to accommodate additional eastbound travel lane, should also be considered and analyzed.
- The results of capacity analyses indicated that with low-level roadway improvements within the study area as described in the evaluation section, approximately 22% of the newly generated Phase 1 trips can be accommodated by the study area roadway system. Maximizing the density within the River North development is best accommodated with the high-level roadway improvements described previously in this study. Those improvements include the proposed new connectors/bridges with partial movement accesses to I-24 and/or I-65, providing an additional eastbound travel lane on Jefferson Street

and the I-24 bridge over Spring Street, and additional turning lanes on Cowan Street at Jefferson Street/Spring Street. It is estimated that 133% of the PM peak hour (5,940 vehicles per hour) for Phase 1 can be accommodated by implementing those improvements.

- It should be noted that intersections along Jefferson Street/Spring Street within the study area currently operate at or near capacity levels during peak times. Therefore, improving the operational performance and traffic flow of Jefferson Street/Spring Street within the study area is warranted as of today even without the completion of any stages of River North development. Any development along the east bank is likely to exacerbate this existing need, and access and capacity improvements will be needed to provide adequate traffic operations within the study area .
- It should be noted that the thresholds of development identified in this study are based on trips that are projected to be generated by the development of the River North project. As the development of River North progresses, the land uses and sizes that are actually developed may be different than those assumed for this study. If this occurs, continuing to use PM peak hour trips as the warranting criteria for improvements will be an effective way to ensure that the recommended improvements are provided when needed.
- The evaluation of the proposed improvements and estimation of the maximum newly generated trips for the proposed development under each phase can be used as a helpful tool to plan different stages of the development. However, the capacity analysis procedure used in this study was based on several assumptions. It is recommended that the development conduct traffic counts as certain portions of the development is being completed and occupied in order to identify actual trip generation for the developed portions of the River North development. Those counts will provide a stronger foundation to verify the assumptions made in this study and also to explore further improvements using the actual travel patterns in and out of the development.
- It is important to note that traffic impact assumptions in this study are conservative, meaning analyses of network impacts were limited to the immediate vicinity of the development. Given the site's size and location adjacent to downtown and critical regional roadway junctions, impacts (positive or negative) will occur well beyond the site. Should more robust high-level improvements be constructed, such as additional bridge connections or interstate improvements, functionality of the greater network in this area may in fact improve. Neither TDOT nor Metro Nashville has significant infrastructure improvements planned for the near term in this area, and while new trips will

be added, these potential high-level improvements could provide alternative connections in the downtown area.

- Higher density for the proposed development may be achieved by emphasizing ride-share, and public transportation. Based on Mayor Barry's Transportation Action Agenda (Moving the Music City) plan, Metro Nashville, in partnership with TDOT, is developing a plan called Nashville Complete Trips. As part of the plan, Metro will promote other modes of transportation by reaching out to major employers and connecting employers and commuters to information about transportation options such as the transit and bikeshare systems, flex-scheduling and telecommuting, bike parking, and MTA/RTA park-and-ride locations. This plan would provide more opportunities for public-private partnerships by the proposed development. Such partnerships could be accomplished by providing private ride-share vehicles and/or sponsoring public transportation commutes for the employees. Upon the success of sponsoring other modes of commute, higher density for the proposed development could potentially be achieved with less traffic impacts on the roadway system.



## 1. INTRODUCTION

The purpose of this study is to evaluate the high-level traffic impacts associated with the southern 40 acres of the proposed River North development project, which the study will refer to as Phase 1, in Nashville, Tennessee. Specifically, a sensitivity analysis was conducted to estimate the maximum newly generated trips, which could be accommodated with the roadway network under various minor and major roadway improvements. The traffic analysis is based on more density than is currently contemplated by the developer. Given variables such as local demand and overall economy, it is prudent to underwrite conservatively.

The proposed 125-acre development will include a mix of land uses including office, retail, hotel, residential, and civic spaces. Currently, the plan for the Phase 1 of the development, as considered for this analysis, includes a total of approximately three (3) million square feet of office space, 1,735 residential units, 285,000 square feet of retail/restaurant space, 550 hotel rooms and 186,500 square feet of civic space. While Phase 1 consists of 40 acres and could take 15 years or more depending on economic cycles, and zoning permits significant density, it is anticipated that the entirety of the development will be completed in multiple phases that could take 30 years or more to complete.

The property is generally bound to the south by Jefferson Street, to the east by Interstate 24 (I-24), to the north by the Interstate 65 (I-65) northbound to I-24 eastbound ramp and on the west by the Cumberland River. Access to the development will be provided at multiple locations as indicated in the attached master plan (see Appendix).

The master plan proposes a variety of new roadway extensions, bridges, interchanges and access connections to the interstate system as well as to existing streets. Therefore, evaluations were conducted for the feasibility and desirability of these access improvements and based on these evaluations, maximum newly generated traffic that can be managed under low, medium, and high levels of roadways improvements were determined. Finally, potential transportation strategies were explored and are recommended in order to achieve higher density for the proposed development by improving the overall local and regional mobility of the area.

It should be noted that the purpose of this study is not to evaluate the traffic impacts associated with the proposed development at each individual intersection within the study area. Rather, this study intends to estimate the maximum new number

of vehicular trips that the whole roadway system in the study area can manage. To achieve that, a control intersection (Spring Street/Jefferson Street and Cowan Street) where the majority of the new trips will be assigned through, was selected and a sensitivity analysis during the worst peak hour (PM peak hour) was conducted to determine the highest manageable capacity at that intersection under various improvements scenarios. Therefore, the results of this study provides maximum newly generated hourly traffic volumes during the PM peak hour after typical internal capture and alternative modes reductions. This study does not provide any specific threshold for the land usage density. However, various land usage scenarios may be developed which generate hourly vehicular trips of equal or less than the maximum PM peak hour trips as estimated in this study.

## 2. PROJECT DESCRIPTION

The planned River North project proposes the development of approximately 125 acres on the east side of Cumberland River between Jefferson Street and I-24 and I-65 in downtown Nashville. As shown in Figure 1, the site sits just northeast of the Nashville Central Business District (CBD).

Table 1 provides a summary of the land uses and sizes based on Phase 1 of the proposed master plan, as considered in this study, and information provided by the developer team. The current master plan for the River North development is shown in Appendix A.

TABLE 1. PHASE 1 OF THE DEVELOPMENT PROGRAM

LAND USE	SIZE
OFFICE	3,029,000 SQ. FT.
RESIDENTIAL	1,735 UNITS
HOTEL	550 ROOMS
RETAIL/RESTAURANT	258,000 SQ. FT.

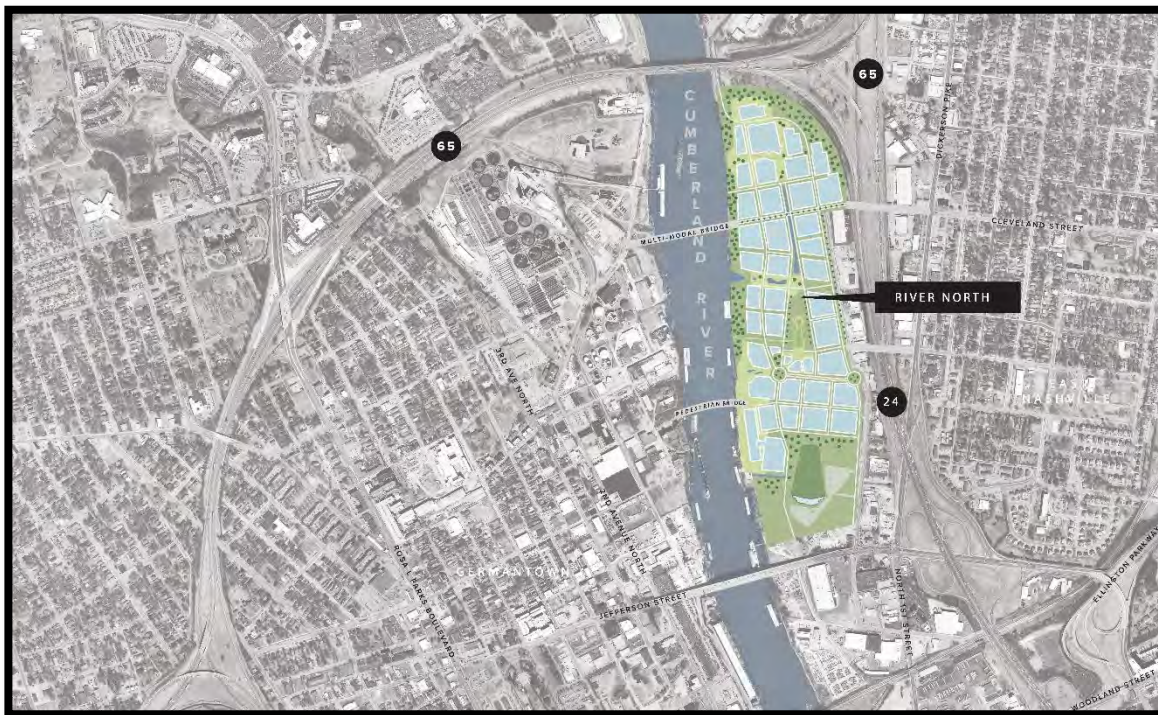

FIGURE 1. LOCATION OF THE PROJECT SITE

### 3. EXISTING SETTING

#### 3.1 Regional and Local Access

The downtown interstate network consisting of Interstates 24 and 65 will provide regional access to the site. In the vicinity of the site, these six-lane freeway facilities form part of Nashville's "Inner Loop" that encircles the downtown area of Nashville. The nearest interchanges to the site are provided at Spring Street, just east of the site, James Robertson Parkway, located approximately one mile southeast of the site and Brick Church Pike, located approximately 1.5 miles north of the site. Additional regional roadways that provide access to the site are Ellington Parkway, a four-lane expressway, Jefferson Street/Spring Street, a four to six-lane major arterial street, and Dickerson Pike/North 1<sup>st</sup> Street, another four-lane major arterial street.

Cowan Street, Vashti Street and Brick Church Pike/Baptist World Center Drive will provide local access to the site. In addition, the proposed master plan includes connections across I-24 to connect with Cleveland Street and Grace Street, which are local east-west streets that provide connections to the McFerrin Park, Cleveland Park and East Nashville areas of Nashville. In addition, new multimodal and pedestrian bridges over Cumberland River are proposed in the master plan which will enhance the connectivity of Germantown and Downtown significantly.

#### 3.2 Existing Traffic Volumes

In addition to examining the classification and laneage of the surrounding roadway network, traffic volume counts located in proximity to the site were available from a variety of sources. One of these sources is TDOT, which has permanent count stations located throughout the state that collect both daily and hourly traffic volumes. Additionally, peak period turning movement traffic counts were collected by KCI at the following locations:

1. Jefferson Street/Spring Street and Cowan Street
2. Spring Street and North 1<sup>st</sup> Street
3. Spring Street and Dickerson Pike
4. I-24 On & Off-Ramps at Spring Street
5. I-24 Eastbound Off-ramp at North 1<sup>st</sup> Street

Traffic counts for the study intersections were conducted in June 2016 by KCI. Specifically, the turning movement counts were conducted from 7:00 – 9:00 AM and 4:00 – 6:00 PM on a typical weekday in June 2016. From the counts, it was determined

that the peak hours of traffic flow for the study intersections occurred from 8:00 – 9:00 AM and 4:00 – 5:00 PM. The existing peak hour turning movement volumes are presented in Figure 2. A detailed summary of the turning movement counts is included in Appendix B.

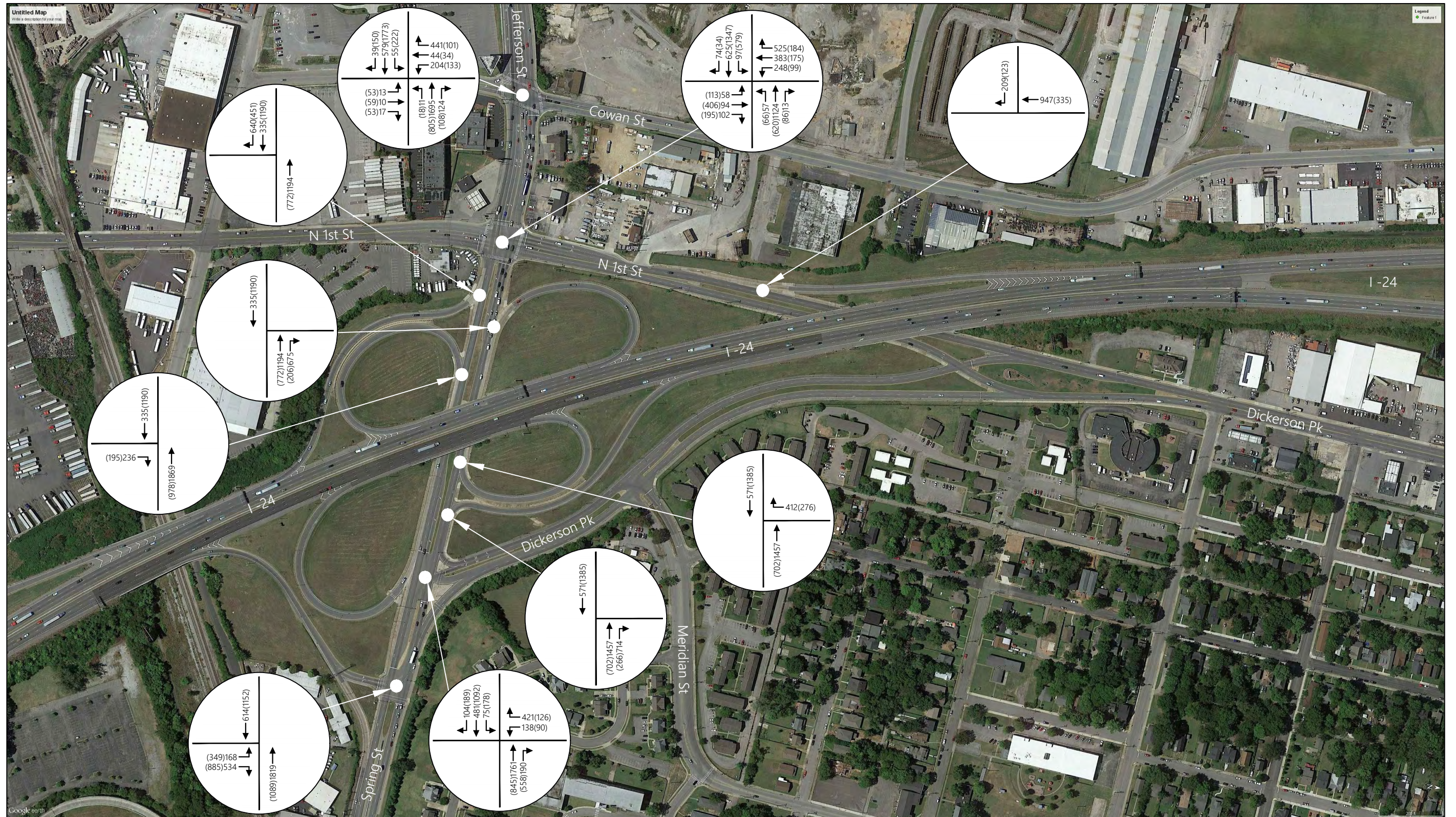

Existing Peak Hour Traffic Volumes  
(Not to Scale)

Figure 2.

In addition to the above information, average daily traffic volumes were obtained from the Tennessee Department of Transportation (TDOT). Figure 3 identifies the 2016 annual average daily traffic (AADT) at the TDOT count stations in the study area. TDOT Count Station data is included in Appendix C.

As shown in Figure 3, I-24 and I-65 carry two-way daily volumes in excess of 100,000 vehicles per day. Other streets in the project site vicinity that carry significant daily traffic volumes are Ellington Parkway (50,255 vehicles per day), Jefferson Street (31,635 vehicles per day), Dickerson Pike (18,903 vehicles per day), and James Robertson Parkway (28,363 vehicles per day). Cleveland Street, which the masterplan proposes to extend across I-24 as part of the proposed River North project, has a daily two-way traffic volume of 9,309 vehicles per day.

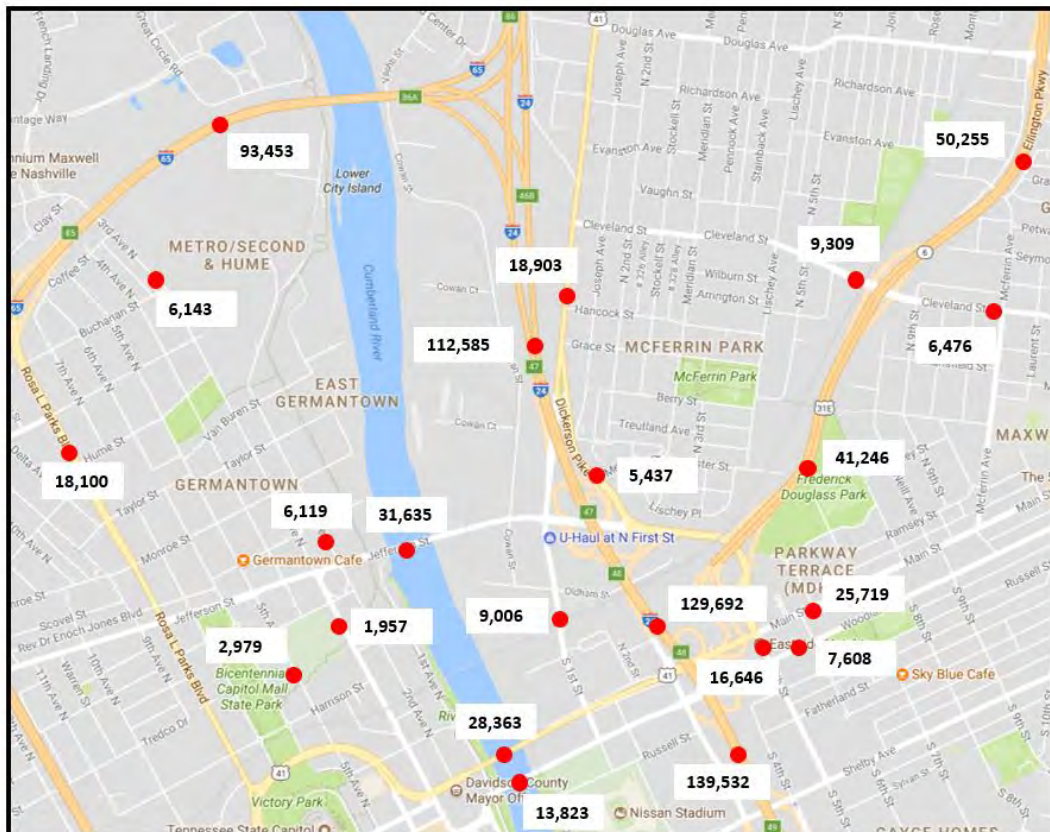

Source: TDOT

FIGURE 3. 2016 AADT DATA

### 3.3 Existing Traffic Operations

To determine the current operation of the study intersections, capacity analyses were performed for the AM and PM peak hours. The capacity calculations were performed according to the methods outlined in the *Highway Capacity Manual*, TRB 2010. The capacity analyses result in the determination of a Level of Service (LOS) for an intersection. The LOS is a concept used to describe how well an intersection or roadway operates. LOS A is the best, while LOS F is the worst. LOS D is typically considered as the minimum acceptable LOS for an intersection in an urbanized area. Table 2 present the descriptions of LOS signalized intersections, accordingly.

TABLE 2. DESCRIPTIONS OF LEVEL OF SERVICE FOR SIGNALIZED INTERSECTIONS

LEVEL OF SERVICE	DESCRIPTION	CONTROL DELAY (sec/veh)
A	Operations with very low delay. This occurs when progression is extremely favorable. Most vehicles do not stop at all.	$\leq 10$
B	Operations with stable flows. This generally occurs with good progression and/or short cycle lengths. More vehicles stop than for LOS A, causing higher levels of average delay.	$>10$ and $\leq 20$
C	Operations with stable flow. Occurs with fair progression and/or longer cycle lengths. The number of vehicles stopping is significant, although many still pass through the intersection without stopping.	$>20$ and $\leq 35$
D	Approaching unstable flow. The influence of congestion becomes more noticeable. Longer delays may result from some combination of unfavorable progression, long cycle lengths, or high V/C ratios. Many vehicles stop.	$>35$ and $\leq 55$
E	Unstable flow. This is considered to be the limit for acceptable delay. These high delays generally indicate poor progression, long cycle lengths, and high V/C ratios.	$>55$ and $\leq 80$
F	Unacceptable delay. This condition often occurs with over saturation or with high V/C ratios. Poor progression and long cycle lengths may also cause such delay levels.	$>80.0$

Source: *Highway Capacity Manual*, TRB 2010

The results of the capacity analyses for the existing conditions at the intersections studied are presented in Table 3 and Table 4 for the AM and PM peak hours, accordingly. Each of these intersections is signalized. As shown, the signalized intersection of Jefferson Street and Cowan Street operates at LOS D and LOS C during the AM and PM peak hours, respectively. The intersection of Spring Street and North



1<sup>st</sup> Street operates at LOS E during the AM peak hour and LOS D during the PM peak hour. The intersection of Spring Street and Dickerson Pike operates at LOS D during the AM peak hour and LOS B during the PM peak hour. The intersection of Spring Street and I-24 WB Off-Ramp operates at LOS B during the AM peak hour and LOS A during the PM peak hour. Capacity analyses worksheets are included in Appendix D.

TABLE 3. EXISTING AM PEAK HOUR LEVELS OF SERVICE

INTERSECTION	TURNING MOVEMENT	LEVEL OF SERVICE (Average Approach Delay in sec/veh) AM Peak Hour
Jefferson Street & Cowan Street	Overall Intersection	D (53.9)
Spring Street & North 1 <sup>st</sup> Street	Overall Intersection	E (69.9)
Spring Street & Dickerson Pike*	Overall Intersection	D (35.6)
Spring Street & I-24 WB Off-Ramp*	Overall Intersection	B (13.3)
<i>Note: Asterisks denote intersections that utilize non-NEMA phasing and are, therefore, analyzed using HCM 2000 results</i>		

TABLE 4. EXISTING PM PEAK HOUR LEVELS OF SERVICE

INTERSECTION	TURNING MOVEMENT	LEVEL OF SERVICE (Average Approach Delay in sec/veh) PM Peak Hour
Jefferson Street & Cowan Street	Overall Intersection	C (20.1)
Spring Street & North 1 <sup>st</sup> Street	Overall Intersection	D (48.4)
Spring Street & Dickerson Pike*	Overall Intersection	B (13.5)
Spring Street & I-24 WB Off-Ramp*	Overall Intersection	A (8.8)
<i>Note: Asterisks denote intersections that utilize non-NEMA phasing and are, therefore, analyzed using HCM 2000 results</i>		

## 4. IMPACTS

### 4.1 Trip Generation

A traffic generation process was used to estimate the amount of traffic expected to be generated by Phase 1 of the proposed River North development. Factors for the trip generation were taken from ITE's *Trip Generation*, Ninth Edition. As previously discussed, Phase 1 of the proposed development, as considered in this analysis, consists of a total of approximately three (3) million square feet of office space, 1,735 residential units, 285,000 square feet of retail/restaurant space, 550 hotel rooms and 186,500 square feet of civic space. As part of the development of the project site, significant pedestrian infrastructure improvements are planned to be included both within the project site and along the adjacent public rights-of-way. Additionally, the project site is located in an area that already includes a relatively dense mix of land uses with regular transit service. Therefore, using reductions in the base ITE trip generation rates, 5% reductions were applied to account for walking, biking, and transit modes, conservatively.

Data presented in the ITE publication, *Trip Generation Handbook*, shows that developments containing multiple land uses will commonly have internal trips. A process was used to estimate the amount of internal trips that can be expected between land uses based on methodology presented in NCHRP Report 684, "Enhancing Internal Trip Capture Estimation for Mixed-Use Developments." The methodology contained in the NCHRP Report expands on ITE's methodology, including additional land uses and supporting data. The internal trip reduction process resulted in an approximate 22% internal capture rate for the AM, 19% for the PM, and 20% for daily trip generation under full buildout scenario of the proposed development.

Table 6 presents the daily, AM, and PM peak hour trip generation for Phase 1 of the proposed mixed-use development. As shown by Table 6, Phase 1 of the proposed development, as considered in this analysis, is expected to generate approximately 36,949 new trips per day. The AM and PM peak hour trip generations will equal approximately 3,634, and 4,483 new trips, respectively. As it was mentioned previously, the traffic analysis is based on more density than is currently contemplated by the developer. Given variables such as local demand and overall economy, it is prudent to underwrite conservatively. The calculations for trip generation are included in Appendix E.

TABLE 5. DEVELOPMENT TRIP GENERATION (PHASE 1)

LAND USE	SIZE	GENERATED TRAFFIC <sup>1</sup>				
		DAILY TRIPS	AM PEAK HOUR		PM PEAK HOUR	
			ENTER	EXIT	ENTER	EXIT
Office (LUC 710)	3,029,000 s.f.	13,328	2,163	233	535	2,623
Retail (LUC 826)	200,000 s.f.	6,531	52	74	80	102
Restaurant <sup>2</sup>	58,000 s.f.	5,549	142	149	187	66
Apartments (LUC 220)	1,735 d.u.	8,084	151	486	402	233
Hotel (LUC 310)	550 rooms	3,457	157	27	122	133
SUBTOTAL		36,949	2,665	969	1,326	3,157
<b>NEW TRIPS</b>		<b>36,949</b>	<b>3,634</b>		<b>4,483</b>	

Notes:  
1) Calculations above represent only new traffic generated by the project site. The internal trips and alternative mode trips are not included in the numbers above.  
2) Combination of LUC 931, LUC 932, and LUC 936

Source: *Trip Generation*, Ninth Edition

## 4.2 Evaluation

As mentioned previously, the master plan proposed a variety of new roadway extensions, bridges, interchanges and access connections to the Interstate system as well as to existing streets. Various combinations of the potential improvements within the study area were developed. Directional distributions of traffic generated by the proposed project were then established based on the proposed access connections under each scenario and the existing travel patterns developed from the existing peak hour traffic counts. Capacity analysis using Synchro 9 along with a sensitivity analysis were then conducted at the critical study intersections to estimate the maximum new trip-generated traffic volumes by the proposed development which can be managed under each scenario.

It should be noted that since the existing operational performance at the study intersections indicated that at least one of the intersections (Spring Street and North 1<sup>st</sup> Street) operates at LOS E during the peak hours, some improvements are required to be implemented upon the construction of the proposed development at any stage if LOS D operation is to be achieved.

For the purpose of this study and based on the capacity analysis it was determined that the intersection of Jefferson Street/Spring Street and Cowan Street is the control intersection for the sensitivity analysis. In addition, the proposed development has higher impacts at that intersection during the PM peak hour when compared to the AM peak hour. As a result, for the sensitivity analysis, capacity analyses were conducted at the intersection of Jefferson Street/Spring Street and Cowan Street during the PM peak hour under each of the various scenarios.

Directional distribution within the study area and specifically the study intersection of Jefferson Street/Spring Street and Cowan Street varies based on the proposed improvements. Consequently, directional distributions under each scenario were developed and the maximum newly generated trips by the proposed development, which can be managed under each scenario was determined. Description of the proposed improvements, specific directional distributions, and the maximum new trip-generated traffic volumes by the proposed development (based on the PM peak hour volumes) which can be accommodated under each scenario are presented as follows.

### 4.2.1 Low Level and Medium Level Improvements

Under the low level and medium level improvements scenarios, the proposed developments do not include construction of any new roadway bridges and/or connectors. Moreover, under the low-level improvements scenario, widening of

Jefferson Street/Spring Street within the study area is not being considered. However, under the scenario with medium level improvements, potential improvements which require widening of Jefferson Street/Spring Street within the study area were considered and included in the analysis. Since no new roadway connectors were proposed under either the low level and medium level improvements scenarios, the same directional distribution was utilized for both scenarios. Figure 4, Table 7, and Table 8 present the directional distribution, proposed improvements, and maximum newly generated trips by the proposed development that can be accommodated by implementing those improvements. Conceptual recommended improvements at the intersection of Jefferson Street/Spring Street and Cowan Street under low-level and medium-level improvements scenarios are presented in Figure 5 and Figure 6.

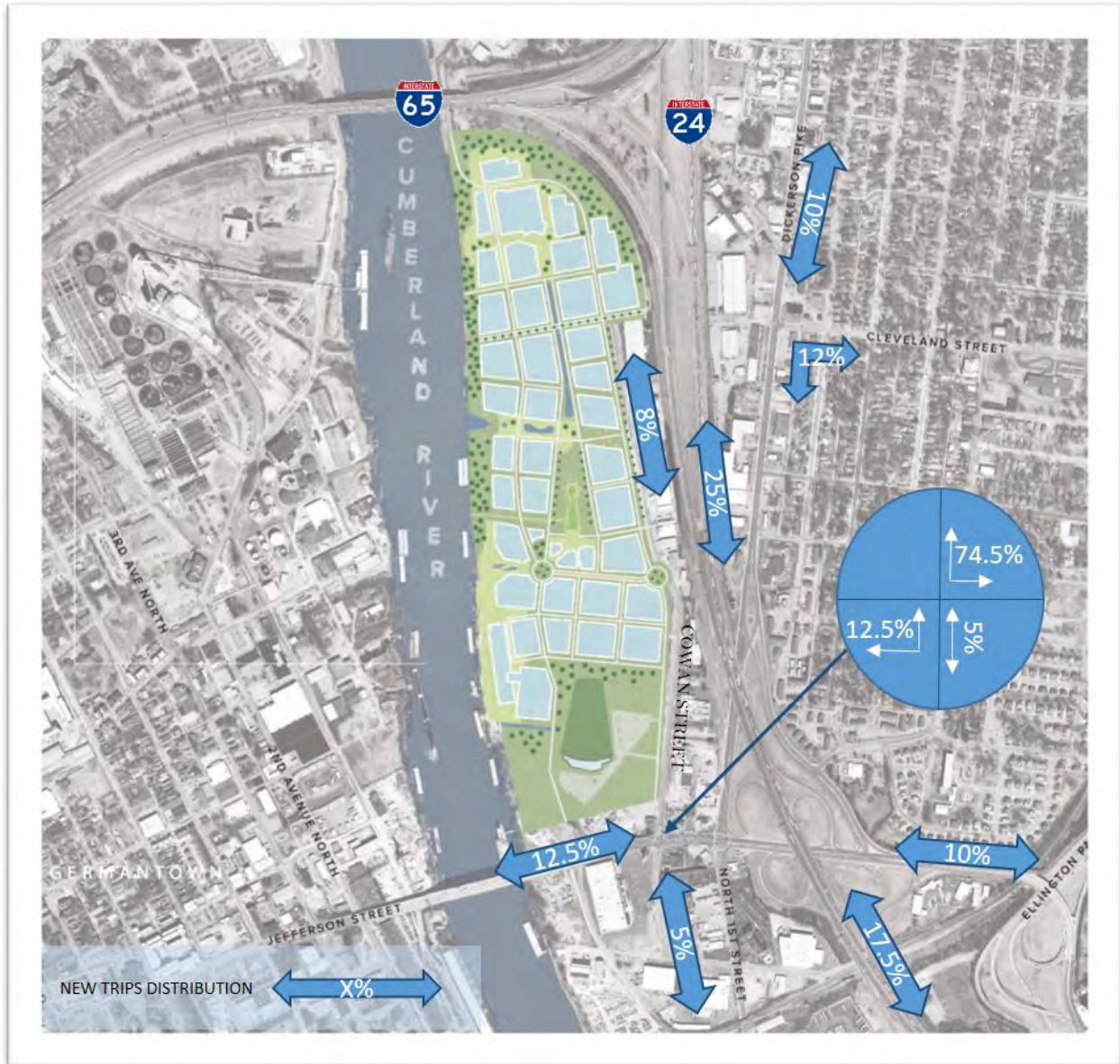

FIGURE 4. DIRECTIONAL DISTRIBUTION OF TRAFFIC GENERATED BY THE PROJECT SITE UNDER LOW-LEVEL AND MEDIUM-LEVEL IMPROVEMENTS

TABLE 6. MAXIMUM NEWLY GENERATED TRIPS BY THE PROPOSED DEVELOPMENT DURING PM PEAK HOUR UNDER LOW-LEVEL IMPROVEMENTS SCENARIO

LOW-LEVEL IMPROVEMENTS <ul style="list-style-type: none"> <li>No additional eastbound lane on Jefferson Street/Spring Street at Cowan Street is required.</li> <li>Widen Cowan Street southbound to include two left-turn lanes, one through lane, and one right-turn lane.</li> <li>Provide a westbound right-turn lane with free-flow operation on Spring Street at Cowan Street.</li> </ul>		
MAXIMUM NEWLY GENERATED TRIPS BY THE PROPOSED DEVELOPMENT DURING PM PEAK HOUR		
TOTAL	ENTER	EXIT
983 (22% of Newly Generated Trips by Total Buildout of Phase 1 of the Development During the PM Peak Hour)	360	623

TABLE 7. MAXIMUM NEWLY GENERATED TRIPS BY THE PROPOSED DEVELOPMENT DURING PM PEAK HOUR UNDER MEDIUM-LEVEL IMPROVEMENTS SCENARIO

MEDIUM-LEVEL IMPROVEMENTS <ol style="list-style-type: none"> <li>Widen Jefferson Street to include an additional eastbound through lane at Cowan Street.<sup>1</sup></li> <li>Widen Cowan Street southbound to include three left-turn lanes, one shared through/right-turn lane, and one right-turn lane.</li> <li>Provide a westbound right-turn lane with free-flow operation on Spring Street at Cowan Street.</li> </ol> Notes: 1) Feasible alternatives should be considered to determine the need for the widening of the eastern section of the Jefferson Street bridge in order to accommodate this additional eastbound through lane 2) Widening of the I-24 bridge and ramps improvements within the study area are likely to be required.		
MAXIMUM NEWLY GENERATED TRIPS BY THE PROPOSED DEVELOPMENT DURING PM PEAK HOUR		
TOTAL	ENTER	EXIT
2,700 (60% of Newly Generated Trips by Total Buildout of Phase 1 of the Development During the PM Peak Hour)	1,146	1,554

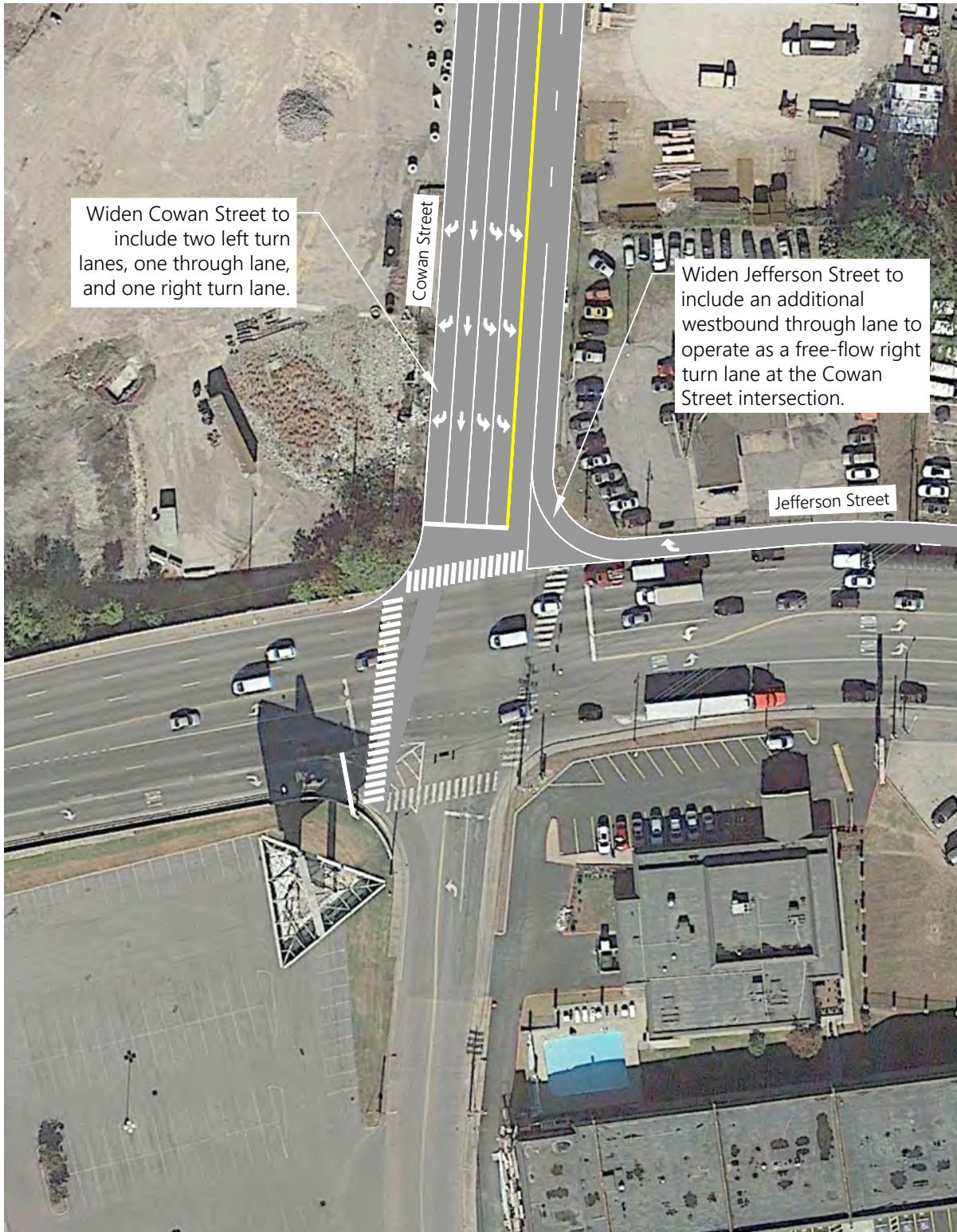

Widen Cowan Street to include two left turn lanes, one through lane, and one right turn lane.

Widen Jefferson Street to include an additional westbound through lane to operate as a free-flow right turn lane at the Cowan Street intersection.



Recommended Improvements - Low Level Improvements



Figure 5.



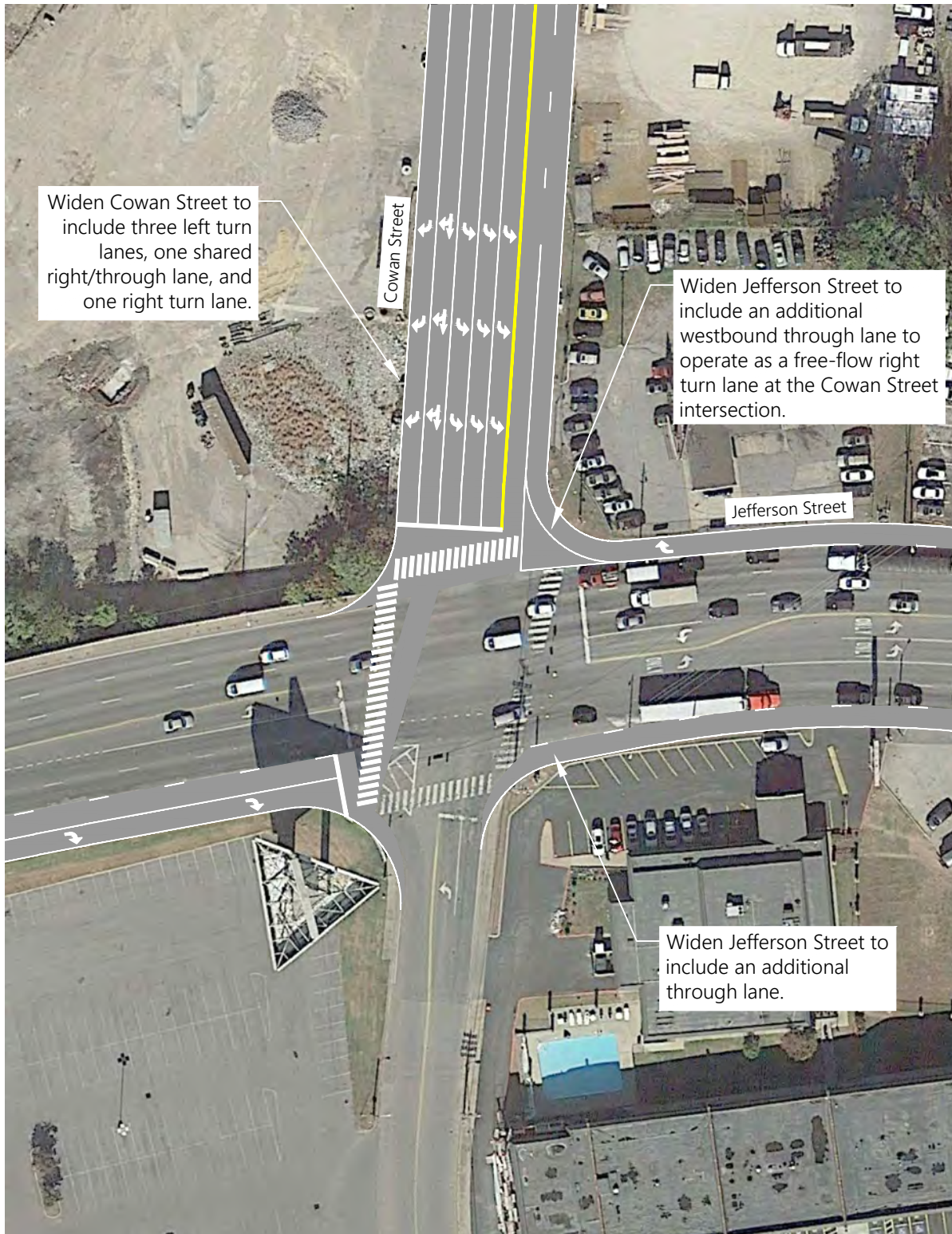

Recommended Improvements - Medium Level Improvements



Figure 6.

### 4.2.2 High-Level Improvements

Under the high-level improvements scenarios, construction of new roadway connectors and bridges were considered as part of the potential developments in addition to the proposed improvements under the medium-level improvements scenario. Several high-level improvement scenarios were evaluated using revised directional distributions that would result with the specific improvements. Directional distributions, proposed improvements, and maximum newly generated trips which can be accommodated by implementing those improvements are presented in the following tables and figures.

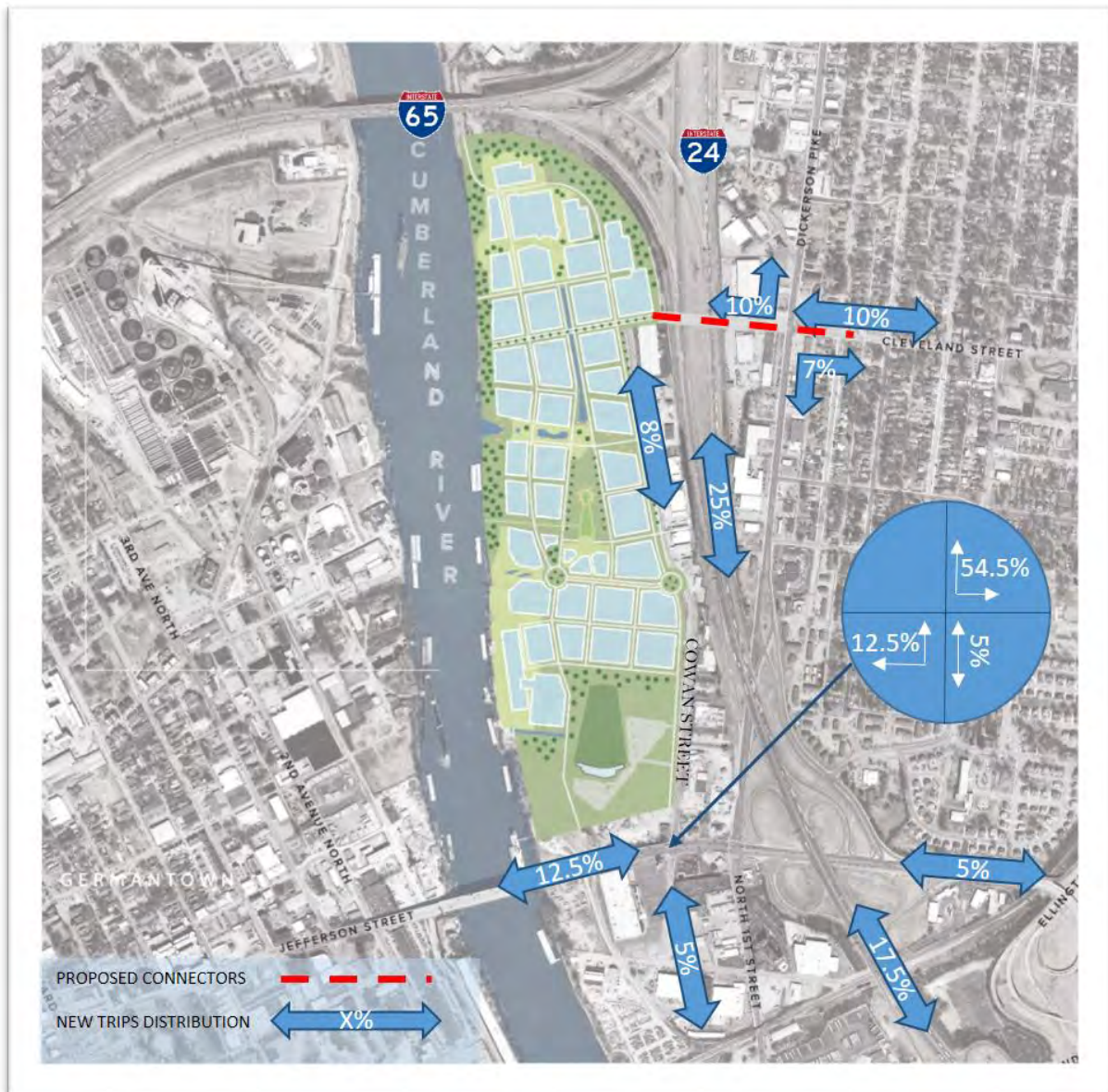

FIGURE 7. DIRECTIONAL DISTRIBUTION OF TRAFFIC GENERATED BY THE PROJECT SITE HIGH-LEVEL IMPROVEMENTS-OPTION 1

TABLE 8. MAXIMUM NEWLY GENERATED TRIPS BY THE PROPOSED DEVELOPMENT DURING PM PEAK HOUR UNDER HIGH-LEVEL IMPROVEMENTS SCENARIO-OPTION 1

HIGH-LEVEL IMPROVEMENTS-OPTION 1			
<ul style="list-style-type: none"> <li>Provide a new roadway connector across I-24 between Cleveland Street and the proposed development.</li> </ul>			
ADDITIONAL IMPROVEMENTS-OPTION 1A			
Include medium-level improvements #1, and #3 as described in Table 7 in addition to the following:			
<ul style="list-style-type: none"> <li>Widen Cowan Street southbound to include two left-turn lanes, one shared through/right-turn lane, and one right-turn lane.</li> </ul>			
Note: Widening of the I-24 bridge and ramps improvements within the study area are likely to be required.			
ADDITIONAL IMPROVEMENTS-OPTION 1B			
Include all the medium-level improvements as described in Table 7.			
Note: Widening of the I-24 bridge and ramps improvements within the study area are likely to be required.			
ADDITIONAL IMPROVEMENTS-OPTION 1C			
Include all the low-level improvements as described in Table 6.			
<b>MAXIMUM NEWLY GENERATED TRIPS BY THE PROPOSED DEVELOPMENT DURING PM PEAK HOUR</b>			
OPTIONS	TOTAL	ENTER	EXIT
OPTION 1A	1,350 (30% of Newly Generated Trips by Total Buildout of Phase 1 of the Development During the PM Peak Hour)	573	777
OPTION 1B	3,240 (72% of Newly Generated Trips by Total Buildout of Phase 1 of the Development During the PM Peak Hour)	1,375	1,865
OPTION 1C	1,215 (27% of Newly Generated Trips by Total Buildout of Phase 1 of the Development During the PM Peak Hour)	516	699

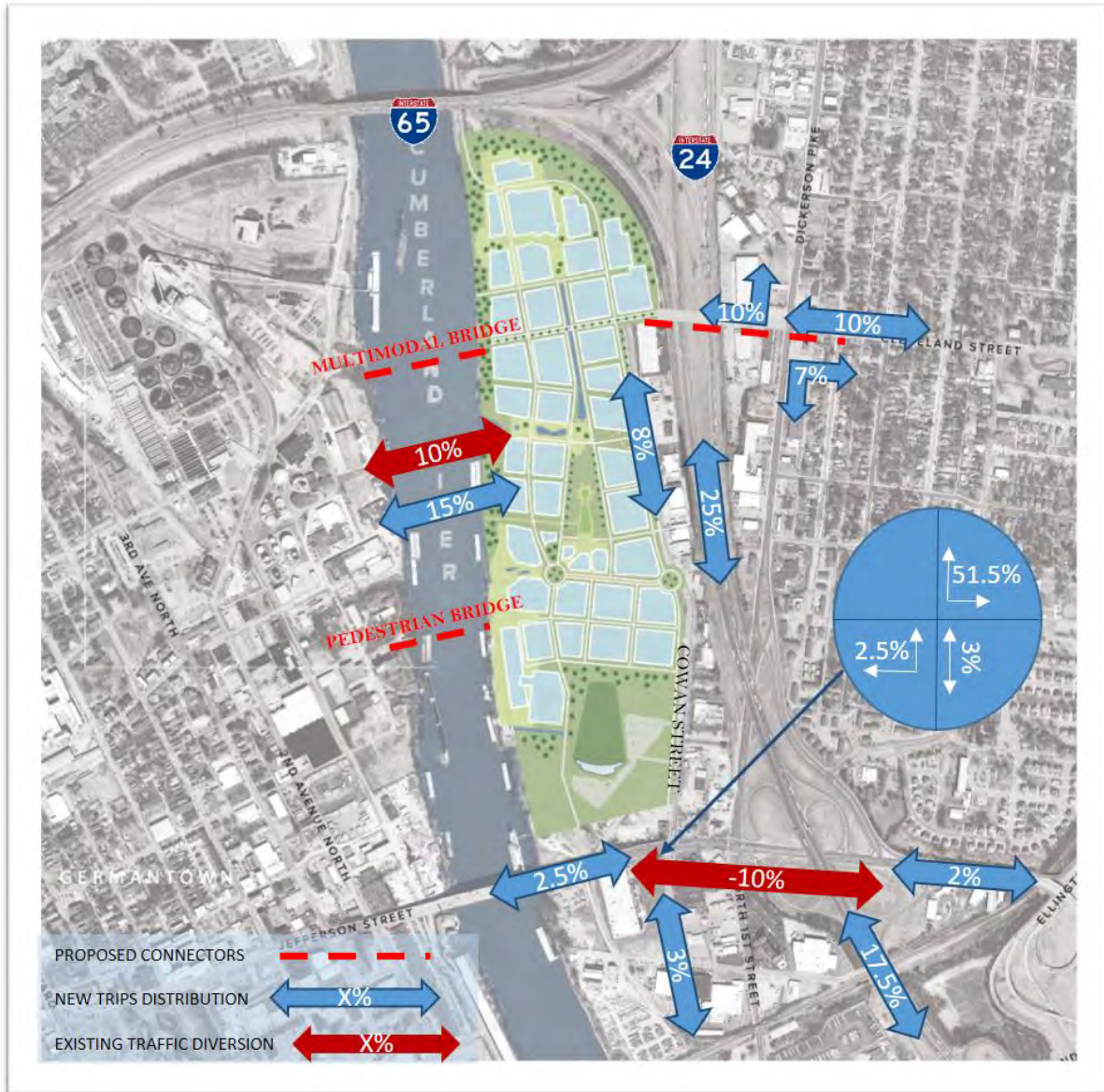

FIGURE 8. DIRECTIONAL DISTRIBUTION OF TRAFFIC GENERATED BY THE PROJECT SITE HIGH-LEVEL IMPROVEMENTS-OPTION 2

TABLE 9. MAXIMUM NEWLY GENERATED TRIPS BY THE PROPOSED DEVELOPMENT DURING PM PEAK HOUR UNDER HIGH-LEVEL IMPROVEMENTS SCENARIO-OPTION 2

HIGH-LEVEL IMPROVEMENTS-OPTION 2			
<ul style="list-style-type: none"> <li>• Provide a new roadway connector across I-24 between Cleveland Street and the proposed development.</li> <li>• Provide new pedestrian and multimodal bridge connectors to Germantown over Cumberland River.</li> </ul>			
<p>ADDITIONAL IMPROVEMENTS-<b>OPTION 2A</b></p> <p>Include medium-level improvements #1, and #3 as described in Table 7 in addition to the following:</p> <ul style="list-style-type: none"> <li>• Widen Cowan Street southbound to include two left-turn lanes, one shared through/right-turn lane, and one right-turn lane.</li> </ul> <p>Note: Widening of the I-24 bridge and ramps improvements within the study area are likely to be required.</p>			
<p>ADDITIONAL IMPROVEMENTS-<b>OPTION 2B</b></p> <p>Include all the medium-level improvements as described in Table 7.</p> <p>Note: Widening of the I-24 bridge and ramps improvements within the study area are likely to be required.</p>			
<p>ADDITIONAL IMPROVEMENTS-<b>OPTION 2C</b></p> <p>Include all the low-level improvements as described in Table 6.</p>			
MAXIMUM NEWLY GENERATED TRIPS BY THE PROPOSED DEVELOPMENT DURING PM PEAK HOUR			
OPTIONS	TOTAL	ENTER	EXIT
OPTION 2A	2,970 (66% of Newly Generated Trips by Total Buildout of Phase 1 of the Development During the PM Peak Hour)	1,261	1,709
OPTION 2B	4,590 (102% of Newly Generated Trips by Total Buildout of Phase 1 of the Development During the PM Peak Hour)	1,948	2,642
OPTION 2C	1,620 (36% of Newly Generated Trips by Total Buildout of Phase 1 of the Development During the PM Peak Hour)	688	932

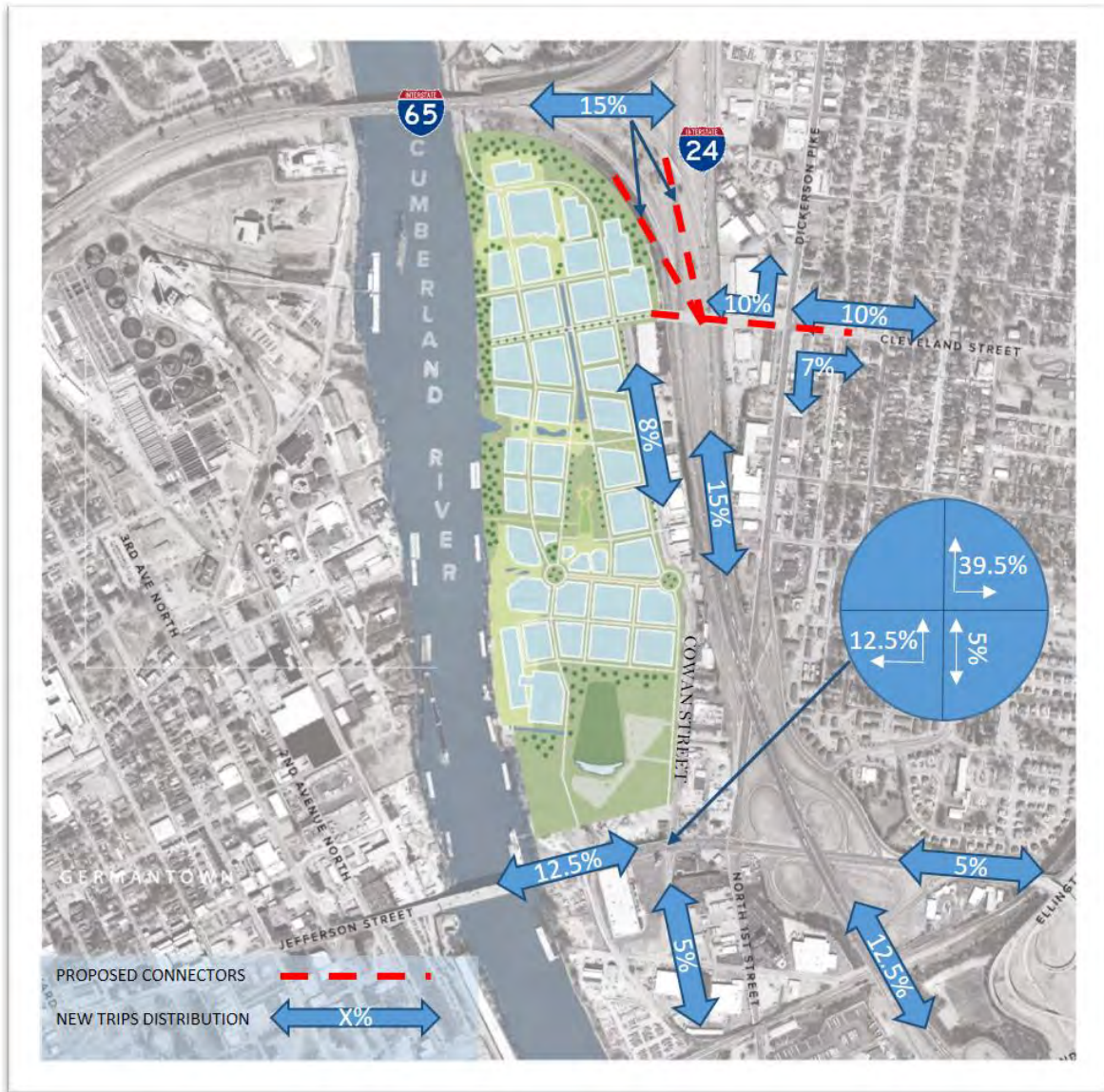

FIGURE 9. DIRECTIONAL DISTRIBUTION OF TRAFFIC GENERATED BY THE PROJECT SITE HIGH-LEVEL IMPROVEMENTS-OPTION 3

TABLE 10. MAXIMUM NEWLY GENERATED TRIPS BY THE PROPOSED DEVELOPMENT DURING PM PEAK HOUR UNDER HIGH-LEVEL IMPROVEMENTS SCENARIO-OPTION 3

HIGH-LEVEL IMPROVEMENTS-OPTION 3			
<ul style="list-style-type: none"> <li>Provide a new roadway connector across I-24 between Cleveland Street and the proposed development with partial movements' accesses to Interstate.</li> </ul>			
<p>ADDITIONAL IMPROVEMENTS-<b>OPTION 3A</b></p> <p>Include medium-level improvements #1, and #3 as described in Table 7 in addition to the following:</p> <ul style="list-style-type: none"> <li>Widen Cowan Street southbound to include two left-turn lanes, one shared through/right-turn lane, and one right-turn lane.</li> </ul> <p>Note: Widening of the I-24 bridge and ramps improvements within the study area are likely to be required.</p>			
<p>ADDITIONAL IMPROVEMENTS-<b>OPTION 3B</b></p> <p>Include all the medium-level improvements as described in Table 7.</p> <p>Note: Widening of the I-24 bridge and ramps improvements within the study area are likely to be required.</p>			
<p>ADDITIONAL IMPROVEMENTS-<b>OPTION 3C</b></p> <p>Include all the low-level improvements as described in Table 6.</p>			
MAXIMUM NEWLY GENERATED TRAFFIC VOLUMES BY THE PROPOSED DEVELOPMENT DURING PM PEAK HOUR			
OPTIONS	TOTAL	ENTER	EXIT
OPTION 3A	2,970 (66% of Newly Generated Trips by Total Buildout of Phase 1 of the Development During the PM Peak Hour)	1,261	1,709
OPTION 3B	4,050 (90% of Newly Generated Trips by Total Buildout of Phase 1 of the Development During the PM Peak Hour)	1,719	2,331
OPTION 3C	1,620 (36% of Newly Generated Trips by Total Buildout of Phase 1 of the Development During the PM Peak Hour)	688	932

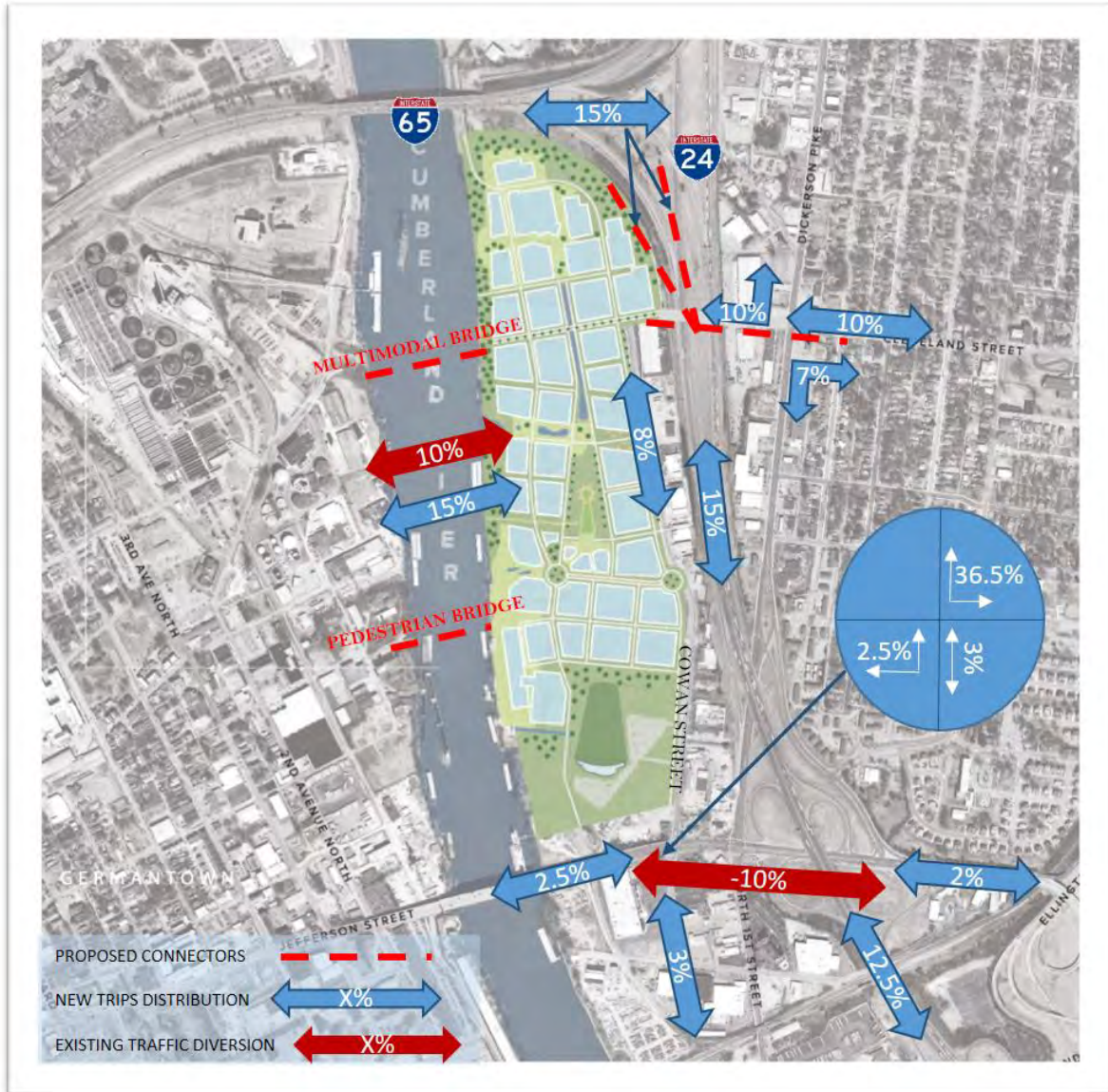

FIGURE 10. DIRECTIONAL DISTRIBUTION OF TRAFFIC GENERATED BY THE PROJECT SITE  
HIGH-LEVEL IMPROVEMENTS-OPTION 4



TABLE 11. MAXIMUM NEWLY GENERATED TRIPS BY THE PROPOSED DEVELOPMENT DURING PM PEAK HOUR UNDER HIGH-LEVEL IMPROVEMENTS SCENARIO-OPTION 4

HIGH-LEVEL IMPROVEMENTS-OPTION 4			
<ul style="list-style-type: none"> <li>• Provide a new roadway connector across I-24 between Cleveland Street and the proposed development with partial movements' accesses to Interstate.</li> <li>• Provide new pedestrian and multimodal bridge connectors to Germantown over Cumberland River.</li> </ul>			
<p>ADDITIONAL IMPROVEMENTS-<b>OPTION 4A</b></p> <p>Include medium-level improvements #1, and #3 as described in Table 7 in addition to the following:</p> <ul style="list-style-type: none"> <li>• Widen Cowan Street southbound to include two left-turn lanes, one shared through/right-turn lane, and one right-turn lane.</li> </ul> <p>Note: Widening of the I-24 bridge and ramps improvements within the study area are likely to be required.</p>			
<p>ADDITIONAL IMPROVEMENTS-<b>OPTION 4B</b></p> <p>Include all the medium-level improvements as described in Table 7.</p> <p>Note: Widening of the I-24 bridge and ramps improvements within the study area are likely to be required.</p>			
<p>ADDITIONAL IMPROVEMENTS-<b>OPTION 4C</b></p> <p>Include all the low-level improvements as described in Table 6.</p>			
MAXIMUM NEWLY GENERATED TRIPS BY THE PROPOSED DEVELOPMENT DURING PM PEAK HOUR			
OPTION	TOTAL	ENTER	EXIT
OPTION 4A	4,050 (90% of Newly Generated Trips by Total Buildout of Phase 1 of the Development During the PM Peak Hour)	1,719	2,331
OPTION 4B	5,940 (133% of Newly Generated Trips by Total Buildout of Phase 1 of the Development During the PM Peak Hour)	2,521	3,419
OPTION 4C	2,430 (54% of Newly Generated Trips by Total Buildout of Phase 1 of the Development During the PM Peak Hour)	1,031	1,399

### 4.2.3 Cowan Street Cross-Section

Total projected traffic volumes and lane configurations at the control study intersection of Jefferson Street/Spring Street and Cowan Street are presented in Figure 9 through Figure 13. As shown in the figures, total bi-directional projected traffic volumes on Cowan Street north of Jefferson Street/Spring Street during the PM Peak

hour (worst case) is expected to be within the range of 1,365-4,934 vehicles per hour under various improvements scenarios.

An urban roadway with 4,934 traffic volumes during the peak hour is very likely to carry daily trips of more than 40,000 vehicles per day, which typically requires a six-lane cross-section. The aesthetics and functionality of this wide of a roadway, however, is not compatible with the livability desires for the development or the overall vision for the downtown core – one that is walkable and supports a thriving transit system. The blank slate the site provides allows Metro to “rightsize” this corridor from the concept phase to ensure a functional and livable urban neighborhood environment that flourishes in the near-term, while allowing for strategic right-of-way dedication to adequately accommodate future growth. Whether the roadway needs to be widened to enhance mobility along the corridor, such as through the addition of turn lanes at intersections, dedicated transit lanes, or improvements for non-motorized users, having an appropriate amount of right-of-way already set aside will ensure that future buildings are appropriately located along the street’s frontage and also provide a tremendous amount of cost savings and effort for Metro in the future. Long-term planning considerations such as these also better positions this critical area, which will act as a gateway into and out of downtown, to play an effective role in accomplishing the city’s grander visions for multimodal transportation as growth continues.

Other mobility strategies within the study area could be considered and coordinated between the development team and Metro Nashville in order to achieve the high densities envisioned for the proposed development. Those strategies are likely to improve the mobility of the study area and to avoid extensive widening of Cowan Street. Some of the potential recommendations are described in the conclusions section of this study.

LANE CONFIGURATIONS

TOTAL PROJECTED TRAFFIC VOLUMES

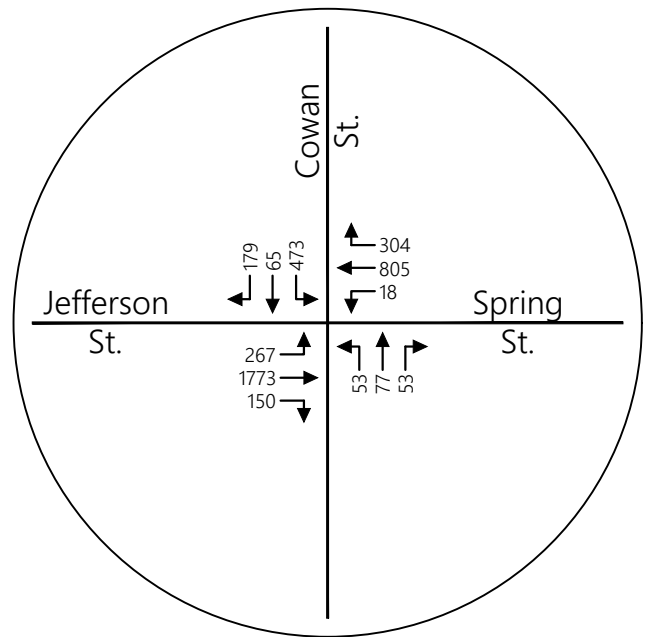
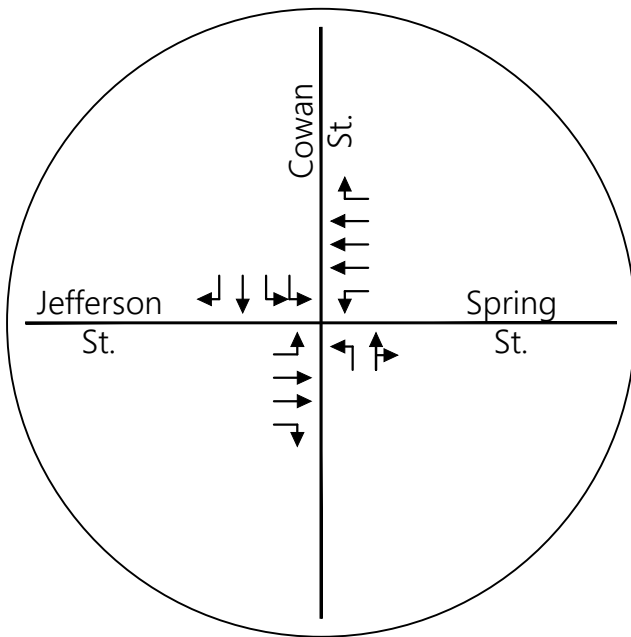

XXX - PM Peak Hour  
Traffic Volumes



Total Projected Peak Hour Traffic Volumes (Low-Level Improvements)  
(Not to Scale)

Figure 11.

LANE CONFIGURATIONS

TOTAL PROJECTED TRAFFIC VOLUMES

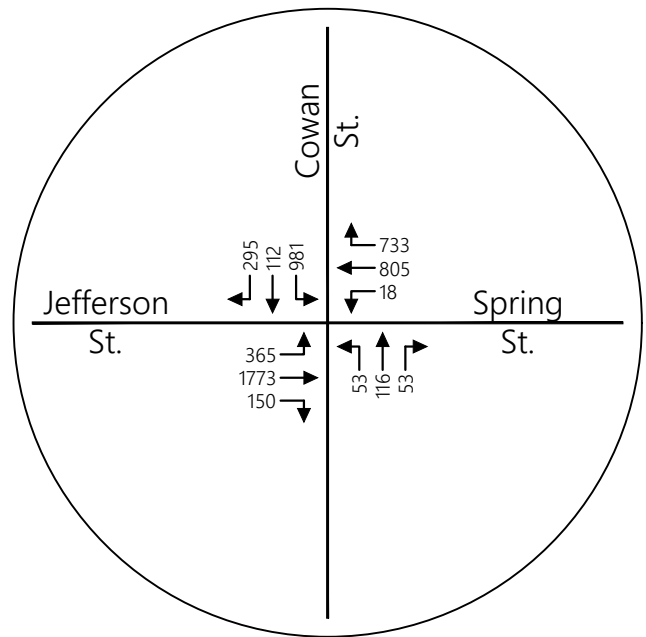
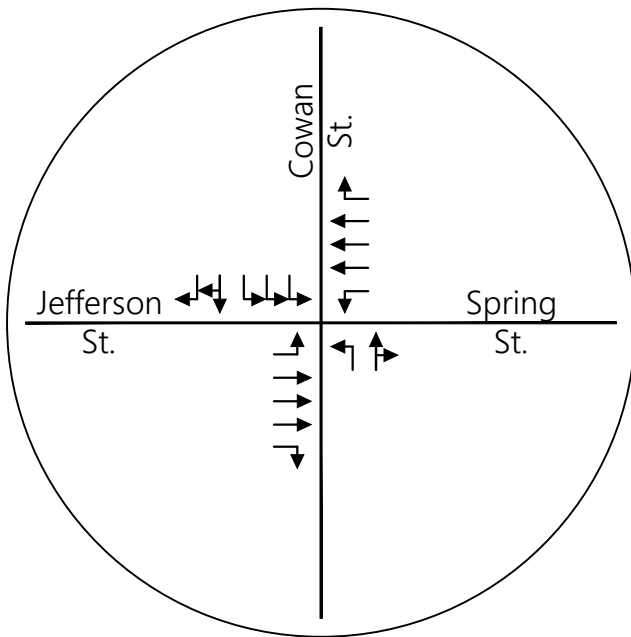

XXX - PM Peak Hour  
Traffic Volumes



Total Projected Peak Hour Traffic Volumes (Medium-Level Improvements)  
(Not to Scale)

Figure 12.

LANE CONFIGURATIONS

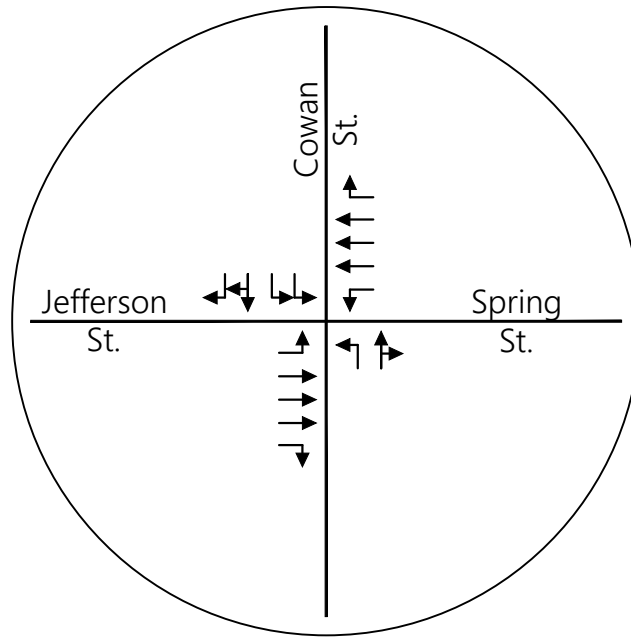

TOTAL PROJECTED TRAFFIC VOLUMES  
OPTION 1A

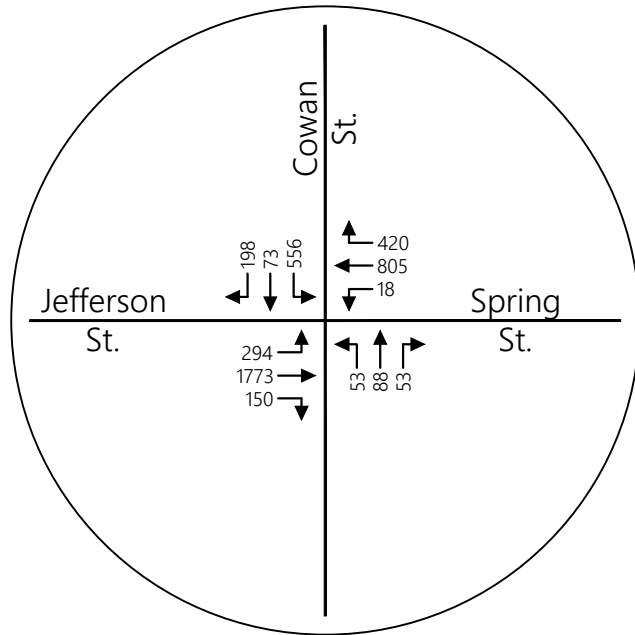

TOTAL PROJECTED TRAFFIC VOLUMES  
OPTION 2A

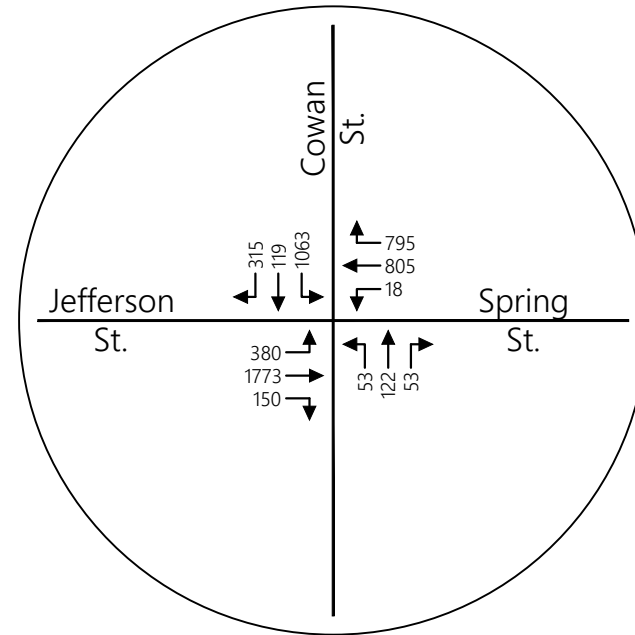

TOTAL PROJECTED TRAFFIC VOLUMES  
OPTION 3A

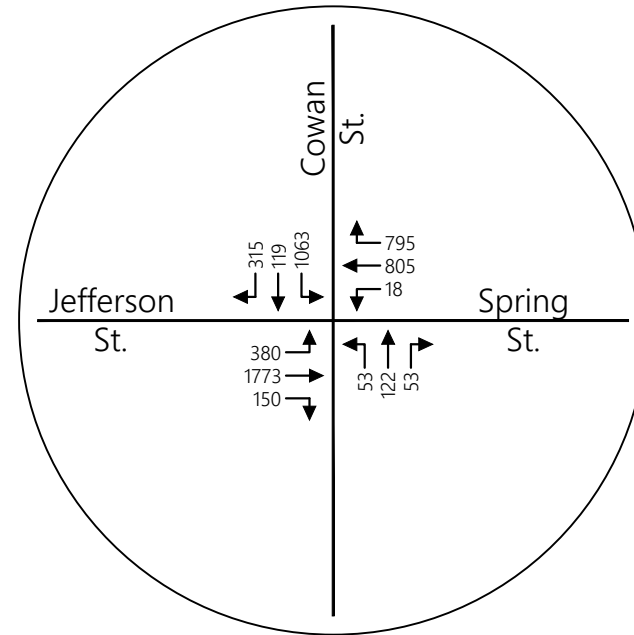

TOTAL PROJECTED TRAFFIC VOLUMES  
OPTION 4A

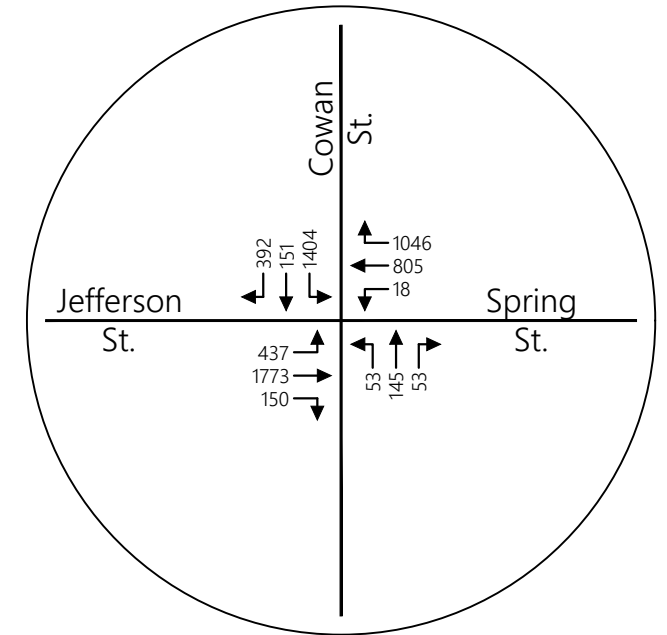

XXX - PM Peak Hour  
Traffic Volumes



Total Projected Peak Hour Traffic Volumes (High-Level Improvements - A)  
(Not to Scale)

Figure 13.

LANE CONFIGURATIONS

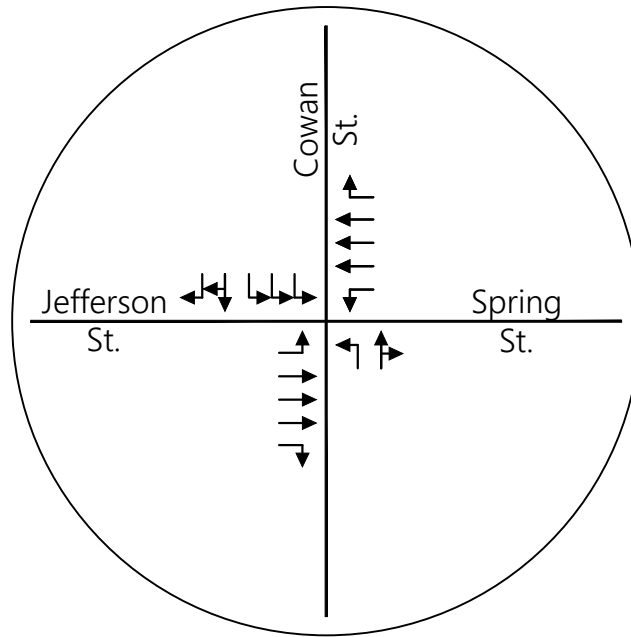

TOTAL PROJECTED TRAFFIC VOLUMES  
OPTION 1B

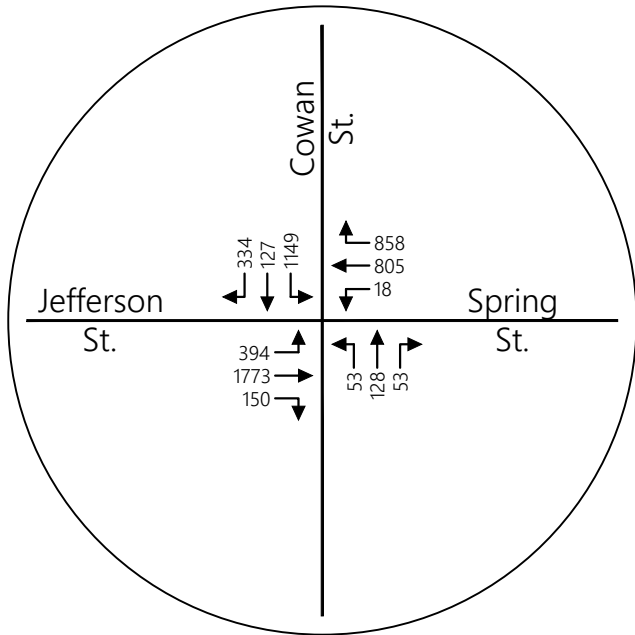

TOTAL PROJECTED TRAFFIC VOLUMES  
OPTION 2B

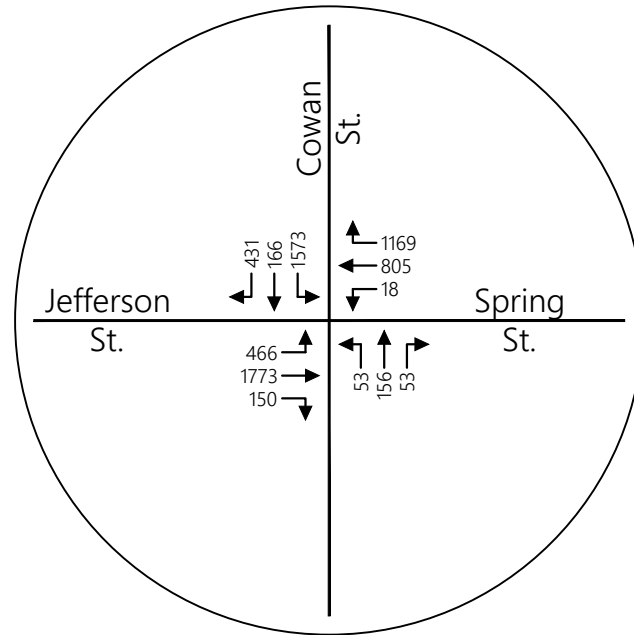

TOTAL PROJECTED TRAFFIC VOLUMES  
OPTION 3B

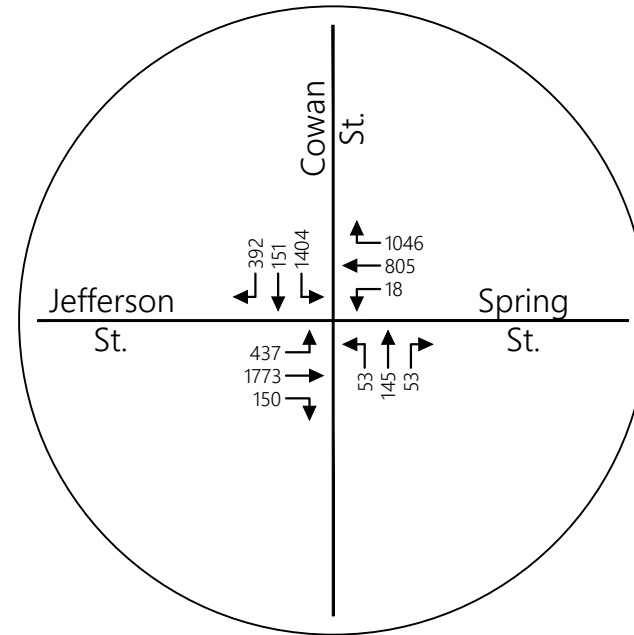

TOTAL PROJECTED TRAFFIC VOLUMES  
OPTION 4B

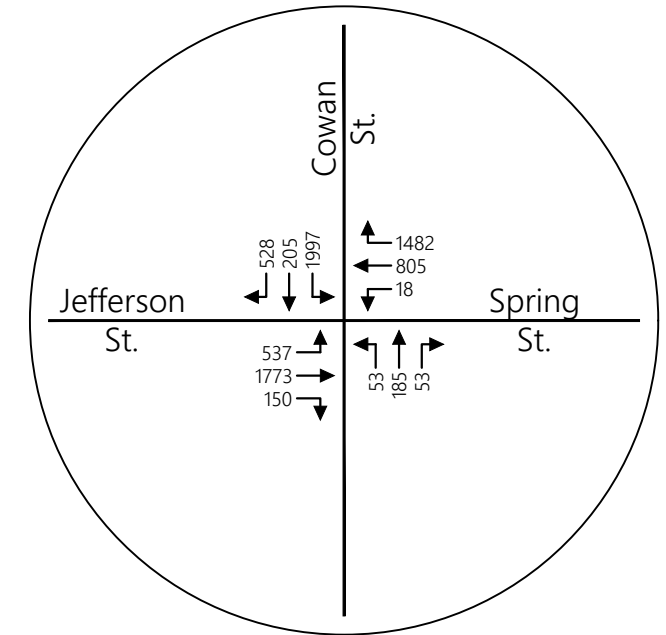

XXX - PM Peak Hour  
Traffic Volumes



Total Projected Peak Hour Traffic Volumes (High-Level Improvements - B)  
(Not to Scale)

Figure 14.

LANE CONFIGURATIONS

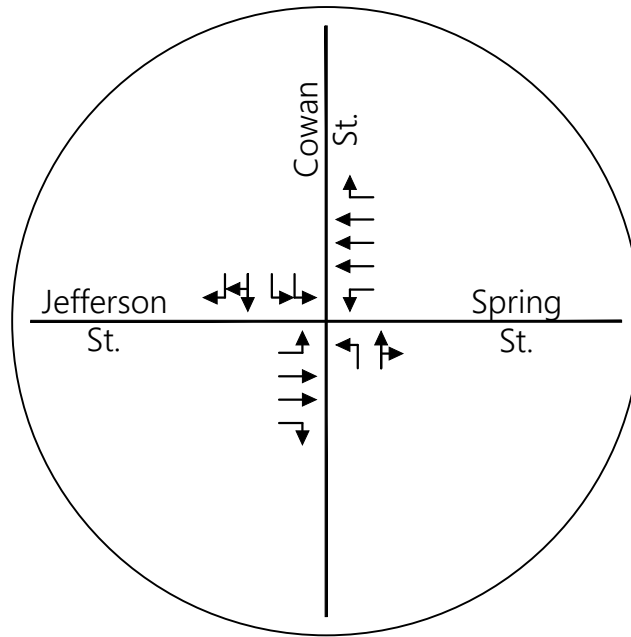

TOTAL PROJECTED TRAFFIC VOLUMES  
OPTION 1C

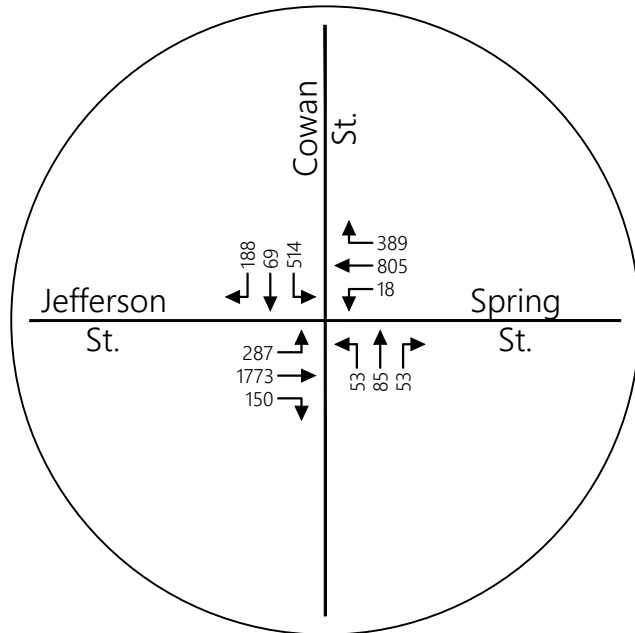

TOTAL PROJECTED TRAFFIC VOLUMES  
OPTION 2C

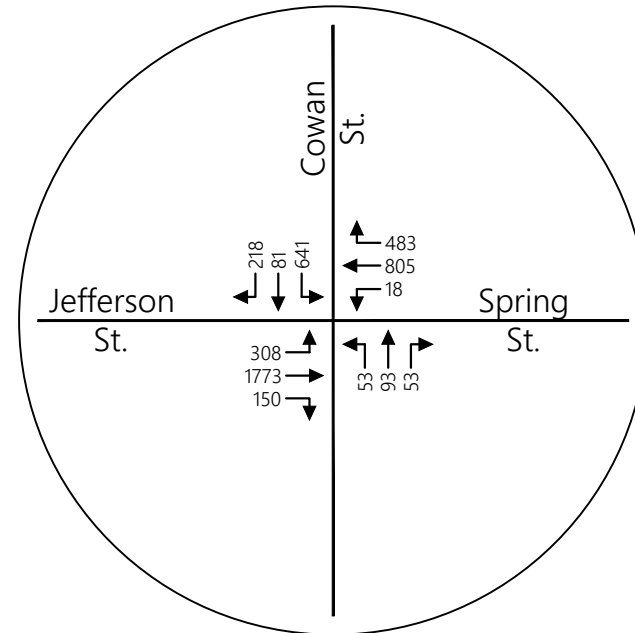

TOTAL PROJECTED TRAFFIC VOLUMES  
OPTION 3C

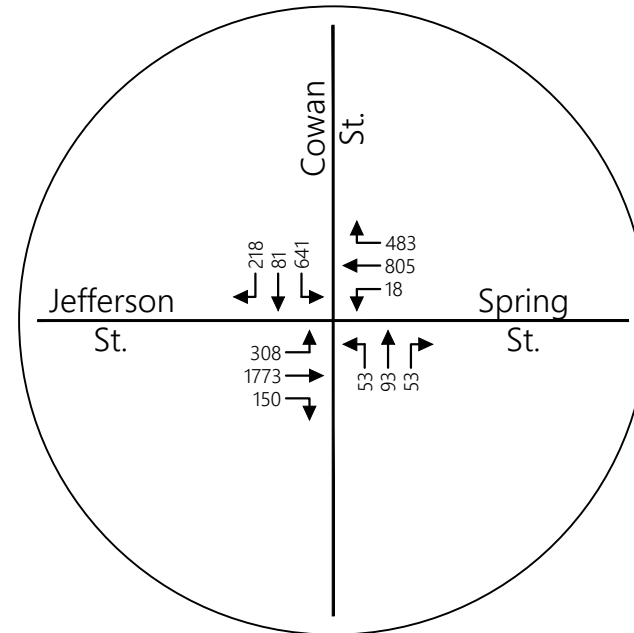

TOTAL PROJECTED TRAFFIC VOLUMES  
OPTION 4C

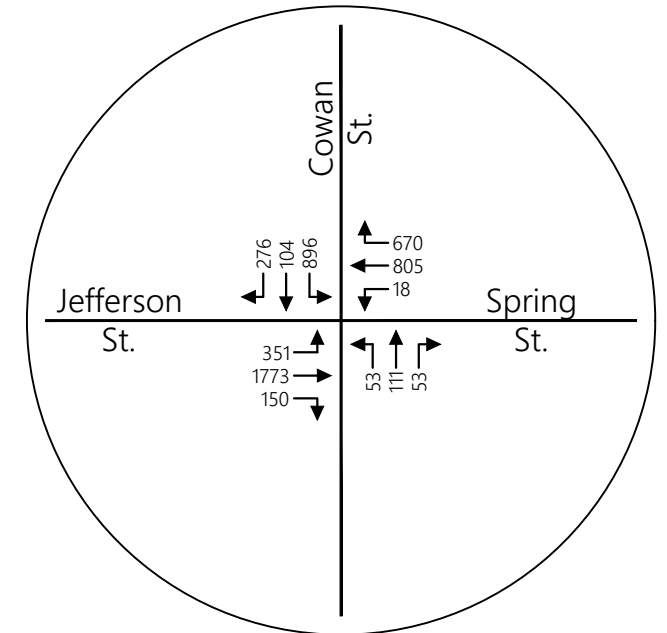

XXX - PM Peak Hour  
Traffic Volumes



Total Projected Peak Hour Traffic Volumes (High-Level Improvements - C)  
(Not to Scale)

Figure 15.

## 5. CONCLUSIONS AND RECOMMENDATIONS

A review was conducted of the roadway extensions, bridges and interstate access connections that are proposed as part of the River North master plan. This review consisted of evaluating the concepts based on federal and state requirements for the proposed new and modified interchanges and ramps and considering the improvements to network capacity and accessibility that would result with these concepts. Sensitivity analyses were also conducted to estimate the maximum expected newly generated trips by the proposed development, which can be managed by implementing those conceptual improvements within different stages. The suggested improvements are categorized as Low Level, Medium Level, and High Level. Conclusions of the reviews are as follows:

- The Cleveland Street extension and a connection across I-24 make a significant connection to the East Nashville area and will provide access to Dickerson Pike, Whites Creek Pike, Ellington Parkway (US 31E) and Gallatin Pike. Cleveland Street has a four-lane cross-section from Dickerson Pike to east of Ellington Parkway. Utilizing the highest PM peak hour trip generation (Option 4B) and the associated distribution, the Cleveland Street extension has the potential to add approximately 1,000 PM peak hour trips along the corridor; this serves as a significant increase over the 9,000 vpd currently served by the corridor. There are currently two (2) all-way stop controlled intersections along this portion of Cleveland Street, located at Meridian Street and Lischey Avenue. Improvements will likely be necessary at these intersections, at the Ellington Parkway ramps, and potentially at other intersections along the corridor when the Cleveland Street extension is constructed.
- Previous versions of the River North master plan included new on and off ramps to I-65 and I-24. Interchange modifications and/or new connections to the interstate system require both state and federal approval and there are strict standards regarding minimum spacing between ramps that must be met in order to obtain the necessary approvals. State and federal approval of any new interstate access is likely to require considerable modifications to the existing interchanges including the employment of one or more strategies to eliminate weaving on the interstate. These strategies include the addition of collector-distributor roads or grade separated ramps (ramp braids). Requirements for these type of freeway modifications are described in the NCHRP 687 report, *Guidelines for Ramp and Interchange Spacing*. Specific details regarding the operations and feasibility of any interchange modifications or additional access



points will need to be evaluated more thoroughly before understanding the feasibility of such improvements.

- The two proposed bridges over the Cumberland River have the potential to significantly improve access and provide alternative routes that would help lessen the impact of the project on the interstate system and on Jefferson Street/Spring Street. The current master plan illustrates the northern bridge as a vehicular and multimodal bridge and the southern bridge as a pedestrian and bicycle only bridge. It would be desirable for at least one of these bridges to have significant transit carrying capabilities.
- Consideration should be given to connecting the northern Cumberland River bridge to 3<sup>rd</sup> Avenue as well to provide more accessibility to and from north Nashville.
- A potential connection to Oldham Street has been discussed during the development of the masterplan. This connection would create a new north/south connection for project related traffic that may relieve development related traffic at the intersection of Jefferson Street/Spring Street and Cowan Street. The effectiveness of this connection could be further supported by improvements to South 1<sup>st</sup> Street, which provides access to Woodland Street to the south.
- The Grace Street extension and a connection across I-24 will provide a convenient connection to East Nashville and to Meridian Street, a north/south collector street. In addition, the Grace Street extension has the potential to be a strong bicycle/pedestrian connection to the pedestrian/bicycle bridge over Ellington Parkway. It should be noted that this proposed improvement was not included in the capacity analysis, for the purpose of this study. It was assumed that a portion of the distributed traffic on Cleveland Street connector would be distributed onto the Grace Street extension, which would result in the same reduction of traffic on Jefferson Street/Spring Street as without the implementation of this improvement.
- As previously described, the maximum full buildout of the southern 40 acres of the development is referred to as Phase 1 in this study. Improvement recommendations at the existing intersection of Jefferson Street/Spring Street and Cowan Street associated with Phase 1 of the development were also evaluated and are described below.

- Add additional turning lanes at the intersection of Jefferson Street and Cowan Street such that southbound Cowan Street consists of two or three left-turn lanes, a shared through/right lane and a right-turn lane. Further, an additional westbound lane will enhance capacity at this intersection. A right-turn lane with sufficient storage is recommended on the eastbound approach of Jefferson Street as well. It may be necessary to widen the eastern portion of the Jefferson Street bridge in order to add the recommended eastbound lane along Jefferson Street. Other feasible alternatives which may not require the widening of the bridge in order to accommodate additional eastbound travel lane, should also be considered and analyzed.
- The results of capacity analyses indicated that with low-level roadway improvements within the study area as described in the evaluation section, approximately 22% of the newly generated Phase 1 trips can be accommodated by the study area roadway system. Maximizing the density within the River North development is best accommodated with the high-level roadway improvements described previously in this study. Those improvements include the proposed new connectors/bridges with partial movement accesses to I-24 and/or I-65, providing additional eastbound travel lane on Jefferson Street and the I-24 bridge over Spring Street, and additional turning lanes on Cowan Street at Jefferson Street/Spring Street. It is estimated that 133% of the PM peak hour (5,940 vehicles per hour) for Phase 1 can be accommodated by implementing those improvements.
- It should be noted that intersections along Jefferson Street/Spring Street within the study area currently operate at or near capacity during peak hours. Therefore, improving the operational performance and traffic flow of Jefferson Street/Spring Street within the study area is warranted as of today even without the completion of any stages of River North development. Any development along the east bank is likely to exacerbate this existing need and access and capacity improvements will be needed to provide adequate traffic operations within the study area.
- It should be noted that the thresholds of development identified in this study are based on trips that are projected to be generated by the development of the River North project. As the development of River North progresses, the land uses and sizes that are actually developed may be different than those assumed for this study. If this occurs, continuing to use PM peak hour trips as

the warranting criteria for improvements will be an effective way to ensure that the recommended improvements are provided when needed.

- The evaluation of the proposed improvements and estimation of the maximum newly generated trips for the proposed development under each phase can be used as a helpful tool to plan different stages of the development. However, the capacity analysis procedure used in this study was based on several assumptions. It is recommended that the development conduct traffic counts as certain portions of the development is being completed and occupied in order to identify actual trip generation for the developed portions of the River North development. Those counts will provide a stronger foundation to verify the assumptions made in this study and also to explore further improvements using the actual travel patterns in and out of the development.
- It is important to note that traffic impact assumptions in this study are conservative, meaning analyses of network impacts were limited to the immediate vicinity of the development. Given the site's size and location adjacent to downtown and critical regional roadway junctions, , impacts (positive or negative) will occur well beyond the site. Should more robust high-level improvements be constructed, such as additional bridge connections or interstate improvements, functionality of the greater network in this area may in fact improve. Neither TDOT nor Metro Nashville has significant infrastructure improvements planned for the near term in this area, and while new trips will be added, these potential high-level improvements could provide alternative connections in the downtown area.
- Higher density for the proposed development may be achieved by emphasizing ride-share, and public transportation. Based on Mayor Barry's Transportation Action Agenda (Moving the Music City) plan, Metro Nashville, in partnership with TDOT, is developing a plan called Nashville Complete Trips. As part of the plan, Metro will promote other modes of transportation by reaching out to major employers and connecting employers and commuters to information about transportation options such as the transit and bikeshare systems, flex-scheduling and telecommuting, bike parking, and MTA/RTA park-and-ride locations. This plan would provide more opportunities for public-private partnerships by the proposed development. Such partnerships could be accomplished by providing private ride-share vehicles and/or sponsoring public transportation commutes for the employees. Upon the success of sponsoring other modes of commute, higher density for the proposed development could potentially be achieved with less traffic impacts on the roadway system.

APPENDICES

APPENDIX A

PRELIMINARY SITE PLAN

APPENDIX B

DETAILED TURNING MOVEMENT COUNTS

APPENDIX C

TDOT COUNT DATA

APPENDIX D

CAPACITY ANALYSES

APPENDIX E

TRIP GENERATION CALCULATIONS

APPENDICES

APPENDIX A

PRELIMINARY SITE PLAN

APPENDIX B

DETAILED TURNING MOVEMENT COUNTS

APPENDIX C

TDOT COUNT DATA

APPENDIX D

CAPACITY ANALYSES

APPENDIX E

TRIP GENERATION CALCULATIONS

APPENDIX A  
PRELIMINARY SITE PLAN

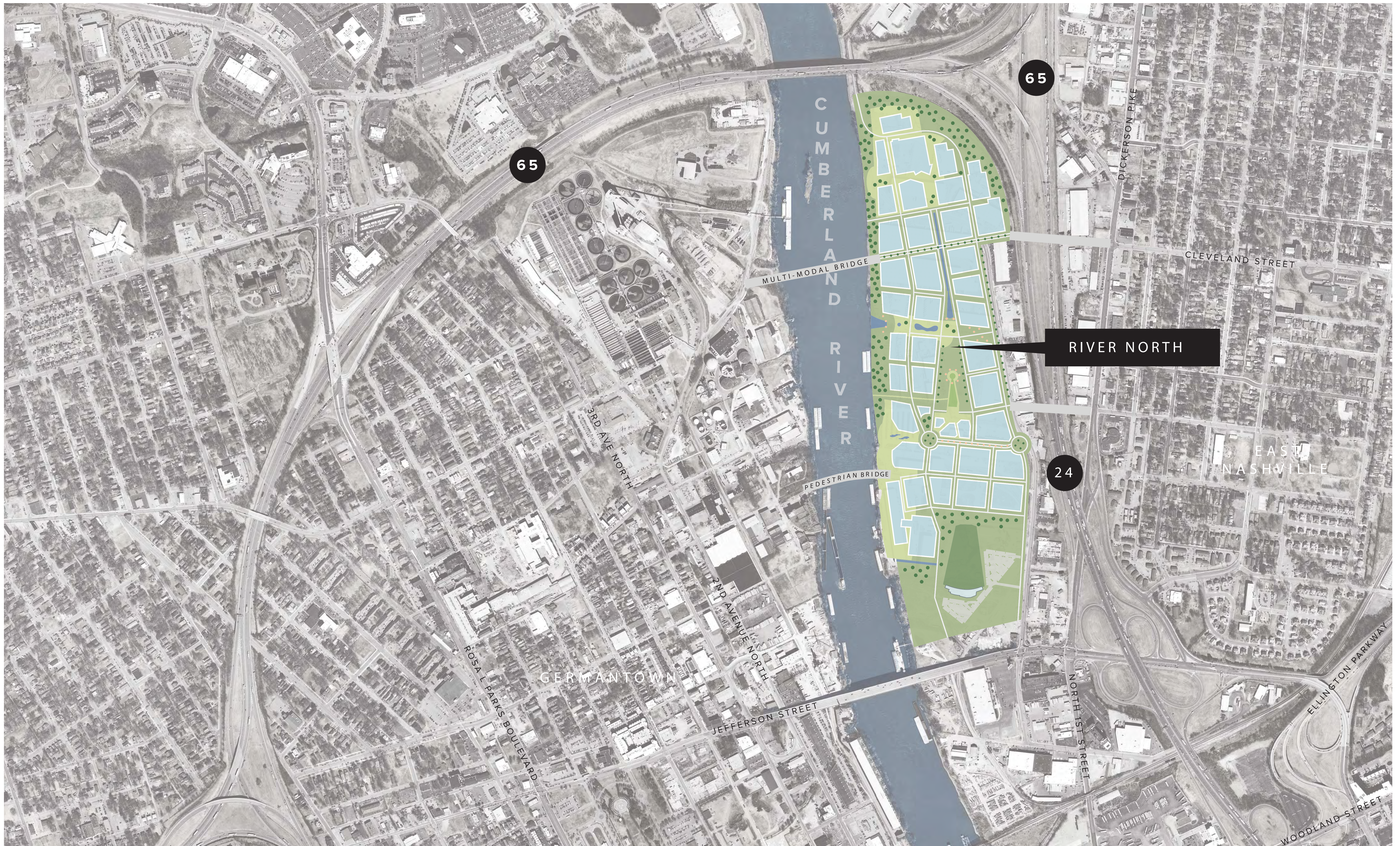

# LANDINGS

AT RIVERNORTH



PAD	PARCEL SIZE	GROSS BUILDABLE AREA (SF)	OFFICE (GROSS SF)	RESIDENTIAL (UNITS)	HOTEL (ROOMS)	RETAIL (SF)	NOTES
A	+/- 2.4 AC	524,000	456,000			68,000	RETROFIT FOR RESTAURANTS, ENTERTAINMENT, EXPANDABLE TO ADD OTHER USES
B	+/- 1.5 AC	327,000		310		25,000	
C	+/- 2.2 AC	480,000	455,000			25,000	
D	+/- 1.8 AC	393,000		250	150	20,000	
E	+/- 3.1 AC	720,000		460	250		
F	+/- 1.6 AC	458,000	368,000			90,000	RETAIL, OFFICE
G	+/- 1.4 AC	306,000	150,000	90	150	20,000	
H	+/- 1.2 AC	262,000		250		10,000	
I	+/- 1.8 AC	395,000	395,000				
J	+/- 1.9 AC	415,000		375			
K	+/- 1.9 AC	415,000	415,000				
L	+/- 1.6 AC	350,000	350,000				
M	+/- 1.9 AC	415,000	415,000				
TOTALS	+/- 24.3 AC	5,460,000	3,029,000	1,735	550	258,000	



APPENDIX B  
DETAILED TURNING MOVEMENT COUNTS



INTERSECTION TRAFFIC VOLUME COUNTS

LOCATION: Dickerson Pike & Spring Street  
 DATE: 9/20/2016  
 RECORDER: SCU3FB/Zack Murphy  
 NOTES:

LOCATION TIME	Southbound Dickerson Pike			Northbound Dickerson Pike			Westbound Spring Street			Eastbound Spring Street		
	1	2	3	4	5	6	7	8	9	10	11	12
6:00-6:15 AM												
6:15-6:30												
6:30-6:45												
6:45-7:00												
7:00-7:15	20		59				1	434	58	12	110	31
7:15-7:30	25		102					454	43	15	116	29
7:30-7:45	31		101					443	50	18	122	27
7:45-8:00	40		106					467	43	24	141	24
8:00-8:15	42		112					397	54	20	102	34
8:15-8:30	31		100					424	45	18	83	21
8:30-8:45	24		88					436	45	14	80	31
8:45-9:00	11		46					417	58	13	111	27
9:00-9:15												
9:15-9:30												
9:30-9:45												
9:45-10:00												
10:00-10:15												
10:15-10:30												
10:30-10:45												
10:45-11:00												
11:00-11:15												
11:15-11:30												
11:30-11:45												
11:45-12:00 PM												
12:00-12:15												
12:15-12:30												
12:30-12:45												
12:45-1:00												
1:00-1:15												
1:15-1:30												
1:30-1:45												
1:45-2:00												
2:00-2:15												
2:15-2:30												
2:30-2:45												
2:45-3:00												
3:00-3:15												
3:15-3:30												
3:30-3:45												
3:45-4:00												
4:00-4:15	25		30					227	111	31	283	44
4:15-4:30	19		34					213	116	28	271	38
4:30-4:45	26		35					234	113	40	268	46
4:45-5:00	31		40					206	127	45	282	52
5:00-5:15	25		30					202	156	44	262	54
5:15-5:30	18		21				1	203	162	49	280	37
5:30-5:45	16		38					182	138	41	233	35
5:45-6:00	18		36					196	118	52	256	19
6:00-6:15												
6:15-6:30												
6:30-6:45												
6:45-7:00												
7:00-7:15												
7:15-7:30												
7:30-7:45												
7:45-8:00												
8:00-8:15												
8:15-8:30												
8:30-8:45												
8:45-9:00												
9:00-9:15												
9:15-9:30												
9:30-9:45												
9:45-10:00 PM												
<b>TOTAL</b>	392		957				2	5,135	1,435	462	3,020	539
<b>AM PK HR</b>	138		421					1,761	190	75	481	104
<b>MID PK HR</b>												
<b>PM PK HR</b>	90		126				1	845	568	178	1,092	189

726  
1,509  
2,299  
3,144  
3,170  
3,118  
3,037  
2,875  
2,124  
1,392  
683

761  
1,470  
2,232  
3,005  
3,027  
3,079  
2,998  
2,918  
2,145  
1,374  
696

7:15 AM - 8:15 AM

4:30 PM - 5:30 PM

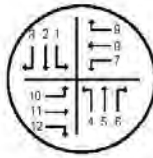

INTERSECTION TRAFFIC VOLUME COUNTS

LOCATION: North 1st Street & Jefferson Street  
 DATE: 9/20/2016  
 RECORDER: 8CU4XC/Zack Murphy  
 NOTES:

LOCATION	Southbound			Northbound			Westbound			Eastbound		
	North 1st Street			North 1st Street			Jefferson Street			Jefferson Street		
TIME	1	2	3	4	5	6	7	8	9	10	11	12
6:00-6:15 AM												
6:15-6:30												
6:30-6:45												
6:45-7:00												
7:00-7:15	67	83	150	12	18	16	16	238	4	26	139	10
7:15-7:30	64	84	153	7	28	28	16	259	2	20	151	8
7:30-7:45	65	106	136	15	20	26	11	255	4	23	168	19
7:45-8:00	65	100	109	21	24	23	13	329	1	27	161	27
8:00-8:15	54	93	127	15	22	25	17	281	6	27	145	20
8:15-8:30	60	128	128	16	31	30	26	274	5	24	132	17
8:30-8:45	47	82	96	13	24	29	26	254	5	25	143	17
8:45-9:00	62	55	93	25	28	23	17	211	3	43	140	6
9:00-9:15												
9:15-9:30												
9:30-9:45												
9:45-10:00												
10:00-10:15												
10:15-10:30												
10:30-10:45												
10:45-11:00												
11:00-11:15												
11:15-11:30												
11:30-11:45												
11:45-12:00 PM												
12:00-12:15												
12:15-12:30												
12:30-12:45												
12:45-1:00												
1:00-1:15												
1:15-1:30												
1:30-1:45												
1:45-2:00												
2:00-2:15												
2:15-2:30												
2:30-2:45												
2:45-3:00												
3:00-3:15												
3:15-3:30												
3:30-3:45												
3:45-4:00												
4:00-4:15	26	34	42	24	79	32	10	148	17	117	362	5
4:15-4:30	35	32	57	30	116	48	20	128	13	133	327	4
4:30-4:45	25	41	48	28	94	68	19	169	31	129	336	4
4:45-5:00	26	43	45	33	95	33	13	183	16	159	375	6
5:00-5:15	27	49	41	22	111	47	23	161	10	150	325	10
5:15-5:30	21	43	50	29	105	47	11	157	20	141	311	14
5:30-5:45	21	49	40	32	96	24	14	157	27	113	264	9
5:45-6:00	23	38	46	17	74	21	12	146	16	102	287	10
6:00-6:15												
6:15-6:30												
6:30-6:45												
6:45-7:00												
7:00-7:15												
7:15-7:30												
7:30-7:45												
7:45-8:00												
8:00-8:15												
8:15-8:30												
8:30-8:45												
8:45-9:00												
9:00-9:15												
9:15-9:30												
9:30-9:45												
9:45-10:00 PM												
TOTAL	688	1,059	1,367	340	966	520	264	3,300	109	1,258	3,796	188
AM PK HR	248	383	525	58	94	102	57	1,124	13	97	625	74
MID PK HR												
PM PK HR	99	175	184	113	408	195	86	620	68	579	1,347	34

760  
 1,600  
 2,448  
 3,348  
 3,400  
 3,451  
 3,364  
 3,172  
 2,340  
 1,469  
 708

916  
 1,859  
 2,850  
 3,826  
 3,899  
 3,904  
 3,784  
 3,588  
 2,602  
 1,654  
 802

7:15 AM - 8:15 AM  
 4:30 PM - 5:30 PM

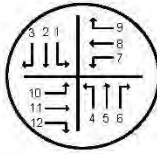

INTERSECTION TRAFFIC VOLUME COUNTS

LOCATION: Cowan Street & Jefferson Street  
 DATE: 9/20/2016  
 RECORDER: SCU5DA/Zack Murphy  
 NOTES:

LOCATION TIME	Southbound Cowan Street			Northbound Cowan Street			Westbound Jefferson Street			Eastbound Jefferson Street		
	1	2	3	4	5	6	7	8	9	10	11	12
6:00-6:15 AM												
6:15-6:30												
6:30-6:45												
6:45-7:00												
7:00-7:15	45	13	76	5	2	5	3	361	40	11	128	6
7:15-7:30	48	13	72	1	5	2	5	420	28	12	139	4
7:30-7:45	52	10	133	4	1	4	4	401	29	16	136	12
7:45-8:00	60	11	128	4	1	4	2	435	37	12	166	11
8:00-8:15	44	10	108	4	3	7		439	30	15	138	12
8:15-8:30	51	15	79	6	6	5	5	381	36	15	131	18
8:30-8:45	40	10	73	6	3	12	19	375	37	17	123	14
8:45-9:00	44	11	64	6	1	5	16	284	43	16	139	12
9:00-9:15												
9:15-9:30												
9:30-9:45												
9:45-10:00												
10:00-10:15												
10:15-10:30												
10:30-10:45												
10:45-11:00												
11:00-11:15												
11:15-11:30												
11:30-11:45												
11:45-12:00 PM												
12:00-12:15												
12:15-12:30												
12:30-12:45												
12:45-1:00												
1:00-1:15												
1:15-1:30												
1:30-1:45												
1:45-2:00												
2:00-2:15												
2:15-2:30												
2:30-2:45												
2:45-3:00												
3:00-3:15												
3:15-3:30												
3:30-3:45												
3:45-4:00												
4:00-4:15	30	11	30	6	17	14	9	183	52	46	461	25
4:15-4:30	21	16	21	5	10	13	3	197	24	63	442	32
4:30-4:45	46	12	25	14	12	11	7	199	33	62	421	32
4:45-5:00	42	11	27	16	16	14	5	190	30	55	460	44
5:00-5:15	30	8	26	10	15	18	2	199	25	56	456	41
5:15-5:30	15	3	23	13	16	10	4	217	20	49	436	33
5:30-5:45	23	4	18	5	6	11	3	206	26	41	378	19
5:45-6:00	13	6	17	3		10	4	184	13	32	353	17
6:00-6:15												
6:15-6:30												
6:30-6:45												
6:45-7:00												
7:00-7:15												
7:15-7:30												
7:30-7:45												
7:45-8:00												
8:00-8:15												
8:15-8:30												
8:30-8:45												
8:45-9:00												
9:00-9:15												
9:15-9:30												
9:30-9:45												
9:45-10:00 PM												
TOTAL	604	164	920	108	114	145	91	4,671	503	518	4,507	332
AM PK HR	204	44	441	13	10	17	11	1,695	124	55	579	39
MID PK HR												
PM PK HR	133	34	101	53	59	53	18	805	108	222	1,773	150

695  
1,444  
2,246  
3,117  
3,232  
3,231  
3,158  
2,928  
2,118  
1,370  
641

884  
1,731  
2,606  
3,616  
3,617  
3,609  
3,376  
3,117  
2,231  
1,392  
652

7:15 AM - 8:15 AM

4:30 PM - 5:30 PM



INTERSECTION TRAFFIC VOLUME COUNTS

LOCATION: Dickerson Pike & Spring Street  
 DATE: 9/20/2016  
 RECORDER: SCUSFBIZack Murphy  
 NOTES:

LOCATION TIME	Southbound Dickerson Pike			Northbound Dickerson Pike			Westbound Spring Street			Eastbound Spring Street		
	1	2	3	4	5	6	7	8	9	10	11	12
6:00-6:15 AM												
6:15-6:30												
6:30-6:45												
6:45-7:00												
7:00-7:15	20		59				1	434	55	12	110	31
7:15-7:30	25		102					454	43	15	116	29
7:30-7:45	31		101					443	50	10	122	27
7:45-8:00	40		106					467	43	24	141	24
8:00-8:15	42		112					397	54	20	102	24
8:15-8:30	31		100					474	45	18	93	21
8:30-8:45	24		99					436	45	14	90	31
8:45-9:00	11		46					417	58	13	111	27
9:00-9:15												
9:15-9:30												
9:30-9:45												
9:45-10:00												
10:00-10:15												
10:15-10:30												
10:30-10:45												
10:45-11:00												
11:00-11:15												
11:15-11:30												
11:30-11:45												
11:45-12:00 PM												
12:00-12:15												
12:15-12:30												
12:30-12:45												
12:45-1:00												
1:00-1:15												
1:15-1:30												
1:30-1:45												
1:45-2:00												
2:00-2:15												
2:15-2:30												
2:30-2:45												
2:45-3:00												
3:00-3:15												
3:15-3:30												
3:30-3:45												
3:45-4:00												
4:00-4:15	25		30					227	111	31	283	44
4:15-4:30	19		34					213	116	28	271	38
4:30-4:45	26		35					234	114	40	268	46
4:45-5:00	21		40					206	127	45	262	52
5:00-5:15	25		30					202	156	44	262	54
5:15-5:30	18		21				1	203	162	48	280	37
5:30-5:45	16		36					162	136	41	233	35
5:45-6:00	18		36					196	119	52	256	19
6:00-6:15												
6:15-6:30												
6:30-6:45												
6:45-7:00												
7:00-7:15												
7:15-7:30												
7:30-7:45												
7:45-8:00												
8:00-8:15												
8:15-8:30												
8:30-8:45												
8:45-9:00												
9:00-9:15												
9:15-9:30												
9:30-9:45												
9:45-10:00 PM												
<b>TOTAL</b>	392		957				2	5,135	1,435	462	3,020	539
<b>AM PK HR</b>	138		421					1,761	190	75	451	104
<b>MID PK HR</b>												
<b>PM PK HR</b>	80		126				1	845	550	176	1,092	189

725  
1,509  
2,299  
3,144  
3,170  
3,118  
3,037  
2,875  
2,124  
1,392  
683

761  
1,470  
2,232  
3,005  
3,027  
3,079  
2,996  
2,918  
2,145  
1,374  
695

7:15 AM - 8:15 AM  
4:30 PM - 5:30 PM

APPENDIX C  
TDOT COUNT DATA

## Station Information

Station	000315
Route	I0065
Location	[LOOPS] NASHVILLE
County	Davidson
2016	93453
2015	103738
2014	97381
2013	90804
2012	95882
2011	94309
2010	97235
2009	95364
2008	93222
2007	103115
2006	96998
2005	95853
2004	92334
2003	92746
2002	88952
2001	88756
2000	72471
1999	71002
1998	63474
1997	78111
1996	80782
1995	75045
1994	71493
1993	87432
1992	77718
1991	64934
1990	61368
1989	65028
1988	67146
1987	75000
1986	74018
1985	57516
1984	NA
1983	NA

## Station Information

Station	000053
Route	SR011
Location	N OF JEFERSON ST BRIDGE
County	Davidson
2016	18903
2015	17557
2014	16205
2013	16362
2012	16008
2011	15595
2010	15429
2009	18698
2008	17447
2007	18969
2006	20698
2005	20184
2004	22680
2003	21955
2002	21516
2001	21112
2000	21826
1999	21653
1998	24912
1997	22000
1996	19840
1995	25646
1994	16286
1993	14296
1992	16759
1991	28340
1990	22541
1989	26548
1988	28282
1987	21535
1986	21599
1985	19097
1984	NA
1983	NA



## Station Information

Station	000389
Route	04915
Location	EASTLAND - SW OF 388
County	Davidson
2016	9309
2015	9432
2014	8930
2013	7716
2012	7171
2011	7328
2010	7252
2009	7961
2008	7729
2007	8117
2006	8801
2005	8623
2004	9725
2003	9765
2002	10454
2001	10692
2000	10546
1999	10134
1998	10525
1997	12373
1996	12468
1995	11051
1994	10772
1993	11402
1992	9639
1991	8340
1990	9220
1989	9285
1988	10062
1987	10005
1986	10498
1985	9926
1984	NA
1983	NA

## Station Information

Station	000304
Route	SR006
Location	ELLINGTON PKWY - NASHVILLE
County	Davidson
2016	50255
2015	50371
2014	46513
2013	45282
2012	42915
2011	40692
2010	41316
2009	38007
2008	42233
2007	44400
2006	39093
2005	46319
2004	45875
2003	45418
2002	42341
2001	39381
2000	37385
1999	43710
1998	45690
1997	42037
1996	40757
1995	41146
1994	39959
1993	34825
1992	31816
1991	32874
1990	35477
1989	36798
1988	34849
1987	34485
1986	35573
1985	27535
1984	NA
1983	NA

## Station Information

Station	000387
Route	04915
Location	EASTLAND - N OF GALLATIN RD
County	Davidson
2016	6476
2015	6489
2014	6265
2013	6203
2012	6339
2011	5818
2010	5618
2009	5755
2008	6020
2007	5875
2006	5629
2005	6184
2004	6790
2003	6685
2002	7884
2001	7798
2000	6328
1999	6968
1998	8187
1997	9124
1996	6463
1995	7957
1994	6075
1993	5493
1992	6500
1991	6470
1990	6329
1989	5547
1988	6408
1987	6576
1986	5468
1985	5864
1984	NA
1983	NA

## Station Information

Station	000224
Route	SR006
Location	ELLINGTON PKWY-E OF SPRING ST
County	Davidson
2016	41246
2015	46791
2014	45829
2013	44726
2012	43117
2011	41325
2010	41129
2009	37709
2008	42033
2007	42230
2006	47602
2005	46597
2004	45916
2003	45454
2002	42514
2001	44231
2000	37966
1999	43188
1998	48124
1997	41792
1996	41569
1995	39028
1994	39115
1993	35933
1992	38096
1991	36281
1990	44593
1989	42994
1988	39707
1987	36574
1986	31942
1985	27608
1984	NA
1983	NA

## Station Information

Station	000223
Route	SR011
Location	NEAR JEFFERSON ST BRIDGE
County	Davidson
2016	5437
2015	4443
2014	4397
2013	4337
2012	4303
2011	4153
2010	3954
2009	4154
2008	4033
2007	4002
2006	3578
2005	3719
2004	4246
2003	3993
2002	4096
2001	3967
2000	4293
1999	4303
1998	4611
1997	4533
1996	6014
1995	5724
1994	5362
1993	6632
1992	5809
1991	5021
1990	6824
1989	6491
1988	5391
1987	5305
1986	5249
1985	4639
1984	NA
1983	NA

## Station Information

Station	000300
Route	I0024
Location	[LOOPS] N OF MAIN ST
County	Davidson
2016	112585
2015	111471
2014	106517
2013	111467
2012	102166
2011	98292
2010	100916
2009	94330
2008	102899
2007	104740
2006	107073
2005	103884
2004	104700
2003	102898
2002	100955
2001	93684
2000	109108
1999	106372
1998	95515
1997	104550
1996	106939
1995	101150
1994	97873
1993	96369
1992	74169
1991	94591
1990	81165
1989	77000
1988	75000
1987	73843
1986	63000
1985	56584
1984	NA
1983	NA

## Station Information

Station	000422
Route	03262
Location	3RD AVE N - NEAR I- 65 LOOP
County	Davidson
2016	6143
2015	5965
2014	4992
2013	6046
2012	5874
2011	6173
2010	6203
2009	6444
2008	6600
2007	6497
2006	6669
2005	6388
2004	5807
2003	5240
2002	4971
2001	5609
2000	5818
1999	5655
1998	6507
1997	4724
1996	6300
1995	6886
1994	5615
1993	5834
1992	5523
1991	5600
1990	5412
1989	5417
1988	5263
1987	5817
1986	5095
1985	5489
1984	NA
1983	NA

## Station Information

Station	000054
Route	SR012
Location	BETWEEN GARFIELD & HUONE
County	Davidson
2016	18100
2015	16877
2014	15329
2013	15980
2012	15088
2011	13575
2010	15577
2009	14619
2008	16223
2007	16673
2006	17369
2005	17433
2004	17169
2003	16450
2002	16472
2001	16346
2000	16651
1999	18127
1998	16435
1997	17786
1996	17583
1995	19397
1994	19713
1993	16156
1992	18345
1991	12821
1990	11934
1989	13510
1988	15975
1987	13146
1986	10792
1985	7992
1984	NA
1983	NA



## Station Information

Station	000390
Route	NA
Location	2ND AVE. N. - NEAR JEFFERSON ST
County	Davidson
2016	6119
2015	6262
2014	5722
2013	5754
2012	5350
2011	5976
2010	5543
2009	5885
2008	5876
2007	5829
2006	5774
2005	5708
2004	5038
2003	5504
2002	5226
2001	5163
2000	5107
1999	5120
1998	4922
1997	5406
1996	5309
1995	5953
1994	2327
1993	4310
1992	4300
1991	4294
1990	3671
1989	4301
1988	4140
1987	5486
1986	3578
1985	4070
1984	NA
1983	NA

## Station Information

Station	000074
Route	03258
Location	JEFFERSON ST BRIDGE
County	Davidson
2016	31635
2015	31203
2014	29320
2013	27923
2012	28299
2011	27571
2010	26851
2009	24562
2008	28511
2007	30169
2006	30722
2005	31547
2004	32265
2003	30221
2002	31550
2001	32233
2000	30563
1999	35288
1998	38609
1997	33561
1996	28849
1995	30268
1994	NA
1993	NA
1992	24000
1991	23317
1990	18628
1989	22363
1988	23614
1987	26263
1986	22564
1985	26529
1984	NA
1983	NA

## Station Information

Station	000393
Route	0F718
Location	5TH AVE. N. - INSIDE NASHVILLE LOOP
County	Davidson
2016	2979
2015	2874
2014	3059
2013	2748
2012	2406
2011	2595
2010	2707
2009	2816
2008	3025
2007	3107
2006	3359
2005	3352
2004	3302
2003	3210
2002	3088
2001	2921
2000	3083
1999	3342
1998	3188
1997	3041
1996	2190
1995	2115
1994	2361
1993	2937
1992	2910
1991	2841
1990	2903
1989	3700
1988	3614
1987	3459
1986	3336
1985	4393
1984	NA
1983	NA

## Station Information

Station	000391
Route	03262
Location	3RD AVE - (ONE-WAY)
County	Davidson
2016	1957
2015	2000
2014	1928
2013	2020
2012	2138
2011	2092
2010	2199
2009	2013
2008	2652
2007	2575
2006	2560
2005	2765
2004	2738
2003	2651
2002	2541
2001	2646
2000	2808
1999	3996
1998	5557
1997	5543
1996	5398
1995	8095
1994	6550
1993	6064
1992	5711
1991	4437
1990	5005
1989	4862
1988	5280
1987	4678
1986	4802
1985	4451
1984	NA
1983	NA

## Station Information

Station	000154
Route	03266
Location	N FIRST ST-B/T WOODLAND & SPRING ST
County	Davidson
2016	9006
2015	9376
2014	8716
2013	8272
2012	8293
2011	8803
2010	8547
2009	11047
2008	9886
2007	11086
2006	12233
2005	11794
2004	13162
2003	12767
2002	11374
2001	10847
2000	11491
1999	13977
1998	13656
1997	16834
1996	14372
1995	20654
1994	16624
1993	13342
1992	13056
1991	10950
1990	13141
1989	14000
1988	13704
1987	15869
1986	16095
1985	16266
1984	NA
1983	NA

## Station Information

Station	000194
Route	I0024
Location	B/T SPRING ST & MAIN ST
County	Davidson
2016	129692
2015	131220
2014	124525
2013	129338
2012	117695
2011	115690
2010	117916
2009	107920
2008	116432
2007	118216
2006	120632
2005	117768
2004	115814
2003	115826
2002	112503
2001	105611
2000	121571
1999	112691
1998	108202
1997	119326
1996	122262
1995	112157
1994	112077
1993	103101
1992	76383
1991	98143
1990	88132
1989	96185
1988	82000
1987	80935
1986	67000
1985	60835
1984	NA
1983	NA

## Station Information

Station	000153
Route	03252
Location	NEAR WOODLAND ST BRIDGE
County	Davidson
2016	25719
2015	26927
2014	23787
2013	22081
2012	21122
2011	21843
2010	19634
2009	19349
2008	19326
2007	21059
2006	20697
2005	21889
2004	21320
2003	20284
2002	22555
2001	23039
2000	19467
1999	20946
1998	22388
1997	20995
1996	22653
1995	20092
1994	26974
1993	27569
1992	18783
1991	20304
1990	16573
1989	20742
1988	20026
1987	20439
1986	21656
1985	19142
1984	NA
1983	NA

## Station Information

Station	000220
Route	03244
Location	E OF I-65
County	Davidson
2016	7608
2015	7338
2014	7320
2013	7304
2012	7338
2011	7319
2010	7216
2009	7215
2008	7492
2007	7941
2006	8038
2005	8016
2004	9062
2003	8790
2002	9255
2001	9330
2000	8018
1999	9111
1998	8566
1997	9009
1996	8154
1995	15530
1994	11841
1993	8639
1992	8585
1991	8507
1990	8021
1989	4364
1988	8863
1987	8847
1986	8346
1985	9743
1984	NA
1983	NA



## Station Information

Station	000488
Route	03272
Location	5TH ST - N OF WOODLAND ST
County	Davidson
2016	16646
2015	16346
2014	16324
2013	15680
2012	15924
2011	14138
2010	14526
2009	17258
2008	15649
2007	16472
2006	17171
2005	16713
2004	16422
2003	15864
2002	14358
2001	15834
2000	16195
1999	16467
1998	19346
1997	15691
1996	19798
1995	19528
1994	16239
1993	14395
1992	13991
1991	NA
1990	NA
1989	NA
1988	NA
1987	NA
1986	NA
1985	NA
1984	NA
1983	NA

## Station Information

Station	000075
Route	SR006
Location	VIC MEM BRIDGE - CBD
County	Davidson
2016	28363
2015	28174
2014	25326
2013	24513
2012	23735
2011	23308
2010	23759
2009	23321
2008	23917
2007	23220
2006	23923
2005	25387
2004	25162
2003	27026
2002	26835
2001	27907
2000	30207
1999	28434
1998	40316
1997	24041
1996	31519
1995	32169
1994	32390
1993	29739
1992	29592
1991	27111
1990	24410
1989	24233
1988	25669
1987	24163
1986	31721
1985	22134
1984	NA
1983	NA

## Station Information

Station	000046
Route	03244
Location	WOODLAND ST - CBD
County	Davidson
2016	13823
2015	13811
2014	13388
2013	13239
2012	13137
2011	12333
2010	11817
2009	22087
2008	23335
2007	14758
2006	20569
2005	19970
2004	19393
2003	21435
2002	26960
2001	25451
2000	25835
1999	21649
1998	26950
1997	25374
1996	24547
1995	27518
1994	20116
1993	19896
1992	19272
1991	15639
1990	15682
1989	18300
1988	18255
1987	15194
1986	18314
1985	18206
1984	NA
1983	NA

## Station Information





















Station	000290
Route	I0024
Location	N OF SHELBY AVE
County	Davidson
2016	139532
2015	141434
2014	134002
2013	138277
2012	127367
2011	124211
2010	128164
2009	116164
2008	122101
2007	122710
2006	127482
2005	125224
2004	123065
2003	124196
2002	120150
2001	112752
2000	127612
1999	120841
1998	117474
1997	128593
1996	130289
1995	119324
1994	118514
1993	110401
1992	89409
1991	101606
1990	99930
1989	95067
1988	88141
1987	83000
1986	82000
1985	75000
1984	NA
1983	NA

APPENDIX D  
CAPACITY ANALYSES

EXISTING CONDITIONS  
CAPACITY ANALYSES























HCM 2010 Signalized Intersection Summary  
 1: Cowan Street & Jefferson Street/Spring Street

River North  
 Existing AM

												
Movement	EBL	EBT	EBR	WBL	WBT	WBR	NBL	NBT	NBR	SBL	SBT	SBR
Lane Configurations												
Traffic Volume (veh/h)	55	579	39	11	1695	124	13	10	17	204	44	441
Future Volume (veh/h)	55	579	39	11	1695	124	13	10	17	204	44	441
Number	1	6	16	5	2	12	7	4	14	3	8	18
Initial Q (Qb), veh	0	0	0	0	0	0	0	0	0	0	0	0
Ped-Bike Adj(A_pbT)	1.00		1.00	1.00		1.00	1.00		1.00	1.00		1.00
Parking Bus, Adj	1.00	1.00	1.00	1.00	1.00	1.00	1.00	1.00	1.00	1.00	1.00	1.00
Adj Sat Flow, veh/h/ln	1863	1863	1863	1863	1863	1900	1863	1863	1900	1863	1863	1900
Adj Flow Rate, veh/h	60	629	42	12	1842	135	14	11	18	222	48	479
Adj No. of Lanes	1	2	1	1	3	0	1	1	0	1	1	0
Peak Hour Factor	0.92	0.92	0.92	0.92	0.92	0.92	0.92	0.92	0.92	0.92	0.92	0.92
Percent Heavy Veh, %	2	2	2	2	2	2	2	2	2	2	2	2
Cap, veh/h	231	2212	990	486	2950	216	51	136	223	327	31	313
Arrive On Green	0.03	0.63	0.63	0.02	1.00	1.00	0.21	0.21	0.21	0.21	0.21	0.21
Sat Flow, veh/h	1774	3539	1583	1774	4837	353	872	637	1042	1375	146	1459
Grp Volume(v), veh/h	60	629	42	12	1289	688	14	0	29	222	0	527
Grp Sat Flow(s),veh/h/ln	1774	1770	1583	1774	1695	1800	872	0	1679	1375	0	1605
Q Serve(g_s), s	1.8	11.3	1.4	0.4	0.0	0.0	0.0	0.0	1.9	21.5	0.0	30.0
Cycle Q Clear(g_c), s	1.8	11.3	1.4	0.4	0.0	0.0	30.0	0.0	1.9	23.5	0.0	30.0
Prop In Lane	1.00		1.00	1.00		0.20	1.00		0.62	1.00		0.91
Lane Grp Cap(c), veh/h	231	2212	990	486	2068	1098	51	0	360	327	0	344
V/C Ratio(X)	0.26	0.28	0.04	0.02	0.62	0.63	0.27	0.00	0.08	0.68	0.00	1.53
Avail Cap(c_a), veh/h	287	2212	990	568	2068	1098	51	0	360	327	0	344
HCM Platoon Ratio	1.00	1.00	1.00	2.00	2.00	2.00	1.00	1.00	1.00	1.00	1.00	1.00
Upstream Filter(I)	1.00	1.00	1.00	0.69	0.69	0.69	1.00	0.00	1.00	1.00	0.00	1.00
Uniform Delay (d), s/veh	9.6	12.0	10.1	10.3	0.0	0.0	70.0	0.0	44.0	53.4	0.0	55.0
Incr Delay (d2), s/veh	0.2	0.3	0.1	0.0	1.0	1.9	1.0	0.0	0.0	4.6	0.0	253.6
Initial Q Delay(d3),s/veh	0.0	0.0	0.0	0.0	0.0	0.0	0.0	0.0	0.0	0.0	0.0	0.0
%ile BackOfQ(50%),veh/ln	0.9	5.6	0.6	0.2	0.3	0.6	0.6	0.0	0.9	8.6	0.0	37.5
LnGrp Delay(d),s/veh	9.8	12.3	10.2	10.3	1.0	1.9	71.0	0.0	44.0	58.0	0.0	308.6
LnGrp LOS	A	B	B	B	A	A	E		D	E		F
Approach Vol, veh/h		731			1989			43			749	
Approach Delay, s/veh		12.0			1.4			52.8			234.3	
Approach LOS		B			A			D			F	
Timer	1	2	3	4	5	6	7	8				
Assigned Phs	1	2		4	5	6		8				
Phs Duration (G+Y+Rc), s	10.6	92.4		37.0	8.5	94.5		37.0				
Change Period (Y+Rc), s	7.0	7.0		7.0	7.0	7.0		7.0				
Max Green Setting (Gmax), s	8.0	81.0		30.0	8.0	81.0		30.0				
Max Q Clear Time (g_c+I1), s	3.8	2.0		32.0	2.4	13.3		32.0				
Green Ext Time (p_c), s	0.0	10.5		0.0	0.0	10.5		0.0				
<b>Intersection Summary</b>												
HCM 2010 Ctrl Delay			53.9									
HCM 2010 LOS			D									
<b>Notes</b>												

HCM 2010 Signalized Intersection Summary  
2: N 1st Street & Spring Street

River North  
Existing AM

												
Movement	EBL	EBT	EBR	WBL	WBT	WBR	NBL	NBT	NBR	SBL	SBT	SBR
Lane Configurations												
Traffic Volume (veh/h)	97	625	74	57	1124	13	58	94	102	248	383	525
Future Volume (veh/h)	97	625	74	57	1124	13	58	94	102	248	383	525
Number	1	6	16	5	2	12	7	4	14	3	8	18
Initial Q (Qb), veh	0	0	0	0	0	0	0	0	0	0	0	0
Ped-Bike Adj(A_pbT)	1.00		1.00	1.00		1.00	1.00		1.00	1.00		1.00
Parking Bus, Adj	1.00	1.00	1.00	1.00	1.00	1.00	1.00	1.00	1.00	1.00	1.00	1.00
Adj Sat Flow, veh/h/ln	1863	1863	1900	1863	1863	1900	1863	1863	1863	1863	1863	1863
Adj Flow Rate, veh/h	105	679	80	62	1222	14	63	102	111	270	416	571
Adj No. of Lanes	2	2	0	1	2	0	1	2	1	1	1	2
Peak Hour Factor	0.92	0.92	0.92	0.92	0.92	0.92	0.92	0.92	0.92	0.92	0.92	0.92
Percent Heavy Veh, %	2	2	2	2	2	2	2	2	2	2	2	2
Cap, veh/h	226	1730	204	446	1907	22	144	362	162	336	293	498
Arrive On Green	0.13	1.00	1.00	0.05	0.53	0.53	0.05	0.10	0.10	0.11	0.16	0.16
Sat Flow, veh/h	3442	3191	376	1774	3584	41	1774	3539	1583	1774	1863	3167
Grp Volume(v), veh/h	105	376	383	62	603	633	63	102	111	270	416	571
Grp Sat Flow(s),veh/h/ln	1721	1770	1796	1774	1770	1856	1774	1770	1583	1774	1863	1583
Q Serve(g_s), s	4.0	0.0	0.0	2.6	33.9	33.9	4.4	3.7	9.5	15.5	22.0	17.8
Cycle Q Clear(g_c), s	4.0	0.0	0.0	2.6	33.9	33.9	4.4	3.7	9.5	15.5	22.0	17.8
Prop In Lane	1.00		0.21	1.00		0.02	1.00		1.00	1.00		1.00
Lane Grp Cap(c), veh/h	226	959	974	446	942	987	144	362	162	336	293	498
V/C Ratio(X)	0.46	0.39	0.39	0.14	0.64	0.64	0.44	0.28	0.69	0.80	1.42	1.15
Avail Cap(c_a), veh/h	226	959	974	493	942	987	153	379	170	336	293	498
HCM Platoon Ratio	2.00	2.00	2.00	1.00	1.00	1.00	1.00	1.00	1.00	1.00	1.00	1.00
Upstream Filter(I)	0.92	0.92	0.92	1.00	1.00	1.00	1.00	1.00	1.00	1.00	1.00	1.00
Uniform Delay (d), s/veh	58.5	0.0	0.0	18.4	23.2	23.3	52.6	58.1	60.7	50.8	59.0	38.5
Incr Delay (d2), s/veh	1.7	1.1	1.1	0.1	3.3	3.2	0.8	0.2	8.3	12.3	208.4	87.7
Initial Q Delay(d3),s/veh	0.0	0.0	0.0	0.0	0.0	0.0	0.0	0.0	0.0	0.0	0.0	0.0
%ile BackOfQ(50%),veh/ln	1.9	0.3	0.3	1.2	17.3	18.1	2.2	1.8	4.5	10.3	28.2	13.8
LnGrp Delay(d),s/veh	60.2	1.1	1.1	18.5	26.6	26.4	53.4	58.3	69.0	63.2	267.4	126.2
LnGrp LOS	E	A	A	B	C	C	D	E	E	E	F	F
Approach Vol, veh/h		864			1298			276			1257	
Approach Delay, s/veh		8.3			26.1			61.5			159.4	
Approach LOS		A			C			E			F	
Timer	1	2	3	4	5	6	7	8				
Assigned Phs	1	2	3	4	5	6	7	8				
Phs Duration (G+Y+Rc), s	15.7	81.0	22.0	21.3	14.3	82.4	14.3	29.0				
Change Period (Y+Rc), s	6.5	6.5	6.5	7.0	7.0	6.5	7.0	7.0				
Max Green Setting (Gmax), s	8.5	74.5	15.5	15.0	11.0	71.5	8.0	22.0				
Max Q Clear Time (g_c+I1), s	6.0	35.9	17.5	11.5	4.6	2.0	6.4	24.0				
Green Ext Time (p_c), s	0.1	2.9	0.0	1.5	0.0	2.2	0.0	0.0				
<b>Intersection Summary</b>												
HCM 2010 Ctrl Delay			69.9									
HCM 2010 LOS			E									
<b>Notes</b>												



# HCM Signalized Intersection Capacity Analysis

## 3: Spring Street & Dickerson Pike

River North  
Existing AM



Movement	EBL	EBT	EBR	WBL	WBT	WBR	SBL2	SBL	SBR	NWL	NWR
Lane Configurations											
Traffic Volume (vph)	75	481	104	0	1750	190	138	0	421	0	0
Future Volume (vph)	75	481	104	0	1750	190	138	0	421	0	0
Ideal Flow (vphpl)	1900	1900	1900	1900	1900	1900	1900	1900	1900	1900	1900
Total Lost time (s)	6.5	6.5	6.5		6.5	6.5	4.5		4.5		
Lane Util. Factor	1.00	0.95	1.00		0.91	0.91	1.00		1.00		
Frt	1.00	1.00	0.85		1.00	0.85	1.00		0.85		
Flt Protected	0.95	1.00	1.00		1.00	1.00	0.95		1.00		
Satd. Flow (prot)	1770	3539	1583		3385	1441	1770		1583		
Flt Permitted	0.04	1.00	1.00		1.00	1.00	0.95		1.00		
Satd. Flow (perm)	79	3539	1583		3385	1441	1770		1583		
Peak-hour factor, PHF	0.92	0.92	0.92	0.92	0.92	0.92	0.92	0.92	0.92	0.92	0.92
Adj. Flow (vph)	82	523	113	0	1902	207	150	0	458	0	0
RTOR Reduction (vph)	0	0	36	0	0	43	0	0	123	0	0
Lane Group Flow (vph)	82	523	77	0	1923	143	150	0	335	0	0
Turn Type	D.P+P	NA	custom		NA	Perm	Prot		Prot		
Protected Phases	1	2			2 3		4		4		
Permitted Phases	2 3	2 3	2 3			2 3					
Actuated Green, G (s)	101.0	89.2	95.7		95.7	95.7	23.5		23.5		
Effective Green, g (s)	101.0	89.2	95.7		95.7	95.7	23.5		23.5		
Actuated g/C Ratio	0.72	0.64	0.68		0.68	0.68	0.17		0.17		
Clearance Time (s)	6.5	6.5					4.5		4.5		
Vehicle Extension (s)	2.0	2.0					2.0		2.0		
Lane Grp Cap (vph)	121	2419	1082		2313	985	297		265		
v/s Ratio Prot	c0.03	0.13			c0.57		0.08		c0.21		
v/s Ratio Perm	0.47	0.01	0.05			0.10					
v/c Ratio	0.68	0.22	0.07		0.83	0.15	0.51		1.26		
Uniform Delay, d1	26.7	10.7	7.4		16.2	7.8	53.0		58.2		
Progression Factor	1.14	0.79	0.36		0.32	0.12	1.00		1.00		
Incremental Delay, d2	11.0	0.0	0.0		1.5	0.0	0.5		145.2		
Delay (s)	41.3	8.5	2.6		6.7	1.0	53.5		203.5		
Level of Service	D	A	A		A	A	D		F		
Approach Delay (s)		11.3			6.2			166.4		0.0	
Approach LOS		B			A			F		A	

### Intersection Summary

HCM 2000 Control Delay	35.6	HCM 2000 Level of Service	D
HCM 2000 Volume to Capacity ratio	0.96		
Actuated Cycle Length (s)	140.0	Sum of lost time (s)	22.0
Intersection Capacity Utilization	85.6%	ICU Level of Service	E
Analysis Period (min)	15		

c Critical Lane Group

# HCM Signalized Intersection Capacity Analysis

## 4: I-24 WB Off-Ramp & Spring Street

River North  
Existing AM



Movement	EBT	EBR	WBL	WBT	NBL	NBR
Lane Configurations	↑↑			↑↑	↘↘	↗
Traffic Volume (vph)	619	0	0	1772	168	534
Future Volume (vph)	619	0	0	1772	168	534
Ideal Flow (vphpl)	1900	1900	1900	1900	1900	1900
Total Lost time (s)	6.5			6.5	4.5	4.0
Lane Util. Factor	0.95			0.95	0.97	1.00
Frt	1.00			1.00	1.00	0.85
Flt Protected	1.00			1.00	0.95	1.00
Satd. Flow (prot)	3539			3539	3433	1583
Flt Permitted	1.00			1.00	0.95	1.00
Satd. Flow (perm)	3539			3539	3433	1583
Peak-hour factor, PHF	0.92	0.92	0.92	0.92	0.92	0.92
Adj. Flow (vph)	673	0	0	1926	183	580
RTOR Reduction (vph)	0	0	0	0	0	0
Lane Group Flow (vph)	673	0	0	1926	183	580
Turn Type	NA			NA	Prot	Free
Protected Phases	6 7			6 7	5 8	
Permitted Phases						Free
Actuated Green, G (s)	96.0			96.0	35.0	140.0
Effective Green, g (s)	96.0			96.0	35.0	140.0
Actuated g/C Ratio	0.69			0.69	0.25	1.00
Clearance Time (s)						
Vehicle Extension (s)						
Lane Grp Cap (vph)	2426			2426	858	1583
v/s Ratio Prot	0.19			c0.54	0.05	
v/s Ratio Perm						c0.37
v/c Ratio	0.28			0.79	0.21	0.37
Uniform Delay, d1	8.5			15.2	41.6	0.0
Progression Factor	0.69			1.00	1.00	1.00
Incremental Delay, d2	0.0			1.7	0.0	0.7
Delay (s)	5.9			16.9	41.6	0.7
Level of Service	A			B	D	A
Approach Delay (s)	5.9			16.9	10.5	
Approach LOS	A			B	B	





















### Intersection Summary

HCM 2000 Control Delay	13.3	HCM 2000 Level of Service	B
HCM 2000 Volume to Capacity ratio	0.77		
Actuated Cycle Length (s)	140.0	Sum of lost time (s)	22.0
Intersection Capacity Utilization	64.0%	ICU Level of Service	B
Analysis Period (min)	15		

c Critical Lane Group























HCM 2010 Signalized Intersection Summary  
 1: Cowan Street & Jefferson Street/Spring Street

River North  
 Existing PM

												
Movement	EBL	EBT	EBR	WBL	WBT	WBR	NBL	NBT	NBR	SBL	SBT	SBR
Lane Configurations												
Traffic Volume (veh/h)	222	1773	150	18	805	108	53	59	53	133	34	101
Future Volume (veh/h)	222	1773	150	18	805	108	53	59	53	133	34	101
Number	1	6	16	5	2	12	7	4	14	3	8	18
Initial Q (Qb), veh	0	0	0	0	0	0	0	0	0	0	0	0
Ped-Bike Adj(A_pbT)	1.00		1.00	1.00		1.00	1.00		1.00	1.00		1.00
Parking Bus, Adj	1.00	1.00	1.00	1.00	1.00	1.00	1.00	1.00	1.00	1.00	1.00	1.00
Adj Sat Flow, veh/h/ln	1863	1863	1863	1863	1863	1900	1863	1863	1900	1863	1863	1900
Adj Flow Rate, veh/h	241	1927	163	20	875	117	58	64	58	145	37	110
Adj No. of Lanes	1	2	1	1	3	0	1	1	0	1	1	0
Peak Hour Factor	0.92	0.92	0.92	0.92	0.92	0.92	0.92	0.92	0.92	0.92	0.92	0.92
Percent Heavy Veh, %	2	2	2	2	2	2	2	2	2	2	2	2
Cap, veh/h	506	2279	1019	122	2687	358	189	172	156	214	79	235
Arrive On Green	0.07	0.64	0.64	0.03	1.00	1.00	0.19	0.19	0.19	0.19	0.19	0.19
Sat Flow, veh/h	1774	3539	1583	1774	4542	605	1236	902	817	1264	414	1231
Grp Volume(v), veh/h	241	1927	163	20	652	340	58	0	122	145	0	147
Grp Sat Flow(s),veh/h/ln	1774	1770	1583	1774	1695	1756	1236	0	1719	1264	0	1645
Q Serve(g_s), s	7.2	59.6	5.7	0.6	0.0	0.0	6.1	0.0	8.7	15.8	0.0	11.1
Cycle Q Clear(g_c), s	7.2	59.6	5.7	0.6	0.0	0.0	17.2	0.0	8.7	24.5	0.0	11.1
Prop In Lane	1.00		1.00	1.00		0.34	1.00		0.48	1.00		0.75
Lane Grp Cap(c), veh/h	506	2279	1019	122	2006	1039	189	0	328	214	0	314
V/C Ratio(X)	0.48	0.85	0.16	0.16	0.33	0.33	0.31	0.00	0.37	0.68	0.00	0.47
Avail Cap(c_a), veh/h	589	2279	1019	196	2006	1039	200	0	344	226	0	329
HCM Platoon Ratio	1.00	1.00	1.00	2.00	2.00	2.00	1.00	1.00	1.00	1.00	1.00	1.00
Upstream Filter(I)	1.00	1.00	1.00	0.83	0.83	0.83	1.00	0.00	1.00	1.00	0.00	1.00
Uniform Delay (d), s/veh	8.7	19.5	9.9	21.4	0.0	0.0	58.0	0.0	49.3	60.0	0.0	50.3
Incr Delay (d2), s/veh	0.3	4.1	0.3	0.2	0.4	0.7	0.3	0.0	0.3	5.7	0.0	0.4
Initial Q Delay(d3),s/veh	0.0	0.0	0.0	0.0	0.0	0.0	0.0	0.0	0.0	0.0	0.0	0.0
%ile BackOfQ(50%),veh/ln	3.5	30.2	2.6	0.3	0.1	0.2	2.1	0.0	4.1	5.9	0.0	5.1
LnGrp Delay(d),s/veh	8.9	23.6	10.2	21.6	0.4	0.7	58.3	0.0	49.6	65.7	0.0	50.7
LnGrp LOS	A	C	B	C	A	A	E		D	E		D
Approach Vol, veh/h		2331			1012			180			292	
Approach Delay, s/veh		21.1			0.9			52.4			58.2	
Approach LOS		C			A			D			E	
Timer	1	2	3	4	5	6	7	8				
Assigned Phs	1	2		4	5	6		8				
Phs Duration (G+Y+Rc), s	16.5	89.8		33.7	9.2	97.1		33.7				
Change Period (Y+Rc), s	7.0	7.0		7.0	7.0	7.0		7.0				
Max Green Setting (Gmax), s	16.0	75.0		28.0	8.0	83.0		28.0				
Max Q Clear Time (g_c+I1), s	9.2	2.0		19.2	2.6	61.6		26.5				
Green Ext Time (p_c), s	0.3	16.2		0.9	0.0	11.4		0.2				
<b>Intersection Summary</b>												
HCM 2010 Ctrl Delay				20.1								
HCM 2010 LOS				C								
<b>Notes</b>												

HCM 2010 Signalized Intersection Summary  
2: N 1st Street & Spring Street

River North  
Existing PM

												
Movement	EBL	EBT	EBR	WBL	WBT	WBR	NBL	NBT	NBR	SBL	SBT	SBR
Lane Configurations												
Traffic Volume (veh/h)	579	1347	34	66	620	86	113	406	195	99	175	184
Future Volume (veh/h)	579	1347	34	66	620	86	113	406	195	99	175	184
Number	1	6	16	5	2	12	7	4	14	3	8	18
Initial Q (Qb), veh	0	0	0	0	0	0	0	0	0	0	0	0
Ped-Bike Adj(A_pbT)	1.00		1.00	1.00		1.00	1.00		1.00	1.00		1.00
Parking Bus, Adj	1.00	1.00	1.00	1.00	1.00	1.00	1.00	1.00	1.00	1.00	1.00	1.00
Adj Sat Flow, veh/h/ln	1863	1863	1900	1863	1863	1900	1863	1863	1863	1863	1863	1863
Adj Flow Rate, veh/h	629	1464	37	72	674	93	123	441	212	108	165	217
Adj No. of Lanes	2	2	0	1	2	0	1	2	1	1	1	2
Peak Hour Factor	0.92	0.92	0.92	0.92	0.92	0.92	0.92	0.92	0.92	0.92	0.92	0.92
Percent Heavy Veh, %	2	2	2	2	2	2	2	2	2	2	2	2
Cap, veh/h	824	2066	52	251	1261	174	173	379	170	159	200	339
Arrive On Green	0.48	1.00	1.00	0.05	0.40	0.40	0.06	0.11	0.11	0.06	0.11	0.11
Sat Flow, veh/h	3442	3528	89	1774	3126	431	1774	3539	1583	1774	1863	3167
Grp Volume(v), veh/h	629	734	767	72	381	386	123	441	212	108	165	217
Grp Sat Flow(s),veh/h/ln	1721	1770	1847	1774	1770	1787	1774	1770	1583	1774	1863	1583
Q Serve(g_s), s	21.0	0.0	0.0	3.7	22.9	23.0	8.0	15.0	15.0	7.6	12.1	5.7
Cycle Q Clear(g_c), s	21.0	0.0	0.0	3.7	22.9	23.0	8.0	15.0	15.0	7.6	12.1	5.7
Prop In Lane	1.00		0.05	1.00		0.24	1.00		1.00	1.00		1.00
Lane Grp Cap(c), veh/h	824	1036	1082	251	714	721	173	379	170	159	200	339
V/C Ratio(X)	0.76	0.71	0.71	0.29	0.53	0.53	0.71	1.16	1.25	0.68	0.83	0.64
Avail Cap(c_a), veh/h	824	1036	1082	257	714	721	173	379	170	159	200	339
HCM Platoon Ratio	2.00	2.00	2.00	1.00	1.00	1.00	1.00	1.00	1.00	1.00	1.00	1.00
Upstream Filter(I)	0.53	0.53	0.53	1.00	1.00	1.00	1.00	1.00	1.00	1.00	1.00	1.00
Uniform Delay (d), s/veh	33.2	0.0	0.0	29.2	31.7	31.8	54.1	62.5	62.5	52.4	61.2	23.3
Incr Delay (d2), s/veh	2.4	2.2	2.1	0.2	2.8	2.8	11.0	98.5	151.7	9.2	22.7	3.1
Initial Q Delay(d3),s/veh	0.0	0.0	0.0	0.0	0.0	0.0	0.0	0.0	0.0	0.0	0.0	0.0
%ile BackOfQ(50%),veh/ln	10.1	0.6	0.6	1.8	11.8	11.9	1.4	12.5	13.7	4.1	7.5	2.6
LnGrp Delay(d),s/veh	35.6	2.2	2.1	29.4	34.6	34.6	65.1	161.0	214.2	61.6	83.9	26.4
LnGrp LOS	D	A	A	C	C	C	E	F	F	E	F	C
Approach Vol, veh/h		2130			839			776			490	
Approach Delay, s/veh		12.0			34.1			160.4			53.5	
Approach LOS		B			C			F			D	
Timer	1	2	3	4	5	6	7	8				
Assigned Phs	1	2	3	4	5	6	7	8				
Phs Duration (G+Y+Rc), s	40.0	63.0	15.0	22.0	14.5	88.5	15.0	22.0				
Change Period (Y+Rc), s	6.5	6.5	6.5	7.0	7.0	6.5	7.0	7.0				
Max Green Setting (Gmax), s	33.5	56.5	8.5	15.0	8.0	81.5	8.0	15.0				
Max Q Clear Time (g_c+I1), s	23.0	25.0	9.6	17.0	5.7	2.0	10.0	14.1				
Green Ext Time (p_c), s	5.7	1.6	0.0	0.0	0.0	9.7	0.0	0.4				
<b>Intersection Summary</b>												
HCM 2010 Ctrl Delay			48.4									
HCM 2010 LOS			D									
<b>Notes</b>												

# HCM Signalized Intersection Capacity Analysis

## 3: Spring Street & Dickerson Pike

River North  
Existing PM



Movement	EBL	EBT	EBR	WBL	WBT	WBR	SBL2	SBL	SBR	NWL	NWR
Lane Configurations											
Traffic Volume (vph)	178	1092	189	0	845	558	90	0	126	0	0
Future Volume (vph)	178	1092	189	0	845	558	90	0	126	0	0
Ideal Flow (vphpl)	1900	1900	1900	1900	1900	1900	1900	1900	1900	1900	1900
Total Lost time (s)	6.5	6.5	6.5		6.5	6.5	4.5		4.5		
Lane Util. Factor	1.00	0.95	1.00		0.91	0.91	1.00		1.00		
Frt	1.00	1.00	0.85		0.98	0.85	1.00		0.85		
Flt Protected	0.95	1.00	1.00		1.00	1.00	0.95		1.00		
Satd. Flow (prot)	1770	3539	1583		3320	1441	1770		1583		
Flt Permitted	0.23	1.00	1.00		1.00	1.00	0.95		1.00		
Satd. Flow (perm)	421	3539	1583		3320	1441	1770		1583		
Peak-hour factor, PHF	0.92	0.92	0.92	0.92	0.92	0.92	0.92	0.92	0.92	0.92	0.92
Adj. Flow (vph)	193	1187	205	0	918	607	98	0	137	0	0
RTOR Reduction (vph)	0	0	57	0	7	127	0	0	122	0	0
Lane Group Flow (vph)	193	1187	148	0	1057	334	98	0	15	0	0
Turn Type	D.P+P	NA	custom		NA	Perm	Prot		Prot		
Protected Phases	1	2			2 3		4		4		
Permitted Phases	2 3	2 3	2 3			2 3					
Actuated Green, G (s)	109.0	94.8	101.3		101.3	101.3	15.5		15.5		
Effective Green, g (s)	109.0	94.8	101.3		101.3	101.3	15.5		15.5		
Actuated g/C Ratio	0.78	0.68	0.72		0.72	0.72	0.11		0.11		
Clearance Time (s)	6.5	6.5					4.5		4.5		
Vehicle Extension (s)	2.0	2.0					2.0		2.0		
Lane Grp Cap (vph)	401	2560	1145		2402	1042	195		175		
v/s Ratio Prot	c0.03	0.30			0.32		c0.06		0.01		
v/s Ratio Perm	c0.35	0.04	0.09			0.23					
v/c Ratio	0.48	0.46	0.13		0.44	0.32	0.50		0.09		
Uniform Delay, d1	4.7	10.6	5.9		7.8	7.0	58.6		55.9		
Progression Factor	0.82	0.81	0.43		1.11	3.36	1.00		1.00		
Incremental Delay, d2	0.3	0.0	0.0		0.0	0.1	0.7		0.1		
Delay (s)	4.2	8.6	2.5		8.7	23.5	59.4		56.0		
Level of Service	A	A	A		A	C	E		E		
Approach Delay (s)		7.3			13.2			57.4		0.0	
Approach LOS		A			B			E		A	

### Intersection Summary

HCM 2000 Control Delay	13.5	HCM 2000 Level of Service	B
HCM 2000 Volume to Capacity ratio	0.51		
Actuated Cycle Length (s)	140.0	Sum of lost time (s)	22.0
Intersection Capacity Utilization	58.3%	ICU Level of Service	B
Analysis Period (min)	15		

c Critical Lane Group

# HCM Signalized Intersection Capacity Analysis

## 4: I-24 WB Off-Ramp & Spring Street

River North  
Existing PM



Movement	EBT	EBR	WBL	WBT	NBL	NBR
Lane Configurations	↑↑			↑↑	↘↘	↗
Traffic Volume (vph)	1152	0	0	1089	349	885
Future Volume (vph)	1152	0	0	1089	349	885
Ideal Flow (vphpl)	1900	1900	1900	1900	1900	1900
Total Lost time (s)	6.5			6.5	4.5	4.0
Lane Util. Factor	0.95			0.95	0.97	1.00
Frt	1.00			1.00	1.00	0.85
Flt Protected	1.00			1.00	0.95	1.00
Satd. Flow (prot)	3539			3539	3433	1583
Flt Permitted	1.00			1.00	0.95	1.00
Satd. Flow (perm)	3539			3539	3433	1583
Peak-hour factor, PHF	0.92	0.92	0.92	0.92	0.92	0.92
Adj. Flow (vph)	1252	0	0	1184	379	962
RTOR Reduction (vph)	0	0	0	0	0	0
Lane Group Flow (vph)	1252	0	0	1184	379	962
Turn Type	NA			NA	Prot	Free
Protected Phases	6 7			6 7	5 8	
Permitted Phases						Free
Actuated Green, G (s)	103.5			103.5	27.5	140.0
Effective Green, g (s)	103.5			103.5	27.5	140.0
Actuated g/C Ratio	0.74			0.74	0.20	1.00
Clearance Time (s)						
Vehicle Extension (s)						
Lane Grp Cap (vph)	2616			2616	674	1583
v/s Ratio Prot	0.35			0.33	0.11	
v/s Ratio Perm						c0.61
v/c Ratio	0.48			0.45	0.56	0.61
Uniform Delay, d1	7.4			7.2	50.8	0.0
Progression Factor	0.39			1.00	1.00	1.00
Incremental Delay, d2	0.0			0.0	0.6	1.7
Delay (s)	2.9			7.2	51.5	1.7
Level of Service	A			A	D	A
Approach Delay (s)	2.9			7.2	15.8	
Approach LOS	A			A	B	

### Intersection Summary

























HCM 2000 Control Delay	8.8	HCM 2000 Level of Service	A
HCM 2000 Volume to Capacity ratio	0.72		
Actuated Cycle Length (s)	140.0	Sum of lost time (s)	22.0
Intersection Capacity Utilization	51.0%	ICU Level of Service	A
Analysis Period (min)	15		

c Critical Lane Group

PROJECTED CONDITIONS  
CAPACITY ANALYSES

HCM 2010 Signalized Intersection Summary  
 1: Cowan Street & Jefferson Street/Spring Street

























River North-Low-Level  
 Projected PM

												
Movement	EBL	EBT	EBR	WBL	WBT	WBR	NBL	NBT	NBR	SBL	SBT	SBR
Lane Configurations												
Traffic Volume (veh/h)	267	1773	150	18	805	376	53	77	53	597	65	179
Future Volume (veh/h)	267	1773	150	18	805	376	53	77	53	597	65	179
Number	1	6	16	5	2	12	7	4	14	3	8	18
Initial Q (Qb), veh	0	0	0	0	0	0	0	0	0	0	0	0
Ped-Bike Adj(A_pbT)	1.00		1.00	1.00		1.00	1.00		1.00	1.00		1.00
Parking Bus, Adj	1.00	1.00	1.00	1.00	1.00	1.00	1.00	1.00	1.00	1.00	1.00	1.00
Adj Sat Flow, veh/h/ln	1863	1863	1863	1863	1863	1863	1863	1863	1900	1863	1863	1863
Adj Flow Rate, veh/h	290	1927	163	20	875	0	58	84	58	649	71	195
Adj No. of Lanes	1	2	1	1	3	1	1	1	0	2	1	1
Peak Hour Factor	0.92	0.92	0.92	0.92	0.92	0.92	0.92	0.92	0.92	0.92	0.92	0.92
Percent Heavy Veh, %	2	2	2	2	2	2	2	2	2	2	2	2
Cap, veh/h	478	1821	815	75	2157	672	159	102	71	691	615	523
Arrive On Green	0.11	0.51	0.51	0.03	0.85	0.00	0.10	0.10	0.10	0.20	0.33	0.33
Sat Flow, veh/h	1774	3539	1583	1774	5085	1583	1109	1028	710	3442	1863	1583
Grp Volume(v), veh/h	290	1927	163	20	875	0	58	0	142	649	71	195
Grp Sat Flow(s),veh/h/ln	1774	1770	1583	1774	1695	1583	1109	0	1738	1721	1863	1583
Q Serve(g_s), s	13.4	77.2	8.4	1.0	6.0	0.0	7.5	0.0	12.0	27.9	4.0	14.1
Cycle Q Clear(g_c), s	13.4	77.2	8.4	1.0	6.0	0.0	7.5	0.0	12.0	27.9	4.0	14.1
Prop In Lane	1.00		1.00	1.00		1.00	1.00		0.41	1.00		1.00
Lane Grp Cap(c), veh/h	478	1821	815	75	2157	672	159	0	173	691	615	523
V/C Ratio(X)	0.61	1.06	0.20	0.27	0.41	0.00	0.37	0.00	0.82	0.94	0.12	0.37
Avail Cap(c_a), veh/h	574	1821	815	95	2157	672	285	0	371	700	832	707
HCM Platoon Ratio	1.00	1.00	1.00	2.00	2.00	2.00	1.00	1.00	1.00	1.00	1.00	1.00
Upstream Filter(I)	1.00	1.00	1.00	0.83	0.83	0.00	1.00	0.00	1.00	1.00	1.00	1.00
Uniform Delay (d), s/veh	19.1	36.4	19.7	36.8	7.0	0.0	64.1	0.0	66.2	59.1	35.0	38.3
Incr Delay (d2), s/veh	0.5	38.5	0.6	0.6	0.5	0.0	0.5	0.0	3.6	20.5	0.0	0.2
Initial Q Delay(d3),s/veh	0.0	0.0	0.0	0.0	0.0	0.0	0.0	0.0	0.0	0.0	0.0	0.0
%ile BackOfQ(50%),veh/ln	6.6	47.4	3.8	0.5	2.7	0.0	2.3	0.0	6.0	15.2	2.1	6.2
LnGrp Delay(d),s/veh	19.6	74.9	20.3	37.4	7.5	0.0	64.7	0.0	69.8	79.5	35.0	38.5
LnGrp LOS	B	F	C	D	A		E		E	E	C	D
Approach Vol, veh/h		2380			895			200			915	
Approach Delay, s/veh		64.4			8.1			68.3			67.3	
Approach LOS		E			A			E			E	
Timer	1	2	3	4	5	6	7	8				
Assigned Phs	1	2	3	4	5	6		8				
Phs Duration (G+Y+Rc), s	22.8	70.6	34.6	22.0	9.3	84.2		56.6				
Change Period (Y+Rc), s	7.0	7.0	4.5	7.0	7.0	7.0		7.0				
Max Green Setting (Gmax), s	24.0	38.0	30.5	32.0	4.0	58.0		67.0				
Max Q Clear Time (g_c+I1), s	15.4	8.0	29.9	14.0	3.0	79.2		16.1				
Green Ext Time (p_c), s	0.4	13.1	0.2	0.9	0.0	0.0		1.0				
<b>Intersection Summary</b>												
HCM 2010 Ctrl Delay			53.7									
HCM 2010 LOS			D									
<b>Notes</b>												



























HCM 2010 Signalized Intersection Summary  
 1: Cowan Street & Jefferson Street/Spring Street

River North-Medium-Level  
 Projected PM

												
Movement	EBL	EBT	EBR	WBL	WBT	WBR	NBL	NBT	NBR	SBL	SBT	SBR
Lane Configurations												
Traffic Volume (veh/h)	365	1773	150	18	805	964	53	116	53	1291	112	295
Future Volume (veh/h)	365	1773	150	18	805	964	53	116	53	1291	112	295
Number	1	6	16	5	2	12	7	4	14	3	8	18
Initial Q (Qb), veh	0	0	0	0	0	0	0	0	0	0	0	0
Ped-Bike Adj(A_pbT)	1.00		1.00	1.00		1.00	1.00		1.00	1.00		1.00
Parking Bus, Adj	1.00	1.00	1.00	1.00	1.00	1.00	1.00	1.00	1.00	1.00	1.00	1.00
Adj Sat Flow, veh/h/ln	1863	1863	1863	1863	1863	1863	1863	1863	1900	1863	1863	1863
Adj Flow Rate, veh/h	397	1927	163	20	875	0	58	126	58	1403	271	222
Adj No. of Lanes	1	3	1	1	3	1	1	1	0	3	1	1
Peak Hour Factor	0.92	0.92	0.92	0.92	0.92	0.92	0.92	0.92	0.92	0.92	0.92	0.92
Percent Heavy Veh, %	2	2	2	2	2	2	2	2	2	2	2	2
Cap, veh/h	432	2192	682	86	1360	424	201	113	52	1473	648	551
Arrive On Green	0.18	0.43	0.43	0.01	0.27	0.00	0.04	0.09	0.09	0.28	0.35	0.35
Sat Flow, veh/h	1774	5085	1583	1774	5085	1583	1774	1208	556	5322	1863	1583
Grp Volume(v), veh/h	397	1927	163	20	875	0	58	0	184	1403	271	222
Grp Sat Flow(s),veh/h/ln	1774	1695	1583	1774	1695	1583	1774	0	1765	1774	1863	1583
Q Serve(g_s), s	23.5	52.1	9.8	1.2	22.8	0.0	4.4	0.0	14.0	38.8	16.7	16.0
Cycle Q Clear(g_c), s	23.5	52.1	9.8	1.2	22.8	0.0	4.4	0.0	14.0	38.8	16.7	16.0
Prop In Lane	1.00		1.00	1.00		1.00	1.00		0.32	1.00		1.00
Lane Grp Cap(c), veh/h	432	2192	682	86	1360	424	201	0	165	1473	648	551
V/C Ratio(X)	0.92	0.88	0.24	0.23	0.64	0.00	0.29	0.00	1.12	0.95	0.42	0.40
Avail Cap(c_a), veh/h	736	2192	682	100	1360	424	221	0	165	1490	648	551
HCM Platoon Ratio	1.00	1.00	1.00	1.00	1.00	1.00	1.00	1.00	1.00	1.00	1.00	1.00
Upstream Filter(I)	1.00	1.00	1.00	0.73	0.73	0.00	1.00	0.00	1.00	1.00	1.00	1.00
Uniform Delay (d), s/veh	32.9	39.1	27.1	42.2	48.6	0.0	58.4	0.0	68.0	53.3	37.3	37.1
Incr Delay (d2), s/veh	6.1	5.4	0.8	0.4	1.7	0.0	0.8	0.0	105.1	13.4	0.2	0.2
Initial Q Delay(d3),s/veh	0.0	0.0	0.0	0.0	0.0	0.0	0.0	0.0	0.0	0.0	0.0	0.0
%ile BackOfQ(50%),veh/ln	12.1	25.4	4.4	0.6	10.9	0.0	2.2	0.0	11.6	20.8	8.6	7.0
LnGrp Delay(d),s/veh	39.0	44.5	27.9	42.5	50.3	0.0	59.2	0.0	173.1	66.7	37.5	37.3
LnGrp LOS	D	D	C	D	D		E		F	E	D	D
Approach Vol, veh/h		2487			895			242			1896	
Approach Delay, s/veh		42.6			50.2			145.8			59.0	
Approach LOS		D			D			F			E	
Timer	1	2	3	4	5	6	7	8				
Assigned Phs	1	2	3	4	5	6	7	8				
Phs Duration (G+Y+Rc), s	33.4	47.1	48.5	21.0	8.8	71.6	10.3	59.2				
Change Period (Y+Rc), s	7.0	7.0	7.0	7.0	7.0	7.0	4.5	7.0				
Max Green Setting (Gmax), s	52.0	14.0	42.0	14.0	3.0	63.0	7.5	51.0				
Max Q Clear Time (g_c+I1), s	25.5	24.8	40.8	16.0	3.2	54.1	6.4	18.7				
Green Ext Time (p_c), s	0.8	0.0	0.7	0.0	0.0	6.2	0.0	1.4				
<b>Intersection Summary</b>												
HCM 2010 Ctrl Delay			54.0									
HCM 2010 LOS			D									
<b>Notes</b>												

























HCM 2010 Signalized Intersection Summary  
 1: Cowan Street & Jefferson Street/Spring Street

River North-High-Level-Option 1A  
 Projected PM

												
Movement	EBL	EBT	EBR	WBL	WBT	WBR	NBL	NBT	NBR	SBL	SBT	SBR
Lane Configurations												
Traffic Volume (veh/h)	294	1773	150	18	805	420	53	88	53	556	73	198
Future Volume (veh/h)	294	1773	150	18	805	420	53	88	53	556	73	198
Number	1	6	16	5	2	12	7	4	14	3	8	18
Initial Q (Qb), veh	0	0	0	0	0	0	0	0	0	0	0	0
Ped-Bike Adj(A_pbT)	1.00		1.00	1.00		1.00	1.00		1.00	1.00		1.00
Parking Bus, Adj	1.00	1.00	1.00	1.00	1.00	1.00	1.00	1.00	1.00	1.00	1.00	1.00
Adj Sat Flow, veh/h/ln	1863	1863	1863	1863	1863	1863	1863	1863	1900	1863	1863	1863
Adj Flow Rate, veh/h	320	1927	163	20	875	0	58	96	58	604	181	147
Adj No. of Lanes	1	3	1	1	3	1	1	1	0	2	1	1
Peak Hour Factor	0.92	0.92	0.92	0.92	0.92	0.92	0.92	0.92	0.92	0.92	0.92	0.92
Percent Heavy Veh, %	2	2	2	2	2	2	2	2	2	2	2	2
Cap, veh/h	415	2607	812	110	2060	641	217	114	69	656	508	432
Arrive On Green	0.12	0.51	0.51	0.00	0.13	0.00	0.03	0.10	0.10	0.18	0.27	0.27
Sat Flow, veh/h	1774	5085	1583	1774	5085	1583	1774	1089	658	3548	1863	1583
Grp Volume(v), veh/h	320	1927	163	20	875	0	58	0	154	604	181	147
Grp Sat Flow(s),veh/h/ln	1774	1695	1583	1774	1695	1583	1774	0	1747	1774	1863	1583
Q Serve(g_s), s	15.3	44.6	8.4	1.0	23.7	0.0	4.4	0.0	13.0	25.1	11.7	11.2
Cycle Q Clear(g_c), s	15.3	44.6	8.4	1.0	23.7	0.0	4.4	0.0	13.0	25.1	11.7	11.2
Prop In Lane	1.00		1.00	1.00		1.00	1.00		0.38	1.00		1.00
Lane Grp Cap(c), veh/h	415	2607	812	110	2060	641	217	0	183	656	508	432
V/C Ratio(X)	0.77	0.74	0.20	0.18	0.42	0.00	0.27	0.00	0.84	0.92	0.36	0.34
Avail Cap(c_a), veh/h	570	2607	812	126	2060	641	217	0	262	710	621	528
HCM Platoon Ratio	1.00	1.00	1.00	0.33	0.33	0.33	1.00	1.00	1.00	1.00	1.00	1.00
Upstream Filter(I)	1.00	1.00	1.00	0.73	0.73	0.00	1.00	0.00	1.00	1.00	1.00	1.00
Uniform Delay (d), s/veh	24.1	28.7	19.9	29.1	48.9	0.0	57.6	0.0	66.0	60.1	43.9	43.7
Incr Delay (d2), s/veh	2.7	1.9	0.6	0.2	0.5	0.0	0.7	0.0	11.1	16.0	0.2	0.2
Initial Q Delay(d3),s/veh	0.0	0.0	0.0	0.0	0.0	0.0	0.0	0.0	0.0	0.0	0.0	0.0
%ile BackOfQ(50%),veh/ln	7.8	21.3	3.8	0.5	11.2	0.0	2.2	0.0	6.9	13.8	6.1	4.9
LnGrp Delay(d),s/veh	26.8	30.6	20.4	29.3	49.4	0.0	58.3	0.0	77.0	76.1	44.1	43.9
LnGrp LOS	C	C	C	C	D		E		E	E	D	D
Approach Vol, veh/h		2410			895			212			932	
Approach Delay, s/veh		29.4			48.9			71.9			64.8	
Approach LOS		C			D			E			E	
Timer	1	2	3	4	5	6	7	8				
Assigned Phs	1	2	3	4	5	6	7	8				
Phs Duration (G+Y+Rc), s	24.8	67.8	34.7	22.7	8.7	83.9	9.5	47.9				
Change Period (Y+Rc), s	7.0	7.0	7.0	7.0	7.0	7.0	4.5	7.0				
Max Green Setting (Gmax), s	31.0	38.5	30.0	22.5	3.0	66.5	5.0	50.0				
Max Q Clear Time (g_c+I1), s	17.3	25.7	27.1	15.0	3.0	46.6	6.4	13.7				
Green Ext Time (p_c), s	0.6	8.1	0.6	0.7	0.0	10.5	0.0	1.0				
<b>Intersection Summary</b>												
HCM 2010 Ctrl Delay			42.8									
HCM 2010 LOS			D									
<b>Notes</b>												

























HCM 2010 Signalized Intersection Summary  
 1: Cowan Street & Jefferson Street/Spring Street

River North-High-Level-Option 1B  
 Projected PM

												
Movement	EBL	EBT	EBR	WBL	WBT	WBR	NBL	NBT	NBR	SBL	SBT	SBR
Lane Configurations												
Traffic Volume (veh/h)	394	1773	150	18	805	858	53	128	53	1149	127	334
Future Volume (veh/h)	394	1773	150	18	805	858	53	128	53	1149	127	334
Number	1	6	16	5	2	12	7	4	14	3	8	18
Initial Q (Qb), veh	0	0	0	0	0	0	0	0	0	0	0	0
Ped-Bike Adj(A_pbT)	1.00		1.00	1.00		1.00	1.00		1.00	1.00		1.00
Parking Bus, Adj	1.00	1.00	1.00	1.00	1.00	1.00	1.00	1.00	1.00	1.00	1.00	1.00
Adj Sat Flow, veh/h/ln	1863	1863	1863	1863	1863	1863	1863	1863	1900	1863	1863	1863
Adj Flow Rate, veh/h	428	1927	163	20	875	0	58	139	58	1249	307	250
Adj No. of Lanes	1	3	1	1	3	1	1	1	0	3	1	1
Peak Hour Factor	0.92	0.92	0.92	0.92	0.92	0.92	0.92	0.92	0.92	0.92	0.92	0.92
Percent Heavy Veh, %	2	2	2	2	2	2	2	2	2	2	2	2
Cap, veh/h	435	2121	660	85	1239	386	227	160	67	1293	653	555
Arrive On Green	0.19	0.42	0.42	0.01	0.24	0.00	0.04	0.13	0.13	0.24	0.35	0.35
Sat Flow, veh/h	1774	5085	1583	1774	5085	1583	1774	1249	521	5322	1863	1583
Grp Volume(v), veh/h	428	1927	163	20	875	0	58	0	197	1249	307	250
Grp Sat Flow(s),veh/h/ln	1774	1695	1583	1774	1695	1583	1774	0	1771	1774	1863	1583
Q Serve(g_s), s	25.2	49.8	9.4	1.2	22.0	0.0	3.9	0.0	15.3	32.5	17.9	17.1
Cycle Q Clear(g_c), s	25.2	49.8	9.4	1.2	22.0	0.0	3.9	0.0	15.3	32.5	17.9	17.1
Prop In Lane	1.00		1.00	1.00		1.00	1.00		0.29	1.00		1.00
Lane Grp Cap(c), veh/h	435	2121	660	85	1239	386	227	0	226	1293	653	555
V/C Ratio(X)	0.98	0.91	0.25	0.23	0.71	0.00	0.26	0.00	0.87	0.97	0.47	0.45
Avail Cap(c_a), veh/h	435	2121	660	101	1239	386	231	0	253	1293	677	576
HCM Platoon Ratio	1.00	1.00	1.00	1.00	1.00	1.00	1.00	1.00	1.00	1.00	1.00	1.00
Upstream Filter(I)	1.00	1.00	1.00	0.73	0.73	0.00	1.00	0.00	1.00	1.00	1.00	1.00
Uniform Delay (d), s/veh	33.5	38.3	26.5	41.8	48.4	0.0	50.4	0.0	59.9	52.4	35.4	35.1
Incr Delay (d2), s/veh	38.4	7.2	0.9	0.4	2.5	0.0	0.6	0.0	22.8	17.4	0.2	0.2
Initial Q Delay(d3),s/veh	0.0	0.0	0.0	0.0	0.0	0.0	0.0	0.0	0.0	0.0	0.0	0.0
%ile BackOfQ(50%),veh/ln	21.1	24.6	4.3	0.6	10.6	0.0	2.0	0.0	8.9	18.0	9.2	7.5
LnGrp Delay(d),s/veh	71.9	45.5	27.4	42.2	50.9	0.0	50.9	0.0	82.7	69.9	35.6	35.3
LnGrp LOS	E	D	C	D	D		D		F	E	D	D
Approach Vol, veh/h		2518			895			255			1806	
Approach Delay, s/veh		48.8			50.7			75.5			59.2	
Approach LOS		D			D			E			E	
Timer	1	2	3	4	5	6	7	8				
Assigned Phs	1	2	3	4	5	6	7	8				
Phs Duration (G+Y+Rc), s	33.0	41.1	41.0	24.9	8.7	65.4	9.8	56.1				
Change Period (Y+Rc), s	7.0	7.0	7.0	7.0	7.0	7.0	4.5	7.0				
Max Green Setting (Gmax), s	26.0	32.0	34.0	20.0	3.0	55.0	5.6	50.9				
Max Q Clear Time (g_c+I1), s	27.2	24.0	34.5	17.3	3.2	51.8	5.9	19.9				
Green Ext Time (p_c), s	0.0	5.7	0.0	0.6	0.0	2.6	0.0	1.6				
<b>Intersection Summary</b>												
HCM 2010 Ctrl Delay			53.8									
HCM 2010 LOS			D									
<b>Notes</b>												

























HCM 2010 Signalized Intersection Summary  
 1: Cowan Street & Jefferson Street/Spring Street

River North-High-Level-Option 1C  
 Projected PM

												
Movement	EBL	EBT	EBR	WBL	WBT	WBR	NBL	NBT	NBR	SBL	SBT	SBR
Lane Configurations												
Traffic Volume (veh/h)	287	1773	150	18	805	389	53	85	53	514	69	188
Future Volume (veh/h)	287	1773	150	18	805	389	53	85	53	514	69	188
Number	1	6	16	5	2	12	7	4	14	3	8	18
Initial Q (Qb), veh	0	0	0	0	0	0	0	0	0	0	0	0
Ped-Bike Adj(A_pbT)	1.00		1.00	1.00		1.00	1.00		1.00	1.00		1.00
Parking Bus, Adj	1.00	1.00	1.00	1.00	1.00	1.00	1.00	1.00	1.00	1.00	1.00	1.00
Adj Sat Flow, veh/h/ln	1863	1863	1863	1863	1863	1863	1863	1863	1900	1863	1863	1863
Adj Flow Rate, veh/h	312	1927	163	20	875	0	58	92	58	559	172	140
Adj No. of Lanes	1	2	1	1	3	1	1	1	0	2	1	1
Peak Hour Factor	0.92	0.92	0.92	0.92	0.92	0.92	0.92	0.92	0.92	0.92	0.92	0.92
Percent Heavy Veh, %	2	2	2	2	2	2	2	2	2	2	2	2
Cap, veh/h	442	1867	835	68	2164	674	216	110	69	610	481	408
Arrive On Green	0.11	0.53	0.53	0.01	0.43	0.00	0.03	0.10	0.10	0.17	0.26	0.26
Sat Flow, veh/h	1774	3539	1583	1774	5085	1583	1774	1070	674	3548	1863	1583
Grp Volume(v), veh/h	312	1927	163	20	875	0	58	0	150	559	172	140
Grp Sat Flow(s),veh/h/ln	1774	1770	1583	1774	1695	1583	1774	0	1744	1774	1863	1583
Q Serve(g_s), s	14.3	79.1	8.1	1.0	17.9	0.0	4.4	0.0	12.7	23.2	11.3	10.8
Cycle Q Clear(g_c), s	14.3	79.1	8.1	1.0	17.9	0.0	4.4	0.0	12.7	23.2	11.3	10.8
Prop In Lane	1.00		1.00	1.00		1.00	1.00		0.39	1.00		1.00
Lane Grp Cap(c), veh/h	442	1867	835	68	2164	674	216	0	179	610	481	408
V/C Ratio(X)	0.71	1.03	0.20	0.29	0.40	0.00	0.27	0.00	0.84	0.92	0.36	0.34
Avail Cap(c_a), veh/h	714	1867	835	83	2164	674	216	0	285	662	621	528
HCM Platoon Ratio	1.00	1.00	1.00	1.00	1.00	1.00	1.00	1.00	1.00	1.00	1.00	1.00
Upstream Filter(I)	1.00	1.00	1.00	0.73	0.73	0.00	1.00	0.00	1.00	1.00	1.00	1.00
Uniform Delay (d), s/veh	20.9	35.4	18.7	37.6	29.9	0.0	57.9	0.0	66.1	61.1	45.5	45.3
Incr Delay (d2), s/veh	0.8	29.7	0.5	0.6	0.4	0.0	0.7	0.0	6.2	16.2	0.2	0.2
Initial Q Delay(d3),s/veh	0.0	0.0	0.0	0.0	0.0	0.0	0.0	0.0	0.0	0.0	0.0	0.0
%ile BackOfQ(50%),veh/ln	7.1	46.1	3.7	0.5	8.4	0.0	2.2	0.0	6.4	12.8	5.9	4.7
LnGrp Delay(d),s/veh	21.7	65.1	19.2	38.3	30.3	0.0	58.5	0.0	72.2	77.2	45.7	45.5
LnGrp LOS	C	F	B	D	C		E		E	E	D	D
Approach Vol, veh/h		2402			895			208			871	
Approach Delay, s/veh		56.4			30.5			68.4			65.9	
Approach LOS		E			C			E			E	
Timer	1	2	3	4	5	6	7	8				
Assigned Phs	1	2	3	4	5	6	7	8				
Phs Duration (G+Y+Rc), s	24.0	70.8	32.8	22.4	8.7	86.1	9.5	45.7				
Change Period (Y+Rc), s	7.0	7.0	7.0	7.0	7.0	7.0	4.5	7.0				
Max Green Setting (Gmax), s	40.0	29.5	28.0	24.5	3.0	66.5	5.0	50.0				
Max Q Clear Time (g_c+I1), s	16.3	19.9	25.2	14.7	3.0	81.1	6.4	13.3				
Green Ext Time (p_c), s	0.6	6.7	0.6	0.7	0.0	0.0	0.0	0.9				
<b>Intersection Summary</b>												
HCM 2010 Ctrl Delay			53.5									
HCM 2010 LOS			D									
<b>Notes</b>												

HCM 2010 Signalized Intersection Summary  
 1: Cowan Street & Jefferson Street/Spring Street

River North-High-Level-Option 2A  
 Projected PM

												
Movement	EBL	EBT	EBR	WBL	WBT	WBR	NBL	NBT	NBR	SBL	SBT	SBR
Lane Configurations												
Traffic Volume (veh/h)	254	1596	150	18	724	757	53	97	53	1012	85	144
Future Volume (veh/h)	254	1596	150	18	724	757	53	97	53	1012	85	144
Number	1	6	16	5	2	12	7	4	14	3	8	18
Initial Q (Qb), veh	0	0	0	0	0	0	0	0	0	0	0	0
Ped-Bike Adj(A_pbT)	1.00		1.00	1.00		1.00	1.00		1.00	1.00		1.00
Parking Bus, Adj	1.00	1.00	1.00	1.00	1.00	1.00	1.00	1.00	1.00	1.00	1.00	1.00
Adj Sat Flow, veh/h/ln	1863	1863	1863	1863	1863	1863	1863	1863	1900	1863	1863	1863
Adj Flow Rate, veh/h	276	1735	163	20	787	0	58	105	58	1100	141	124
Adj No. of Lanes	1	3	1	1	3	1	1	1	0	2	1	1
Peak Hour Factor	0.92	0.92	0.92	0.92	0.92	0.92	0.92	0.92	0.92	0.92	0.92	0.92
Percent Heavy Veh, %	2	2	2	2	2	2	2	2	2	2	2	2
Cap, veh/h	354	1890	588	84	1334	415	241	123	68	1090	737	626
Arrive On Green	0.12	0.37	0.37	0.01	0.26	0.00	0.04	0.11	0.11	0.31	0.40	0.40
Sat Flow, veh/h	1774	5085	1583	1774	5085	1583	1774	1129	624	3548	1863	1583
Grp Volume(v), veh/h	276	1735	163	20	787	0	58	0	163	1100	141	124
Grp Sat Flow(s),veh/h/ln	1774	1695	1583	1774	1695	1583	1774	0	1753	1774	1863	1583
Q Serve(g_s), s	15.5	45.6	10.1	1.2	18.9	0.0	4.0	0.0	12.8	43.0	6.9	7.2
Cycle Q Clear(g_c), s	15.5	45.6	10.1	1.2	18.9	0.0	4.0	0.0	12.8	43.0	6.9	7.2
Prop In Lane	1.00		1.00	1.00		1.00	1.00		0.36	1.00		1.00
Lane Grp Cap(c), veh/h	354	1890	588	84	1334	415	241	0	191	1090	737	626
V/C Ratio(X)	0.78	0.92	0.28	0.24	0.59	0.00	0.24	0.00	0.85	1.01	0.19	0.20
Avail Cap(c_a), veh/h	354	1890	588	100	1334	415	242	0	250	1090	798	679
HCM Platoon Ratio	1.00	1.00	1.00	1.00	1.00	1.00	1.00	1.00	1.00	1.00	1.00	1.00
Upstream Filter(I)	1.00	1.00	1.00	0.73	0.73	0.00	1.00	0.00	1.00	1.00	1.00	1.00
Uniform Delay (d), s/veh	32.7	42.0	30.8	40.8	45.1	0.0	52.6	0.0	61.3	48.5	27.7	27.8
Incr Delay (d2), s/veh	9.7	8.7	1.2	0.4	1.4	0.0	0.5	0.0	15.7	29.6	0.0	0.1
Initial Q Delay(d3),s/veh	0.0	0.0	0.0	0.0	0.0	0.0	0.0	0.0	0.0	0.0	0.0	0.0
%ile BackOfQ(50%),veh/ln	8.5	22.9	4.6	0.6	9.1	0.0	2.0	0.0	7.0	25.5	3.6	3.2
LnGrp Delay(d),s/veh	42.4	50.6	32.0	41.2	46.5	0.0	53.1	0.0	77.0	78.1	27.7	27.8
LnGrp LOS	D	D	C	D	D		D		E	F	C	C
Approach Vol, veh/h		2174			807			221			1365	
Approach Delay, s/veh		48.2			46.3			70.7			68.3	
Approach LOS		D			D			E			E	
Timer	1	2	3	4	5	6	7	8				
Assigned Phs	1	2	3	4	5	6	7	8				
Phs Duration (G+Y+Rc), s	24.0	43.7	50.0	22.3	8.7	59.0	9.9	62.4				
Change Period (Y+Rc), s	7.0	7.0	7.0	7.0	7.0	7.0	4.5	7.0				
Max Green Setting (Gmax), s	17.0	32.0	43.0	20.0	3.0	46.0	5.5	60.0				
Max Q Clear Time (g_c+I1), s	17.5	20.9	45.0	14.8	3.2	47.6	6.0	9.2				
Green Ext Time (p_c), s	0.0	6.6	0.0	0.5	0.0	0.0	0.0	0.9				
<b>Intersection Summary</b>												
HCM 2010 Ctrl Delay			55.0									
HCM 2010 LOS			D									
<b>Notes</b>												

























HCM 2010 Signalized Intersection Summary  
 1: Cowan Street & Jefferson Street/Spring Street

River North-High-Level-Option 2B  
 Projected PM

Movement	EBL	EBT	EBR	WBL	WBT	WBR	NBL	NBT	NBR	SBL	SBT	SBR
Lane Configurations												
Traffic Volume (veh/h)	271	1596	150	18	724	1111	53	117	53	1494	113	167
Future Volume (veh/h)	271	1596	150	18	724	1111	53	117	53	1494	113	167
Number	1	6	16	5	2	12	7	4	14	3	8	18
Initial Q (Qb), veh	0	0	0	0	0	0	0	0	0	0	0	0
Ped-Bike Adj(A_pbT)	1.00		1.00	1.00		1.00	1.00		1.00	1.00		1.00
Parking Bus, Adj	1.00	1.00	1.00	1.00	1.00	1.00	1.00	1.00	1.00	1.00	1.00	1.00
Adj Sat Flow, veh/h/ln	1863	1863	1863	1863	1863	1863	1863	1863	1900	1863	1863	1863
Adj Flow Rate, veh/h	295	1735	163	20	787	0	58	127	58	1624	167	152
Adj No. of Lanes	1	3	1	1	3	1	1	1	0	3	1	1
Peak Hour Factor	0.92	0.92	0.92	0.92	0.92	0.92	0.92	0.92	0.92	0.92	0.92	0.92
Percent Heavy Veh, %	2	2	2	2	2	2	2	2	2	2	2	2
Cap, veh/h	364	1843	574	81	1196	372	219	113	51	1769	753	640
Arrive On Green	0.14	0.36	0.36	0.01	0.24	0.00	0.04	0.09	0.09	0.33	0.40	0.40
Sat Flow, veh/h	1774	5085	1583	1774	5085	1583	1774	1212	553	5322	1863	1583
Grp Volume(v), veh/h	295	1735	163	20	787	0	58	0	185	1624	167	152
Grp Sat Flow(s),veh/h/ln	1774	1695	1583	1774	1695	1583	1774	0	1765	1774	1863	1583
Q Serve(g_s), s	17.1	46.2	10.2	1.2	19.6	0.0	4.1	0.0	13.0	41.0	8.2	8.9
Cycle Q Clear(g_c), s	17.1	46.2	10.2	1.2	19.6	0.0	4.1	0.0	13.0	41.0	8.2	8.9
Prop In Lane	1.00		1.00	1.00		1.00	1.00		0.31	1.00		1.00
Lane Grp Cap(c), veh/h	364	1843	574	81	1196	372	219	0	164	1769	753	640
V/C Ratio(X)	0.81	0.94	0.28	0.25	0.66	0.00	0.27	0.00	1.13	0.92	0.22	0.24
Avail Cap(c_a), veh/h	497	1843	574	97	1196	372	219	0	164	1901	798	679
HCM Platoon Ratio	1.00	1.00	1.00	1.00	1.00	1.00	1.00	1.00	1.00	1.00	1.00	1.00
Upstream Filter(I)	1.00	1.00	1.00	0.73	0.73	0.00	1.00	0.00	1.00	1.00	1.00	1.00
Uniform Delay (d), s/veh	34.2	43.2	31.7	43.2	48.4	0.0	54.5	0.0	63.5	44.9	27.3	27.5
Incr Delay (d2), s/veh	5.0	11.1	1.2	0.4	2.1	0.0	0.6	0.0	109.1	7.0	0.1	0.1
Initial Q Delay(d3),s/veh	0.0	0.0	0.0	0.0	0.0	0.0	0.0	0.0	0.0	0.0	0.0	0.0
%ile BackOfQ(50%),veh/ln	8.8	23.6	4.7	0.6	9.4	0.0	2.0	0.0	11.3	21.3	4.2	3.9
LnGrp Delay(d),s/veh	39.3	54.3	33.0	43.7	50.5	0.0	55.2	0.0	172.6	51.9	27.4	27.6
LnGrp LOS	D	D	C	D	D		E		F	D	C	C
Approach Vol, veh/h		2193			807			243			1943	
Approach Delay, s/veh		50.7			50.4			144.5			47.9	
Approach LOS		D			D			F			D	
Timer	1	2	3	4	5	6	7	8				
Assigned Phs	1	2	3	4	5	6	7	8				
Phs Duration (G+Y+Rc), s	26.5	39.9	53.5	20.0	8.7	57.7	10.0	63.6				
Change Period (Y+Rc), s	7.0	7.0	7.0	7.0	7.0	7.0	4.5	7.0				
Max Green Setting (Gmax), s	30.0	19.0	50.0	13.0	3.0	46.0	5.5	60.0				
Max Q Clear Time (g_c+I1), s	19.1	21.6	43.0	15.0	3.2	48.2	6.1	10.9				
Green Ext Time (p_c), s	0.5	0.0	3.5	0.0	0.0	0.0	0.0	1.0				
<b>Intersection Summary</b>												
HCM 2010 Ctrl Delay			54.0									
HCM 2010 LOS			D									
<b>Notes</b>												

























HCM 2010 Signalized Intersection Summary  
 1: Cowan Street & Jefferson Street/Spring Street

River North-High-Level-Option 2C  
 Projected PM

												
Movement	EBL	EBT	EBR	WBL	WBT	WBR	NBL	NBT	NBR	SBL	SBT	SBR
Lane Configurations												
Traffic Volume (veh/h)	239	1596	150	18	724	463	53	80	53	613	62	124
Future Volume (veh/h)	239	1596	150	18	724	463	53	80	53	613	62	124
Number	1	6	16	5	2	12	7	4	14	3	8	18
Initial Q (Qb), veh	0	0	0	0	0	0	0	0	0	0	0	0
Ped-Bike Adj(A_pbT)	1.00		1.00	1.00		1.00	1.00		1.00	1.00		1.00
Parking Bus, Adj	1.00	1.00	1.00	1.00	1.00	1.00	1.00	1.00	1.00	1.00	1.00	1.00
Adj Sat Flow, veh/h/ln	1863	1863	1863	1863	1863	1863	1863	1863	1900	1863	1863	1863
Adj Flow Rate, veh/h	260	1735	163	20	787	0	58	87	58	666	118	101
Adj No. of Lanes	1	2	1	1	3	1	1	1	0	2	1	1
Peak Hour Factor	0.92	0.92	0.92	0.92	0.92	0.92	0.92	0.92	0.92	0.92	0.92	0.92
Percent Heavy Veh, %	2	2	2	2	2	2	2	2	2	2	2	2
Cap, veh/h	409	1777	795	74	2118	659	221	103	68	716	528	449
Arrive On Green	0.10	0.50	0.50	0.00	0.14	0.00	0.03	0.10	0.10	0.20	0.28	0.28
Sat Flow, veh/h	1774	3539	1583	1774	5085	1583	1774	1044	696	3548	1863	1583
Grp Volume(v), veh/h	260	1735	163	20	787	0	58	0	145	666	118	101
Grp Sat Flow(s),veh/h/ln	1774	1770	1583	1774	1695	1583	1774	0	1740	1774	1863	1583
Q Serve(g_s), s	12.2	71.8	8.6	1.0	21.1	0.0	4.4	0.0	12.3	27.7	7.3	7.3
Cycle Q Clear(g_c), s	12.2	71.8	8.6	1.0	21.1	0.0	4.4	0.0	12.3	27.7	7.3	7.3
Prop In Lane	1.00		1.00	1.00		1.00	1.00		0.40	1.00		1.00
Lane Grp Cap(c), veh/h	409	1777	795	74	2118	659	221	0	171	716	528	449
V/C Ratio(X)	0.64	0.98	0.21	0.27	0.37	0.00	0.26	0.00	0.85	0.93	0.22	0.23
Avail Cap(c_a), veh/h	497	1777	795	89	2118	659	221	0	238	757	621	528
HCM Platoon Ratio	1.00	1.00	1.00	0.33	0.33	0.33	1.00	1.00	1.00	1.00	1.00	1.00
Upstream Filter(I)	1.00	1.00	1.00	0.73	0.73	0.00	1.00	0.00	1.00	1.00	1.00	1.00
Uniform Delay (d), s/veh	22.6	36.5	20.7	37.7	46.9	0.0	58.5	0.0	66.5	58.8	41.1	41.1
Incr Delay (d2), s/veh	0.9	16.5	0.6	0.5	0.4	0.0	0.6	0.0	13.8	17.0	0.1	0.1
Initial Q Delay(d3),s/veh	0.0	0.0	0.0	0.0	0.0	0.0	0.0	0.0	0.0	0.0	0.0	0.0
%ile BackOfQ(50%),veh/ln	6.0	39.0	3.9	0.5	10.0	0.0	2.2	0.0	6.6	15.3	3.7	3.2
LnGrp Delay(d),s/veh	23.5	52.9	21.3	38.2	47.2	0.0	59.1	0.0	80.3	75.8	41.2	41.2
LnGrp LOS	C	D	C	D	D		E		F	E	D	D
Approach Vol, veh/h		2158			807			203			885	
Approach Delay, s/veh		47.0			47.0			74.3			67.3	
Approach LOS		D			D			E			E	
Timer	1	2	3	4	5	6	7	8				
Assigned Phs	1	2	3	4	5	6	7	8				
Phs Duration (G+Y+Rc), s	21.5	69.5	37.3	21.7	8.7	82.3	9.5	49.5				
Change Period (Y+Rc), s	7.0	7.0	7.0	7.0	7.0	7.0	4.5	7.0				
Max Green Setting (Gmax), s	22.0	47.5	32.0	20.5	3.0	66.5	5.0	50.0				
Max Q Clear Time (g_c+I1), s	14.2	23.1	29.7	14.3	3.0	73.8	6.4	9.3				
Green Ext Time (p_c), s	0.3	10.3	0.6	0.4	0.0	0.0	0.0	0.7				
<b>Intersection Summary</b>												
HCM 2010 Ctrl Delay			52.8									
HCM 2010 LOS			D									
<b>Notes</b>												

HCM 2010 Signalized Intersection Summary  
 1: Cowan Street & Jefferson Street/Spring Street

























River North-High-Level-Option 3A  
 Projected PM

												
Movement	EBL	EBT	EBR	WBL	WBT	WBR	NBL	NBT	NBR	SBL	SBT	SBR
Lane Configurations												
Traffic Volume (veh/h)	380	1773	150	18	805	606	53	122	53	807	119	315
Future Volume (veh/h)	380	1773	150	18	805	606	53	122	53	807	119	315
Number	1	6	16	5	2	12	7	4	14	3	8	18
Initial Q (Qb), veh	0	0	0	0	0	0	0	0	0	0	0	0
Ped-Bike Adj(A_pbT)	1.00		1.00	1.00		1.00	1.00		1.00	1.00		1.00
Parking Bus, Adj	1.00	1.00	1.00	1.00	1.00	1.00	1.00	1.00	1.00	1.00	1.00	1.00
Adj Sat Flow, veh/h/ln	1863	1863	1863	1863	1863	1863	1863	1863	1900	1863	1863	1863
Adj Flow Rate, veh/h	413	1927	163	20	875	0	58	133	58	877	289	236
Adj No. of Lanes	1	3	1	1	3	1	1	1	0	2	1	1
Peak Hour Factor	0.92	0.92	0.92	0.92	0.92	0.92	0.92	0.92	0.92	0.92	0.92	0.92
Percent Heavy Veh, %	2	2	2	2	2	2	2	2	2	2	2	2
Cap, veh/h	432	2026	631	84	1112	346	235	157	68	873	661	562
Arrive On Green	0.19	0.40	0.40	0.01	0.22	0.00	0.04	0.13	0.13	0.25	0.35	0.35
Sat Flow, veh/h	1774	5085	1583	1774	5085	1583	1774	1231	537	3548	1863	1583
Grp Volume(v), veh/h	413	1927	163	20	875	0	58	0	191	877	289	236
Grp Sat Flow(s),veh/h/ln	1774	1695	1583	1774	1695	1583	1774	0	1768	1774	1863	1583
Q Serve(g_s), s	23.2	47.7	9.0	1.1	21.1	0.0	3.7	0.0	13.7	32.0	15.4	14.7
Cycle Q Clear(g_c), s	23.2	47.7	9.0	1.1	21.1	0.0	3.7	0.0	13.7	32.0	15.4	14.7
Prop In Lane	1.00		1.00	1.00		1.00	1.00		0.30	1.00		1.00
Lane Grp Cap(c), veh/h	432	2026	631	84	1112	346	235	0	226	873	661	562
V/C Ratio(X)	0.96	0.95	0.26	0.24	0.79	0.00	0.25	0.00	0.85	1.00	0.44	0.42
Avail Cap(c_a), veh/h	432	2026	631	102	1112	346	235	0	279	873	716	609
HCM Platoon Ratio	1.00	1.00	1.00	1.00	1.00	1.00	1.00	1.00	1.00	1.00	1.00	1.00
Upstream Filter(I)	1.00	1.00	1.00	0.73	0.73	0.00	1.00	0.00	1.00	1.00	1.00	1.00
Uniform Delay (d), s/veh	32.5	37.9	26.2	41.4	47.9	0.0	46.8	0.0	55.5	49.0	32.0	31.8
Incr Delay (d2), s/veh	31.9	11.4	1.0	0.4	4.2	0.0	0.5	0.0	15.2	31.5	0.2	0.2
Initial Q Delay(d3),s/veh	0.0	0.0	0.0	0.0	0.0	0.0	0.0	0.0	0.0	0.0	0.0	0.0
%ile BackOfQ(50%),veh/ln	18.4	24.4	4.1	0.6	10.3	0.0	1.8	0.0	7.7	19.5	8.0	6.4
LnGrp Delay(d),s/veh	64.4	49.2	27.2	41.8	52.1	0.0	47.3	0.0	70.7	80.5	32.2	32.0
LnGrp LOS	E	D	C	D	D		D		E	F	C	C
Approach Vol, veh/h		2503			895			249			1402	
Approach Delay, s/veh		50.3			51.9			65.2			62.4	
Approach LOS		D			D			E			E	
Timer	1	2	3	4	5	6	7	8				
Assigned Phs	1	2	3	4	5	6	7	8				
Phs Duration (G+Y+Rc), s	32.0	35.4	39.0	23.6	8.6	58.8	9.5	53.1				
Change Period (Y+Rc), s	7.0	7.0	7.0	7.0	7.0	7.0	4.5	7.0				
Max Green Setting (Gmax), s	25.0	24.5	32.0	20.5	3.0	46.5	5.0	50.0				
Max Q Clear Time (g_c+I1), s	25.2	23.1	34.0	15.7	3.1	49.7	5.7	17.4				
Green Ext Time (p_c), s	0.0	1.2	0.0	0.8	0.0	0.0	0.0	1.5				
<b>Intersection Summary</b>												
HCM 2010 Ctrl Delay			54.7									
HCM 2010 LOS			D									
<b>Notes</b>												



























HCM 2010 Signalized Intersection Summary  
 1: Cowan Street & Jefferson Street/Spring Street

River North-High-Level-Option 3B  
 Projected PM

												
Movement	EBL	EBT	EBR	WBL	WBT	WBR	NBL	NBT	NBR	SBL	SBT	SBR
Lane Configurations												
Traffic Volume (veh/h)	437	1773	150	18	805	788	53	145	53	1054	151	392
Future Volume (veh/h)	437	1773	150	18	805	788	53	145	53	1054	151	392
Number	1	6	16	5	2	12	7	4	14	3	8	18
Initial Q (Qb), veh	0	0	0	0	0	0	0	0	0	0	0	0
Ped-Bike Adj(A_pbT)	1.00		1.00	1.00		1.00	1.00		1.00	1.00		1.00
Parking Bus, Adj	1.00	1.00	1.00	1.00	1.00	1.00	1.00	1.00	1.00	1.00	1.00	1.00
Adj Sat Flow, veh/h/ln	1863	1863	1863	1863	1863	1863	1863	1863	1900	1863	1863	1863
Adj Flow Rate, veh/h	475	1927	163	20	875	0	58	158	58	1146	360	295
Adj No. of Lanes	1	3	1	1	3	1	1	1	0	3	1	1
Peak Hour Factor	0.92	0.92	0.92	0.92	0.92	0.92	0.92	0.92	0.92	0.92	0.92	0.92
Percent Heavy Veh, %	2	2	2	2	2	2	2	2	2	2	2	2
Cap, veh/h	502	2348	731	99	1300	405	186	108	40	1295	567	482
Arrive On Green	0.22	0.46	0.46	0.01	0.26	0.00	0.04	0.08	0.08	0.24	0.30	0.30
Sat Flow, veh/h	1774	5085	1583	1774	5085	1583	1774	1301	478	5322	1863	1583
Grp Volume(v), veh/h	475	1927	163	20	875	0	58	0	216	1146	360	295
Grp Sat Flow(s),veh/h/ln	1774	1695	1583	1774	1695	1583	1774	0	1778	1774	1863	1583
Q Serve(g_s), s	27.6	46.0	8.6	1.2	21.7	0.0	4.2	0.0	11.6	29.1	23.3	22.3
Cycle Q Clear(g_c), s	27.6	46.0	8.6	1.2	21.7	0.0	4.2	0.0	11.6	29.1	23.3	22.3
Prop In Lane	1.00		1.00	1.00		1.00	1.00		0.27	1.00		1.00
Lane Grp Cap(c), veh/h	502	2348	731	99	1300	405	186	0	147	1295	567	482
V/C Ratio(X)	0.95	0.82	0.22	0.20	0.67	0.00	0.31	0.00	1.47	0.89	0.63	0.61
Avail Cap(c_a), veh/h	673	2348	731	116	1300	405	211	0	147	1559	633	538
HCM Platoon Ratio	1.00	1.00	1.00	1.00	1.00	1.00	1.00	1.00	1.00	1.00	1.00	1.00
Upstream Filter(I)	1.00	1.00	1.00	0.73	0.73	0.00	1.00	0.00	1.00	1.00	1.00	1.00
Uniform Delay (d), s/veh	31.9	32.7	22.6	39.1	46.9	0.0	55.7	0.0	64.2	51.1	42.0	41.6
Incr Delay (d2), s/veh	16.9	3.4	0.7	0.3	2.1	0.0	0.9	0.0	242.8	5.0	1.1	1.0
Initial Q Delay(d3),s/veh	0.0	0.0	0.0	0.0	0.0	0.0	0.0	0.0	0.0	0.0	0.0	0.0
%ile BackOfQ(50%),veh/ln	20.3	22.1	3.9	0.6	10.4	0.0	2.1	0.0	15.6	14.8	12.2	9.9
LnGrp Delay(d),s/veh	48.8	36.0	23.3	39.4	48.9	0.0	56.7	0.0	307.0	56.1	43.1	42.6
LnGrp LOS	D	D	C	D	D		E		F	E	D	D
Approach Vol, veh/h		2565			895			274			1801	
Approach Delay, s/veh		37.6			48.7			254.0			51.3	
Approach LOS		D			D			F			D	
Timer	1	2	3	4	5	6	7	8				
Assigned Phs	1	2	3	4	5	6	7	8				
Phs Duration (G+Y+Rc), s	37.6	42.8	41.1	18.6	8.7	71.6	10.0	49.6				
Change Period (Y+Rc), s	7.0	7.0	7.0	7.0	7.0	7.0	4.5	7.0				
Max Green Setting (Gmax), s	44.0	15.4	41.0	11.6	3.0	56.4	7.5	47.6				
Max Q Clear Time (g_c+I1), s	29.6	23.7	31.1	13.6	3.2	48.0	6.2	25.3				
Green Ext Time (p_c), s	1.0	0.0	3.0	0.0	0.0	6.0	0.0	1.8				
<b>Intersection Summary</b>												
HCM 2010 Ctrl Delay			54.6									
HCM 2010 LOS			D									
<b>Notes</b>												























HCM 2010 Signalized Intersection Summary  
 1: Cowan Street & Jefferson Street/Spring Street

River North-High-Level-Option 3C  
 Projected PM

												
Movement	EBL	EBT	EBR	WBL	WBT	WBR	NBL	NBT	NBR	SBL	SBT	SBR
Lane Configurations												
Traffic Volume (veh/h)	308	1773	150	18	805	380	53	93	53	502	81	218
Future Volume (veh/h)	308	1773	150	18	805	380	53	93	53	502	81	218
Number	1	6	16	5	2	12	7	4	14	3	8	18
Initial Q (Qb), veh	0	0	0	0	0	0	0	0	0	0	0	0
Ped-Bike Adj(A_pbT)	1.00		1.00	1.00		1.00	1.00		1.00	1.00		1.00
Parking Bus, Adj	1.00	1.00	1.00	1.00	1.00	1.00	1.00	1.00	1.00	1.00	1.00	1.00
Adj Sat Flow, veh/h/ln	1863	1863	1863	1863	1863	1863	1863	1863	1900	1863	1863	1863
Adj Flow Rate, veh/h	335	1927	163	20	875	0	58	101	58	546	200	162
Adj No. of Lanes	1	2	1	1	3	1	1	1	0	2	1	1
Peak Hour Factor	0.92	0.92	0.92	0.92	0.92	0.92	0.92	0.92	0.92	0.92	0.92	0.92
Percent Heavy Veh, %	2	2	2	2	2	2	2	2	2	2	2	2
Cap, veh/h	498	1859	832	68	2105	655	217	120	69	598	484	412
Arrive On Green	0.12	0.53	0.53	0.02	0.83	0.00	0.03	0.11	0.11	0.17	0.26	0.26
Sat Flow, veh/h	1774	3539	1583	1774	5085	1583	1774	1112	638	3548	1863	1583
Grp Volume(v), veh/h	335	1927	163	20	875	0	58	0	159	546	200	162
Grp Sat Flow(s),veh/h/ln	1774	1770	1583	1774	1695	1583	1774	0	1750	1774	1863	1583
Q Serve(g_s), s	15.7	78.8	8.2	1.0	6.8	0.0	4.4	0.0	13.4	22.7	13.4	12.7
Cycle Q Clear(g_c), s	15.7	78.8	8.2	1.0	6.8	0.0	4.4	0.0	13.4	22.7	13.4	12.7
Prop In Lane	1.00		1.00	1.00		1.00	1.00		0.36	1.00		1.00
Lane Grp Cap(c), veh/h	498	1859	832	68	2105	655	217	0	189	598	484	412
V/C Ratio(X)	0.67	1.04	0.20	0.29	0.42	0.00	0.27	0.00	0.84	0.91	0.41	0.39
Avail Cap(c_a), veh/h	884	1859	832	83	2105	655	217	0	286	662	621	528
HCM Platoon Ratio	1.00	1.00	1.00	2.00	2.00	2.00	1.00	1.00	1.00	1.00	1.00	1.00
Upstream Filter(I)	1.00	1.00	1.00	0.73	0.73	0.00	1.00	0.00	1.00	1.00	1.00	1.00
Uniform Delay (d), s/veh	19.3	35.6	18.8	37.5	8.2	0.0	57.2	0.0	65.6	61.3	46.0	45.8
Incr Delay (d2), s/veh	0.6	31.0	0.5	0.6	0.4	0.0	0.7	0.0	8.3	15.3	0.2	0.2
Initial Q Delay(d3),s/veh	0.0	0.0	0.0	0.0	0.0	0.0	0.0	0.0	0.0	0.0	0.0	0.0
%ile BackOfQ(50%),veh/ln	7.7	46.2	3.7	0.5	3.2	0.0	2.2	0.0	6.9	12.4	6.9	5.6
LnGrp Delay(d),s/veh	19.9	66.6	19.4	38.1	8.6	0.0	57.8	0.0	73.9	76.5	46.2	46.0
LnGrp LOS	B	F	B	D	A		E		E	E	D	D
Approach Vol, veh/h		2425			895			217			908	
Approach Delay, s/veh		56.9			9.3			69.6			64.4	
Approach LOS		E			A			E			E	
Timer	1	2	3	4	5	6	7	8				
Assigned Phs	1	2	3	4	5	6	7	8				
Phs Duration (G+Y+Rc), s	25.4	69.1	32.3	23.2	8.7	85.8	9.5	46.0				
Change Period (Y+Rc), s	7.0	7.0	7.0	7.0	7.0	7.0	4.5	7.0				
Max Green Setting (Gmax), s	51.0	18.5	28.0	24.5	3.0	66.5	5.0	50.0				
Max Q Clear Time (g_c+I1), s	17.7	8.8	24.7	15.4	3.0	80.8	6.4	15.4				
Green Ext Time (p_c), s	0.7	6.8	0.6	0.8	0.0	0.0	0.0	1.1				
<b>Intersection Summary</b>												
HCM 2010 Ctrl Delay			49.5									
HCM 2010 LOS			D									
<b>Notes</b>												

























HCM 2010 Signalized Intersection Summary  
 1: Cowan Street & Jefferson Street/Spring Street

River North-High-Level-Option 4A  
 Projected PM

												
Movement	EBL	EBT	EBR	WBL	WBT	WBR	NBL	NBT	NBR	SBL	SBT	SBR
Lane Configurations												
Traffic Volume (veh/h)	265	1596	150	18	724	736	53	111	53	984	104	159
Future Volume (veh/h)	265	1596	150	18	724	736	53	111	53	984	104	159
Number	1	6	16	5	2	12	7	4	14	3	8	18
Initial Q (Qb), veh	0	0	0	0	0	0	0	0	0	0	0	0
Ped-Bike Adj(A_pbT)	1.00		1.00	1.00		1.00	1.00		1.00	1.00		1.00
Parking Bus, Adj	1.00	1.00	1.00	1.00	1.00	1.00	1.00	1.00	1.00	1.00	1.00	1.00
Adj Sat Flow, veh/h/ln	1863	1863	1863	1863	1863	1863	1863	1863	1900	1863	1863	1863
Adj Flow Rate, veh/h	288	1735	163	20	787	0	58	121	58	1070	158	143
Adj No. of Lanes	1	3	1	1	3	1	1	1	0	2	1	1
Peak Hour Factor	0.92	0.92	0.92	0.92	0.92	0.92	0.92	0.92	0.92	0.92	0.92	0.92
Percent Heavy Veh, %	2	2	2	2	2	2	2	2	2	2	2	2
Cap, veh/h	365	1883	586	84	1263	393	246	140	67	1064	739	629
Arrive On Green	0.13	0.37	0.37	0.01	0.25	0.00	0.04	0.12	0.12	0.30	0.40	0.40
Sat Flow, veh/h	1774	5085	1583	1774	5085	1583	1774	1191	571	3548	1863	1583
Grp Volume(v), veh/h	288	1735	163	20	787	0	58	0	179	1070	158	143
Grp Sat Flow(s),veh/h/ln	1774	1695	1583	1774	1695	1583	1774	0	1762	1774	1863	1583
Q Serve(g_s), s	16.4	45.7	10.1	1.2	19.3	0.0	4.0	0.0	14.0	42.0	7.8	8.4
Cycle Q Clear(g_c), s	16.4	45.7	10.1	1.2	19.3	0.0	4.0	0.0	14.0	42.0	7.8	8.4
Prop In Lane	1.00		1.00	1.00		1.00	1.00		0.32	1.00		1.00
Lane Grp Cap(c), veh/h	365	1883	586	84	1263	393	246	0	207	1064	739	629
V/C Ratio(X)	0.79	0.92	0.28	0.24	0.62	0.00	0.24	0.00	0.87	1.01	0.21	0.23
Avail Cap(c_a), veh/h	482	1883	586	100	1263	393	247	0	252	1064	785	667
HCM Platoon Ratio	1.00	1.00	1.00	1.00	1.00	1.00	1.00	1.00	1.00	1.00	1.00	1.00
Upstream Filter(I)	1.00	1.00	1.00	0.73	0.73	0.00	1.00	0.00	1.00	1.00	1.00	1.00
Uniform Delay (d), s/veh	33.2	42.1	30.9	41.9	46.8	0.0	51.6	0.0	60.7	49.0	27.8	28.0
Incr Delay (d2), s/veh	4.5	8.9	1.2	0.4	1.7	0.0	0.5	0.0	19.7	28.9	0.1	0.1
Initial Q Delay(d3),s/veh	0.0	0.0	0.0	0.0	0.0	0.0	0.0	0.0	0.0	0.0	0.0	0.0
%ile BackOfQ(50%),veh/ln	8.5	22.9	4.6	0.6	9.2	0.0	2.0	0.0	7.9	24.8	4.0	3.7
LnGrp Delay(d),s/veh	37.7	51.1	32.1	42.3	48.5	0.0	52.1	0.0	80.4	77.9	27.9	28.1
LnGrp LOS	D	D	C	D	D		D		F	F	C	C
Approach Vol, veh/h		2186			807			237			1371	
Approach Delay, s/veh		47.9			48.3			73.5			66.9	
Approach LOS		D			D			E			E	
Timer	1	2	3	4	5	6	7	8				
Assigned Phs	1	2	3	4	5	6	7	8				
Phs Duration (G+Y+Rc), s	25.8	41.8	49.0	23.4	8.7	58.8	9.9	62.6				
Change Period (Y+Rc), s	7.0	7.0	7.0	7.0	7.0	7.0	4.5	7.0				
Max Green Setting (Gmax), s	28.0	22.0	42.0	20.0	3.0	47.0	5.5	59.0				
Max Q Clear Time (g_c+I1), s	18.4	21.3	44.0	16.0	3.2	47.7	6.0	10.4				
Green Ext Time (p_c), s	0.4	0.6	0.0	0.5	0.0	0.0	0.0	1.0				
<b>Intersection Summary</b>												
HCM 2010 Ctrl Delay			55.0									
HCM 2010 LOS			D									
<b>Notes</b>												

























HCM 2010 Signalized Intersection Summary  
 1: Cowan St & Jefferson St/Spring St

River North-High-Level-Option 4B  
 Projected PM

												
Movement	EBL	EBT	EBR	WBL	WBT	WBR	NBL	NBT	NBR	SBL	SBT	SBR
Lane Configurations												
Traffic Volume (veh/h)	285	1596	150	18	724	1028	53	135	53	1381	137	186
Future Volume (veh/h)	285	1596	150	18	724	1028	53	135	53	1381	137	186
Number	1	6	16	5	2	12	7	4	14	3	8	18
Initial Q (Qb), veh	0	0	0	0	0	0	0	0	0	0	0	0
Ped-Bike Adj(A_pbT)	1.00		1.00	1.00		1.00	1.00		1.00	1.00		1.00
Parking Bus, Adj	1.00	1.00	1.00	1.00	1.00	1.00	1.00	1.00	1.00	1.00	1.00	1.00
Adj Sat Flow, veh/h/ln	1863	1863	1863	1863	1863	1863	1863	1863	1900	1863	1863	1863
Adj Flow Rate, veh/h	310	1735	163	20	787	0	58	147	58	1501	189	176
Adj No. of Lanes	1	3	1	1	3	1	1	1	0	3	1	1
Peak Hour Factor	0.92	0.92	0.92	0.92	0.92	0.92	0.92	0.92	0.92	0.92	0.92	0.92
Percent Heavy Veh, %	2	2	2	2	2	2	2	2	2	2	2	2
Cap, veh/h	371	1806	562	82	1112	346	257	169	67	1515	742	631
Arrive On Green	0.15	0.36	0.36	0.01	0.22	0.00	0.04	0.13	0.13	0.28	0.40	0.40
Sat Flow, veh/h	1774	5085	1583	1774	5085	1583	1774	1272	502	5322	1863	1583
Grp Volume(v), veh/h	310	1735	163	20	787	0	58	0	205	1501	189	176
Grp Sat Flow(s),veh/h/ln	1774	1695	1583	1774	1695	1583	1774	0	1774	1774	1863	1583
Q Serve(g_s), s	17.0	43.4	9.6	1.1	18.6	0.0	3.6	0.0	14.7	36.5	8.8	9.8
Cycle Q Clear(g_c), s	17.0	43.4	9.6	1.1	18.6	0.0	3.6	0.0	14.7	36.5	8.8	9.8
Prop In Lane	1.00		1.00	1.00		1.00	1.00		0.28	1.00		1.00
Lane Grp Cap(c), veh/h	371	1806	562	82	1112	346	257	0	235	1515	742	631
V/C Ratio(X)	0.84	0.96	0.29	0.24	0.71	0.00	0.23	0.00	0.87	0.99	0.25	0.28
Avail Cap(c_a), veh/h	448	1806	562	101	1112	346	263	0	273	1515	775	659
HCM Platoon Ratio	1.00	1.00	1.00	1.00	1.00	1.00	1.00	1.00	1.00	1.00	1.00	1.00
Upstream Filter(I)	1.00	1.00	1.00	1.00	1.00	0.00	1.00	0.00	1.00	1.00	1.00	1.00
Uniform Delay (d), s/veh	32.7	41.0	30.1	41.6	47.0	0.0	46.2	0.0	55.3	46.3	26.2	26.5
Incr Delay (d2), s/veh	9.4	13.8	1.3	0.6	3.8	0.0	0.4	0.0	20.8	20.9	0.1	0.1
Initial Q Delay(d3),s/veh	0.0	0.0	0.0	0.0	0.0	0.0	0.0	0.0	0.0	0.0	0.0	0.0
%ile BackOfQ(50%),veh/ln	9.2	22.5	4.4	0.6	9.1	0.0	1.8	0.0	8.6	20.9	4.6	4.3
LnGrp Delay(d),s/veh	42.2	54.8	31.4	42.2	50.8	0.0	46.7	0.0	76.1	67.2	26.3	26.6
LnGrp LOS	D	D	C	D	D		D		E	E	C	C
Approach Vol, veh/h		2208			807			263			1866	
Approach Delay, s/veh		51.3			50.6			69.6			59.2	
Approach LOS		D			D			E			E	
Timer	1	2	3	4	5	6	7	8				
Assigned Phs	1	2	3	4	5	6	7	8				
Phs Duration (G+Y+Rc), s	26.4	35.4	44.0	24.2	8.6	53.2	9.4	58.8				
Change Period (Y+Rc), s	7.0	7.0	7.0	7.0	7.0	7.0	4.5	7.0				
Max Green Setting (Gmax), s	25.0	20.0	37.0	20.0	3.0	42.0	5.4	54.1				
Max Q Clear Time (g_c+I1), s	19.0	20.6	38.5	16.7	3.1	45.4	5.6	11.8				
Green Ext Time (p_c), s	0.4	0.0	0.0	0.5	0.0	0.0	0.0	1.2				
<b>Intersection Summary</b>												
HCM 2010 Ctrl Delay			55.0									
HCM 2010 LOS			D									
<b>Notes</b>												

HCM 2010 Signalized Intersection Summary  
 1: Cowan Street & Jefferson Street/Spring Street

River North-High-Level-Option 4C  
 Projected PM

												
Movement	EBL	EBT	EBR	WBL	WBT	WBR	NBL	NBT	NBR	SBL	SBT	SBR
Lane Configurations												
Traffic Volume (veh/h)	248	1596	150	18	724	485	53	90	53	644	76	136
Future Volume (veh/h)	248	1596	150	18	724	485	53	90	53	644	76	136
Number	1	6	16	5	2	12	7	4	14	3	8	18
Initial Q (Qb), veh	0	0	0	0	0	0	0	0	0	0	0	0
Ped-Bike Adj(A_pbT)	1.00		1.00	1.00		1.00	1.00		1.00	1.00		1.00
Parking Bus, Adj	1.00	1.00	1.00	1.00	1.00	1.00	1.00	1.00	1.00	1.00	1.00	1.00
Adj Sat Flow, veh/h/ln	1863	1863	1863	1863	1863	1863	1863	1863	1900	1863	1863	1863
Adj Flow Rate, veh/h	270	1735	163	20	787	0	58	98	58	700	132	116
Adj No. of Lanes	1	2	1	1	3	1	1	1	0	2	1	1
Peak Hour Factor	0.92	0.92	0.92	0.92	0.92	0.92	0.92	0.92	0.92	0.92	0.92	0.92
Percent Heavy Veh, %	2	2	2	2	2	2	2	2	2	2	2	2
Cap, veh/h	428	1729	773	68	2011	626	225	114	68	743	553	470
Arrive On Green	0.10	0.49	0.49	0.01	0.40	0.00	0.03	0.10	0.10	0.21	0.30	0.30
Sat Flow, veh/h	1774	3539	1583	1774	5085	1583	1774	1098	650	3548	1863	1583
Grp Volume(v), veh/h	270	1735	163	20	787	0	58	0	156	700	132	116
Grp Sat Flow(s),veh/h/ln	1774	1770	1583	1774	1695	1583	1774	0	1748	1774	1863	1583
Q Serve(g_s), s	13.1	73.3	8.8	1.0	16.6	0.0	4.4	0.0	13.2	29.1	8.0	8.3
Cycle Q Clear(g_c), s	13.1	73.3	8.8	1.0	16.6	0.0	4.4	0.0	13.2	29.1	8.0	8.3
Prop In Lane	1.00		1.00	1.00		1.00	1.00		0.37	1.00		1.00
Lane Grp Cap(c), veh/h	428	1729	773	68	2011	626	225	0	182	743	553	470
V/C Ratio(X)	0.63	1.00	0.21	0.29	0.39	0.00	0.26	0.00	0.86	0.94	0.24	0.25
Avail Cap(c_a), veh/h	728	1729	773	83	2011	626	225	0	239	757	621	528
HCM Platoon Ratio	1.00	1.00	1.00	1.00	1.00	1.00	1.00	1.00	1.00	1.00	1.00	1.00
Upstream Filter(I)	1.00	1.00	1.00	0.73	0.73	0.00	1.00	0.00	1.00	1.00	1.00	1.00
Uniform Delay (d), s/veh	22.9	38.4	21.9	38.4	32.4	0.0	57.7	0.0	66.1	58.4	39.9	40.0
Incr Delay (d2), s/veh	0.6	22.5	0.6	0.6	0.4	0.0	0.6	0.0	16.9	19.5	0.1	0.1
Initial Q Delay(d3),s/veh	0.0	0.0	0.0	0.0	0.0	0.0	0.0	0.0	0.0	0.0	0.0	0.0
%ile BackOfQ(50%),veh/ln	6.4	41.2	4.0	0.5	7.9	0.0	2.2	0.0	7.2	16.3	4.2	3.7
LnGrp Delay(d),s/veh	23.4	60.9	22.5	39.1	32.8	0.0	58.3	0.0	83.0	77.9	40.0	40.1
LnGrp LOS	C	F	C	D	C		E		F	E	D	D
Approach Vol, veh/h		2168			807			214			948	
Approach Delay, s/veh		53.3			33.0			76.3			68.0	
Approach LOS		D			C			E			E	
Timer	1	2	3	4	5	6	7	8				
Assigned Phs	1	2	3	4	5	6	7	8				
Phs Duration (G+Y+Rc), s	22.7	66.3	38.4	22.6	8.7	80.3	9.5	51.5				
Change Period (Y+Rc), s	7.0	7.0	7.0	7.0	7.0	7.0	4.5	7.0				
Max Green Setting (Gmax), s	41.0	28.5	32.0	20.5	3.0	66.5	5.0	50.0				
Max Q Clear Time (g_c+I1), s	15.1	18.6	31.1	15.2	3.0	75.3	6.4	10.3				
Green Ext Time (p_c), s	0.5	6.2	0.3	0.5	0.0	0.0	0.0	0.8				
<b>Intersection Summary</b>												
HCM 2010 Ctrl Delay			53.9									
HCM 2010 LOS			D									
<b>Notes</b>												

APPENDIX E  
TRIP GENERATION CALCULATIONS

## TRIP GENERATION

## River North Mixed-Use Development-Phase 1 Evaluation

Office – 3,029,000 square feet

Use ITE Land Use Code 710 and associated trip generation rates for 24-hour total trips and peak hour trips.

Average Daily Traffic – Use Average Rate for Average Daily Traffic on a Weekday

$$LN(T) = 0.76 LN(X/1000) + 3.68$$

$$LN(T) = 0.76 LN(3,029) + 3.68$$

$$T = 17,538$$

A.M. Peak Hour - Use Average Rate for AM Peak Hour of the Adjacent Street (between 7:00 AM and 9:00 AM)

$$LN(T) = 0.8 LN(X/1000) + 1.57$$

$$LN(T) = 0.8 LN(3,029) + 1.57$$

$$T = 2,930$$

$$\text{Enter} = 0.88 (2,930) = 2,578$$

$$\text{Exit} = 0.12 (2,930) = 352$$

P.M. Peak Hour - Use Average Rate for PM Peak Hour of the Adjacent Street (between 4:00 PM and 6:00 PM)

$$T = 1.12 (X/1000) + 78.45$$

$$T = 1.12 (3,029) + 78.45$$

$$T = 3,471$$

$$\text{Enter} = 0.17 (3,471) = 590$$

$$\text{Exit} = 0.83 (3,471) = 2,881$$

## TRIP GENERATION

## River North Mixed-Use Development – Phase 1 Evaluation

Apartment – 1,735 Units

Use ITE Land Use Code 220 and associated trip generation rates for 24-hour total trips and peak hour trips.

Average Daily Traffic – Use the Fitted Curve Equation for Average Daily Traffic on a Weekday

$$T = 6.06 (X) + 123.56$$

$$T = 6.06 (1,735) + 123.56$$

$$T = 10,638$$

A.M. Peak Hour - Use the Fitted Curve Equation for the AM Peak Hour of the Adjacent Street Traffic (one hour between 7:00 AM and 9:00 AM) on a Weekday

$$T = 0.49 (X) + 3.73$$

$$T = 0.49 (1,735) + 3.73$$

$$T = 854$$

$$\text{Enter} = 0.20 (854) = 171$$

$$\text{Exit} = 0.80 (854) = 683$$

P.M. Peak Hour - Use the Fitted Curve Equation for the PM Peak Hour of the Adjacent Street Traffic (one hour between 4:00 PM and 6:00 PM) on a Weekday

$$T = 0.55 (X) + 17.65$$

$$T = 0.55 (1,735) + 17.65$$

$$T = 972$$

$$\text{Enter} = 0.65 (972) = 632$$

$$\text{Exit} = 0.35 (972) = 340$$



## TRIP GENERATION

## River North Mixed-Use Development – Phase 1 Evaluation

Hotel – 550 Rooms

Use ITE Land Use Code 310 and associated trip generation rates for 24-hour total trips and peak hour trips.

Average Daily Traffic – Use the Fitted Curve Equation for Average Daily Traffic on a Weekday

$$T = 8.95 (X) - 373.16$$

$$T = 8.95 (550) - 373.16$$

$$T = 4,549$$

A.M. Peak Hour - Use the Fitted Curve Equation for the AM Peak Hour of the Adjacent Street Traffic (one hour between 7:00 AM and 9:00 AM) on a Weekday

$$T = 0.53 (X)$$

$$T = 0.53 (550)$$

$$T = 292$$

$$\text{Enter} = 0.59 (292) = 172$$

$$\text{Exit} = 0.41 (292) = 120$$

P.M. Peak Hour - Use the Fitted Curve Equation for the PM Peak Hour of the Adjacent Street Traffic (one hour between 4:00 PM and 6:00 PM) on a Weekday

$$T = 0.60 (X)$$

$$T = 0.60 (550)$$

$$T = 330$$

$$\text{Enter} = 0.51 (330) = 168$$

$$\text{Exit} = 0.49 (330) = 162$$

## TRIP GENERATION

River North Mixed-Use Development – Phase 1 Evaluation

Specialty Retail – 200,000 square feet

Use ITE Land Use Code 826 and associated trip generation rates for 24-hour total trips and peak hour trips.

Average Daily Traffic

$$T = 42.78 (X/1000) + 37.66$$

$$T = 42.78 (200) + 37.66$$

$$T = 8,594$$

AM Peak Hour – None in the Trip Gen Manual- Assumed 50% of the PM Peak Hour.

PM Peak Hour - Use PM Peak Hour of the Adjacent Street (between 4:00 and 6:00 PM)

$$T = 2.40(X/1000) + 21.48$$

$$T = 2.40(200) + 21.48$$

$$T = 501$$

$$\text{Enter} = 0.44 (501) = 221$$

$$\text{Exit} = 0.56 (501) = 281$$

## TRIP GENERATION

## River North Mixed-Use Development – Phase 1 Evaluation

Quality Restaurant – 27,840 square feet

Use ITE Land Use Code 931 and associated trip generation rates for 24-hour total trips and peak hour trips.

Average Daily Traffic

$$T = 89.95 (X/1000)$$

$$T = 89.95 (27.840)$$

$$T = 2,504$$

A.M. Peak Hour - Use average rate for the AM Peak Hour of the Adjacent Street (between 7:00 AM and 9:00 AM). Directional Distribution not provided, use AM Peak Hour of Generator distribution.

$$T = 0.81 (X/1000)$$

$$T = 0.81 (27.840)$$

$$T = 23$$

$$\text{Enter} = 0.82 (23) = 18$$

$$\text{Exit} = 0.18 (23) = 5$$

P.M. Peak Hour - Use average rate for the PM Peak Hour of the Adjacent Street (between 4:00 PM and 6:00 PM)

$$T = 7.49 (X/1000)$$

$$T = 7.49 (27.840)$$

$$T = 209$$

$$\text{Enter} = 0.67 (209) = 140$$

$$\text{Exit} = 0.33 (209) = 69$$

## TRIP GENERATION

## River North Mixed-Use Development – Phase 1 Evaluation

High Turnover Restaurant – 27,840 square feet

Use ITE Land Use Code 932 and associated trip generation rates for 24-hour total trips and peak hour trips.

Average Daily Traffic

$$T = 127.15 (X/1000)$$

$$T = 127.15 (27.840)$$

$$T = 3,540$$

A.M. Peak Hour - Use average rate for the AM Peak Hour of the Adjacent Street (between 7:00 AM and 9:00 AM). Directional Distribution not provided, use AM Peak Hour of Generator distribution.

$$T = 10.81 (X/1000)$$

$$T = 10.81 (27.840)$$

$$T = 301$$

$$\text{Enter} = 0.55 (301) = 166$$

$$\text{Exit} = 0.45 (301) = 135$$

P.M. Peak Hour - Use average rate for the PM Peak Hour of the Adjacent Street (between 4:00 PM and 6:00 PM)

$$T = 9.85 (X/1000)$$

$$T = 9.85 (27.840)$$

$$T = 274$$

$$\text{Enter} = 0.60 (274) = 164$$

$$\text{Exit} = 0.40 (274) = 110$$

## TRIP GENERATION

River North Mixed-Use Development – Phase 1 Evaluation

Coffee/Donut Shop without Drive-Through Window – 2,320 square feet

Use ITE Land Use Code 936 and associated trip generation rates peak hour trips.

Average Daily Traffic – Assume AM peak hour trips account for 20% of average daily traffic

T = 5 (AM Peak Hour)

T = 5 (251)

T = 1,257

A.M. Peak Hour – Use AM Peak Hour of the Adjacent Street (between 7:00 AM and 9:00 AM)

T = 108.38 (X/1000)

T = 108.38 (2.320)

T = 251

Enter = 0.51 (251) = 128

Exit = 0.49 (251) = 123

P.M. Peak Hour - Use PM Peak Hour of the Adjacent Street (between 4:00 PM and 6:00 PM)

T = 40.75 (X/1000)

T = 40.75 (2.320)

T = 95

Enter = 0.50 (95) = 47

Exit = 0.50 (95) = 47

NCHRP 684 Internal Trip Capture Estimator

Project Name:	River North	Organization:	KCI Technologies, Inc
Project Location:		Performed By:	
Scenario Description:		Date:	
Analysis Year:		Checked By:	
Analysis Period:	AM Peak Hour	Date:	

Table 1-A: Base Vehicle-Trip Generation Estimates (Single-Use Site Estimate)

Land Use	Development Data			Estimated Vehicle-Trips		
	ITE LUCs1	Quantity	Units	Total	Entering	Exiting
Office	710	0	kfs	2,930	2,578	352
Retail	826	0	kfs	251	110	140
Restaurant	932/931/ 936	0	kfs	575	312	263
Cinema/Entertainment	445	0	seats	0	0	0
Residential	220,230	0	du	854	171	683
Hotel	310	0	rooms	292	172	120
All Other Uses	-	0	-	0	0	0
Total	-	-	-	4,901	3,344	1,557

Table 2-A: Mode Split and Vehicle Occupancy Estimates

Land Use	Entering Trips			Exiting Trips		
	Veh. Occ.	% Transit	% Non-Motorized	Veh. Occ.	% Transit	% Non-Motorized
Office	1.00	0%	0%	1.00	0%	0%
Retail	1.00	0%	0%	1.00	0%	0%
Restaurant	1.00	0%	0%	1.00	0%	0%
Cinema/Entertainment	1.00	0%	0%	1.00	0%	0%
Residential	1.00	0%	0%	1.00	0%	0%
Hotel	1.00	0%	0%	1.00	0%	0%
All Other Uses2	1.00	0%	0%	1.00	0%	0%
Total						

Table 3-A: Average Land Use Interchange Distances (Feet Walking Distance)

Origin (From)	Destination (To)					
	Office	Retail	Restaurant	Cinema/Entertainment	Residential	Hotel
Office	0	500	500	500	500	500
Retail	500	0	500	500	500	500
Restaurant	500	500	0	500	500	500
Cinema/Entertainment	500	500	500	0	500	500
Residential	500	500	500	500	0	500
Hotel	500	500	500	500	500	0

Table 4-A: Internal Person-Trip Origin-Destination Matrix

Origin (From)	Destination (To)					
	Office	Retail	Restaurant	Cinema/Entertainment	Residential	Hotel
Office		35	72	0	0	0
Retail	41		18	0	3	0
Restaurant	81	9		0	9	7
Cinema/Entertainment	0	0	0		0	0
Residential	102	7	62	0		0
Hotel	77	4	11	0	0	

Table 5-A: Computations Summary

	Total	Entering	Exiting
All Person-Trips	4,901	3,344	1,557
Internal Trips	1,076	538	538
Internal Capture Percentage	22.0%	16.1%	34.5%
External Vehicle-Trips3	3,825	2,806	1,019
External Transit-Trips4	0	0	0
External Non-motorized Trips4	0	0	0

Table 6-A: Internal Trip Capture Percentages by Land Use

Land Use	Entering Trips	Exiting Trips
Office	11.7%	30.4%
Retail	49.9%	44.2%
Restaurant	52.2%	40.4%
Cinema/Entertainment	#DIV/0!	#DIV/0!
Residential	7.0%	25.0%
Hotel	4.1%	77.0%

1 Land Use Codes (LUCs) from Trip Generation Informational Report, ITE.  
 2 Total estimate for all other land uses at mixed-use development site-not subject to internal trip capture computations in this estimator.  
 3 Vehicle-trips computed using the mode split and vehicle occupancy values provided in Table 2-A  
 4 Person-trips

NCHRP 684 Internal Trip Capture Estimator

Project Name:		Organization:	KCI Technologies, Inc
Project Location:		Performed By:	
Scenario Description:		Date:	
Analysis Year:		Checked By:	
Analysis Period:	PM Peak Hour	Date:	

Table 1-P: Base Vehicle-Trip Generation Estimates (Single-Use Site Estimate)

Land Use	Development Data			Estimated Vehicle-Trips		
	ITE LUCs1	Quantity	Units	Total	Entering	Exiting
Office	710	0	ksf	3,471	590	2,881
Retail	826	0	ksf	501	221	281
Restaurant	932/931/ 936	0	ksf	577	352	226
Cinema/Entertainment	445	0	seats	0	0	0
Residential	220,230	0	du	972	632	340
Hotel	310	0	rooms	330	168	162
All Other Uses	-	0	-	0	0	0
Total	-	-	-	5,852	1,962	3,889

Table 2-P: Mode Split and Vehicle Occupancy Estimates

Land Use	Entering Trips			Exiting Trips		
	Veh. Occ.	% Transit	% Non-Motorized	Veh. Occ.	% Transit	% Non-Motorized
Office	1.00	0%	0%	1.00	0%	0%
Retail	1.00	0%	0%	1.00	0%	0%
Restaurant	1.00	0%	0%	1.00	0%	0%
Cinema/Entertainment	1.00	0%	0%	1.00	0%	0%
Residential	1.00	0%	0%	1.00	0%	0%
Hotel	1.00	0%	0%	1.00	0%	0%
All Other Uses2	1.00	0%	0%	1.00	0%	0%
Total						

Table 3-P: Average Land Use Interchange Distances (Feet Walking Distance)

Origin (From)	Destination (To)					
	Office	Retail	Restaurant	Cinema/Entertainment	Residential	Hotel
Office	0	500	500	500	500	500
Retail	500	0	500	500	500	500
Restaurant	500	500	0	500	500	500
Cinema/Entertainment	500	500	500	0	500	500
Residential	500	500	500	500	0	500
Hotel	500	500	500	500	500	0

Table 4-P: Internal Person-Trip Origin-Destination Matrix

Origin (From)	Destination (To)					
	Office	Retail	Restaurant	Cinema/Entertainment	Residential	Hotel
Office		18	7	0	95	0
Retail	6		81	0	73	14
Restaurant	7	93		0	41	16
Cinema/Entertainment	0	0	0		0	0
Residential	14	22	49	0		10
Hotel	0	4	18	0	0	

Table 5-P: Computations Summary

	Total	Entering	Exiting
All Person-Trips	5,852	1,962	3,889
Internal Trips	1,136	568	568
Internal Capture Percentage	19.4%	28.9%	14.6%
External Vehicle-Trips3	4,716	1,394	3,321
External Transit-Trips4	0	0	0
External Non-motorized Trips4	0	0	0

Table 6-P: Internal Trip Capture Percentages by Land Use

Land Use	Entering Trips	Exiting Trips
Office	4.6%	4.2%
Retail	62.1%	62.0%
Restaurant	44.1%	69.5%
Cinema/Entertainment	#DIV/0!	#DIV/0!
Residential	33.1%	27.9%
Hotel	23.8%	13.6%

1 Land Use Codes (LUCs) from Trip Generation Informational Report, ITE.

2 Total estimate for all other land uses at mixed-use development site-not subject to internal trip capture computations in this estimator.

3 Vehicle-trips computed using the mode split and vehicle occupancy values provided in Table 2-P

4 Person-trips

**TRIP GENERATION  
TOTAL SITE-GENERATED TRAFFIC**

LAND USE	SIZE	DAILY TRAFFIC	GENERATED TRAFFIC			
			AM PEAK HR.		PM PEAK HR.	
			ENTER	EXIT	ENTER	EXIT
Office	3,029,000 s.f.	17,538	2,578	352	590	2,881
Specialty Retail	200,000 s.f.	8,594	110	140	221	281
Restaurant	58,000 s.f.	7,301	312	263	352	226
Apartments	1,735 d.u.	10,638	171	683	632	340
Hotel	550 rooms	4,549	172	120	168	162
<b>TOTAL</b>		<b>48,620</b>	<b>3,343</b>	<b>1,558</b>	<b>1,963</b>	<b>3,890</b>

**TRIP GENERATION  
INTERNAL SITE-GENERATED TRAFFIC**

Assumes: 20% Internal (for daily traffic)

use internal capture spread sheet for AM and PM reduction factor

LAND USE	SIZE	DAILY TRAFFIC	GENERATED TRAFFIC			
			AM PEAK HR.		PM PEAK HR.	
			ENTER	EXIT	ENTER	EXIT
Office	3,029,000 s.f.	3,508	301	107	27	120
Specialty Retail	200,000 s.f.	1,719	55	62	137	174
Restaurant	58,000 s.f.	1,460	163	106	155	157
Apartments	1,735 d.u.	2,128	12	171	209	95
Hotel	550 rooms	910	7	92	40	22
<b>TOTAL</b>		<b>9,725</b>	<b>538</b>	<b>538</b>	<b>568</b>	<b>568</b>

**TRIP GENERATION  
EXTERNAL SITE-GENERATED TRAFFIC**

Assumes: 20% Internal (for daily traffic)

LAND USE	SIZE	DAILY TRAFFIC	GENERATED TRAFFIC			
			AM PEAK HR.		PM PEAK HR.	
			ENTER	EXIT	ENTER	EXIT
Office	3,029,000 s.f.	14,030	2,277	245	563	2,761
Specialty Retail	200,000 s.f.	6,875	55	78	84	107
Restaurant	58,000 s.f.	5,841	149	157	197	69
Apartments	1,735 d.u.	8,510	159	512	423	245
Hotel	550 rooms	3,639	165	28	128	140
<b>TOTAL</b>		<b>38,895</b>	<b>2,805</b>	<b>1,020</b>	<b>1,395</b>	<b>3,322</b>



TRIP GENERATION ALTERNATE MODE SITE-GENERATED TRAFFIC							
LAND USE	SIZE	DAILY TRAFFIC	GENERATED TRAFFIC				
			AM PEAK HR.		PM PEAK HR.		
			ENTER	EXIT	ENTER	EXIT	
Office	3,029,000 s.f.	702	114	12	28	138	Use:  5% 5% 5% 5% 5%
Specialty Retail	200,000 s.f.	344	3	4	4	5	
Restaurant	58,000 s.f.	292	7	8	10	3	
Apartments	1,735 d.u.	426	8	26	21	12	
Hotel	550 rooms	182	8	1	6	7	
<b>TOTAL</b>		<b>1,338</b>	<b>124</b>	<b>24</b>	<b>42</b>	<b>146</b>	

TRIP GENERATION NEW SITE-GENERATED VEHICULAR TRAFFIC						
LAND USE	SIZE	DAILY TRAFFIC	GENERATED TRAFFIC			
			AM PEAK HR.		PM PEAK HR.	
			ENTER	EXIT	ENTER	EXIT
Office	3,029,000 s.f.	13,328	2,163	233	535	2,623
Specialty Retail	200,000 s.f.	6,531	52	74	80	102
Restaurant	58,000 s.f.	5,549	142	149	187	66
Apartments	1,735 d.u.	8,084	151	486	402	233
Hotel	550 rooms	3,457	157	27	122	133
<b>TOTAL</b>		<b>36,949</b>	<b>2,665</b>	<b>969</b>	<b>1,326</b>	<b>3,157</b>