



January 27, 2023

Metro Waste Services
1600 2nd Ave N
Landfill and Processing Facility Applications
Nashville, TN 37208

RE: Triune Residuals Management, LLC
Solid Waste Processing Permit Application
Permit-By-Rule Jackson Law Package
Triune Centennial Processing Facility

To whom it may concern:

On behalf of Triune Residuals Management LLC, Barge Design Solutions (Barge) is submitting this application for a Solid Waste Processing (SWP) permit for the processing, sorting, separating, and reducing of construction and demolition waste to recover recyclable products. The facility is located in Davidson County at 7133 Centennial Boulevard in Nashville and is therefore subject to Jackson Law. The attached package addresses all required criteria under Jackson Law for the permitting of processing facilities in a county that has enacted the Jackson Law such as Davidson County.

If you have any questions concerning this proposal, please call Jason Repsher at 615-252-4481.

Sincerely,

A handwritten signature in black ink, appearing to read "Josh Beckler".

Josh Beckler, PE

Barge Design Solutions, Inc.

Barge Project # 3712202



Triune Centennial
Processing Facility
Jackson Law Permit By Rule
Notification Package

7133 Centennial Boulevard, Nashville, TN

Prepared For: Triune Residuals Management, LLC

PREPARED BY



615 3rd Avenue South, Suite 700

Nashville, TN 37210

BARGE # 3722202

CONTENTS

1.0	Introduction	1
2.0	Jackson Law Criteria	2
2.1	Waste Type	2
2.2	Processing Methods	2
2.3	Noise and Odor Impact	3
2.4	Property Value Impact	3
2.5	Transportation Infrastructure Impact	3
2.6	Economic Impact	4
2.7	Zoning Compatibility	4
2.8	Public Health, Safety or Welfare Impact	4
3.0	Permit By Rule Criteria	4

APPENDICES

- Appendix 1 – Permit By Rule Notification
- Appendix 2 – USGS Topographic Map
- Appendix 3 – Facility Layout
- Appendix 4 – Environmental Site Investigation
- Appendix 5 – FEMA Floodplain Map
- Appendix 6 – IPaC Report
- Appendix 7 – Financial Assurance
- Appendix 8 – Facility Calculation

1.0 INTRODUCTION

Barge Design Solutions, Inc. (Barge) was asked to compile the information necessary for a Permit-by-Rule application for a new processing facility to meet the requirements of the Tennessee Department of Environment and Conservation (TDEC).

Triune Residuals Management is committed to environmentally sound practices involving the collection, processing, recycling, reclamation, transfer, and the disposal of solid waste. This document provides a narrative of the Triune Centennial operations in conjunction with a new Permit-By-Rule Notification and topographic location map presented in Appendixes 1 and 2 respectively, for the property located at 7133 Centennial Boulevard, Nashville, Tennessee. The ‘Jackson Law’ requirements for processing facilities are addressed in Section 2.

The purpose of this facility is to process, sort, separate, and reduce inside an enclosed building the incoming construction and demolition (C&D) waste to recover recyclable products such as

metal, cardboard, drywall, and clean fill. Recycled products such as cardboard or wood/green waste may be baled and stored in bale form as they are inert materials. The residual materials will then be transported to a fully permitted Class III Landfill.

The current site operates under a RMPF (Recovered Materials Processing Facility) notification to accept and recover materials such as cardboard, glass, plastics, shingles, scrap tires, wood/green waste, scrap metal, and metal products from separated C&D waste and other source separate materials from 60 to 90 containers per day. The site is zoned IR and is surrounded by other IR zoned properties. No residential property is within a 1-mile radius of the site.

This facility is and will continue to be operated with trained personnel with clearly posted signs for entry locations, hours of operation and contact information. Personnel will be equipped with communication devices to maintain traffic control, facility security and immediate access to emergency personnel if needed. All records required by this Permit-by-Rule will be kept in order at the site.

The full Environmental Site Investigation is provided in Appendix 4. The current and proposed office, scale house, tipping floor, processing facility and storage areas will be existing construction and located well away from the stream and wetland areas defined on the hydrologic determination at the site.

The following narrative sections have been correlated to the Tennessee Department of Environment and Conservation – Division of Solid Waste Management (Division) regulations for ease of reference.

2.0 JACKSON LAW CRITERIA

The following sections address TDEC Rule 0400-11-01-.02 Part (1)(c)(2)(vii) for the permitting of processing facilities in a County which has enacted the 'Jackson Law' such as Davidson County.

2.1 Waste Type

The proposed facility will process, sort, recycle, reduce, and reclaim C&D debris as well as other products approved for processing and recovery by TDEC. These are similar to current activities already performed at the site under the RMPF designation.

2.2 Processing Methods

All loading or unloading of materials will occur within the on-site building for solid waste processing and recovery and on paved surfaces as required. All waste handling will be on a concrete surface within the building. However, a separate 'hot load' area has been designated outside the building to provide an area to address incoming loads and waste that may pose a fire risk to the facility. This area is required by the regulations but is seldomly needed during normal operations as loads are inspected prior to placement on the tipping floor.

The facility has been specifically designed with a tipping floor, material processing and storage area to minimize material handling, allow ease of recovery for recycled materials, block or minimize prevailing wind issues. Again, all processing and recovered materials will be stored within a building or in appropriate containers and paved storage areas.

The processing area for operation of the sorting, separating, recycling, reduction, and reclamation is a complex process and may be adjusted periodically to allow for addition of additional recycling

processing improvements in operations and mechanical separation systems.

2.3 Noise and Odor Impact

Facility operations will solely take place inside the building at the facility and thereby reduce noise potential.

The existing site's location in a purely industrial area limits its impact on the surrounding area. A rail line wraps the entire western and northern property lines while across Centennial Boulevard is the Visteon (former Ford Glass) plant. The nearest residential properties are to the south and southeast of the site, approximately 1.15 miles from the site. Trucks entering and exiting the site will blend with the current truck traffic associated with the site with no additional noise impact to the surrounding area. The proposed processing operation is comparable with current operations on the site with the potential for addition of specific equipment for further recycling and reduction to meet upcoming goals for C&D diversion.

See Appendix 8 for Noise Measurements taken on-site which show existing noise levels from Centennial Boulevard, Tune airport and helicopter training traffic as well as adjacent industrial activity to the site.

All inbound and outbound materials will be in appropriate containers with all recovery processing occurring within the building.

The existing building orientation and tipping floor is opposite the prevailing wind direction to minimize wind-blown annoyances prior to vehicle entry to the building.

The facility will be operated to provide adequate ventilation for odor control and employee safety. The operator will prevent nuisance odors from leaving the boundary of the facility. If nuisance odors are found to be passing the facility boundary, the facility operator may suspend operations until the nuisance is abated or immediately take action to abate the nuisance. No odor issues have been noted with current operations of the RMPF operation.

2.4 Property Value Impact

There is no anticipation of any negative impacts to property values in surrounding areas to change due to the proposed facility. The property has been under industrial use for over 50 years and is surrounded by industrial development in the area. Industrial property values in the area have continued to skyrocket in valuation due to the use of many former industrial sites as high density residential areas.

The closest residential area is approximately 1.15 miles from the site.

2.5 Transportation Infrastructure Impact

The proposed waste processing facility is anticipated to generate 20 additional vehicles per day accessing the site already operating as a RMPF operation at 7133 Centennial Boulevard. Based upon the guidance in standard industry evaluation for traffic studies, the proposed number of additional site trips will not cause a significant degradation in the level of service on Centennial Boulevard, or Briley Parkway. Please see the Transportation Infrastructure Impact analysis located in Appendix 8. This site is also located along a railroad spur and is uniquely positioned to allow transportation of materials by rail.

2.6 Economic Impact

EPA's 2020 Recycling Economic Information Report states that ferrous metals, construction and demolition (C&D) and nonferrous metals represent the top three contributors of the total economic impact within the recycling industry. A considerable portion of the economic impacts for the recycling sector occur indirectly rather than a direct result of their production. These impacts include employment, wage, and tax contributions, which directly contribute to the community. These are the direct objectives of the Triune Centennial facility to serve the Nashville area. This facility currently employs 12 employees for the various facility operations that take place on site. The potential for additional equipment and operational throughput could generate an additional 8 to 12 jobs depending on equipment, material rates and other factors.

2.7 Zoning Compatibility

This site is zoned Industrial Restrictive (IR) and located in an area off Briley Parkway and Centennial Boulevard that is characterized by industrial development and no residential areas. This site is also located along a railroad spur and is uniquely positioned to allow transportation of materials by rail.

2.8 Public Health, Safety or Welfare Impact

All inbound and outbound materials will be in appropriate containers with all recovery processing occurring within a building. Recycled products that are recovered from the process will also be stored within the buildings or in containers designed for recycled material storage and eventually transferred for beneficial reuse or disposal.

Like the current RMPF operation, the facility will not be open to the general public but will be open to other business traffic. This facility will have clearly visible and legible signs at the points of public access which indicate the hours of operation, the type of material accepted and emergency number. The entire facility is already fenced along Centennial Boulevard with gate systems at each entry and exit point. The western property line adjoins a creek system and railroad which provides an excellent additional access deterrent. Additionally, required landscaping per Metro Nashville Planning ordinances can provide a further access deterrent and provide screening for the facility.

3.0 PERMIT BY RULE CRITERIA

- (a) All permit by rule facilities shall keep any records that are required by these rules and a copy of its permit by rule authorization at the facility or at another location approved by the Department. Notwithstanding any other provision of this rule, except for subparagraph (1)(c) of this rule, and provided they are not excluded pursuant to part (1)(b)3 of this rule, the following classes of activities shall be deemed to have a permit by rule if the conditions listed are met:**
- i) The operator complies with the notification requirement of subparagraph (b) of this paragraph;**
 - ii) The facility is constructed, operated, maintained, and closed in such a manner as to minimize:**
 - l) The propagation, harborage, or attraction of flies, rodents, or other disease vectors;**

Recyclable loads will be separated, processed, sorted, and reduced for material recovery. Non-recyclable material on such loads will be placed in another container and taken to a permitted solid waste disposal facility. Material will be handled in a timely manner as it enters the facility it will be placed onto the concrete tipping floor and processed.

While there is no anticipated opportunity for the propagation, harborage, or attraction of flies, rodents or other disease vectors, pest control is available at the facility. Currently no issues have been identified with the RMPF operation in regards to these activities.

This SWP will process non-hazardous materials for recycling from primarily roll-off containers on concrete floor inside of the on-site building to allow for processing and reclamation of the materials. Recycled products that are recovered from the process will also be stored under cover or on concrete or asphalt areas in containers designed for recycled material storage and eventually transferred for beneficial reuse. Disposal of residual materials will be hauled via truck to approved landfills in the local area.

II) The potential for explosions or uncontrolled fires;

Material loads are to be placed onto the concrete tipping floor for inspection for any non-compliant materials. Any hazards identified will be immediately conveyed to the Site Manager. Non-compliant waste will remain untouched, and all personnel evacuated from the immediate area if necessary, until the material has been cleared for transport and disposal or has been removed from the facility for proper characterization and disposal. In case of a fire the Nashville Fire Department will be contacted immediately by calling 911. The facility will not accept any type of explosive materials. Fire prevention and protection are being practiced and all fire extinguisher points are clearly visible and up to date.

Additional procedures will be developed to respond to accidental fires at this facility with training of site staff. Fire extinguishers will be strategically placed throughout the facility and personnel will be trained in the use of this equipment. Should a load of material be received at this facility that is burning, smoking or at a temperature that will potentially cause a fire, it will be removed from inside the structure if possible, to a designated area outside the building where it will be easier to contain, control and to extinguish.

The site grounds will be maintained on a regular basis to prevent accumulation of vegetation. Procedures have been developed that address accidental fires in section xvi of this document.

III) The potential for releases of solid wastes or solid waste constituents to the environment except in a manner authorized by state and local air pollution control, water pollution control, and/or waste management agencies;

Surface and groundwater will be protected by handling and processing all waste inside the process building with all inbound and outbound materials in appropriate containers. Compliance with all state and local surface water regulations will be strictly adhered to. Any necessary sewer industrial discharge permits will also be obtained.

All facility traffic will be on asphalt or compacted gravel surfaces to be maintained by typical street sweeping methods. Sufficient water will be used on these surfaces to avoid dust as needed. All

equipment will be cleaned and maintained to minimize emissions and to reduce tracking. Traffic will be limited to commercial users that will follow strict traffic flow procedures.

Air pollution concerns resulting from exhaust (particularly diesel) mobile equipment such as trucks and loaders, driving on unpaved or dusty surfaces, and cleanup operations such as street sweeping will be addressed with industry accepted measures.

The following measures will be implemented to minimize the impact of potential air pollution at the site.

- Paved traffic carrying surfaces to and from the processing area
- Paved surfaces and tipping floor will be kept clean
- Street sweeping operations will use sufficient water to avoid dust. Water will be used only as necessary.
- Equipment engines will receive regular maintenance including tune-ups to minimize emissions.
- Truck bodies and tires will be cleaned as necessary to reduce tracking onto streets.

IV) The potential for harm to the public through unauthorized or uncontrolled access;

The site will have trained staff on site during operating hours and will control unauthorized access to the facility. Facility staff will monitor the facility for security purposes during operations. In addition, the property fence will be enhanced with limited and controlled access via gates during operational hours. All access gates will be locked when no facility or security personnel are on the site. Additionally, the facility will not be open to the public.

iii) The facility has an artificial or natural barrier which completely surrounds the facility and a means to control entry, at all times, through the gate or other entrances to the facility;

All vehicles entering the facility will access the site through the entrance at Centennial Boulevard. The existing gates, terrain, and vegetation will be utilized to restrict unauthorized access to the facility. The facility is fenced with a gate system at the existing entrance and the proposed exit point. The entire north and west sides of the facility contains a stream system and railroad line which provides an excellent natural access barrier as do the dense existing trees and steep grades. The facility will have additional fencing and gates installed at the main and secondary access points to the site and along the access road to the facility. Gates will be closed and locked when no facility personnel are present at the site.

iv) The facility, if open to the public, has clearly visible and legible signs at the points of public access which indicate the hours of operation, the general types of waste materials that either will or will not be accepted, emergency telephone numbers, schedule of charges (if applicable), and other necessary information;

The facility will not be open to the public.

v) Trained personnel are always present during operating hours to operate the facility;

Trained staff will be on-site during all operating hours for the facility. These employees are trained

to comply with all regulations concerning the operation of this facility. Documentation of training will be kept on-site and in the main personnel files.

vi) The facility has adequate sanitary facilities, emergency communications (e.g., telephone), and shelter available for personnel;

The processing facility will have several restrooms and breakrooms available for staff use. Each employee is equipped with a cellular telephone or two-way radio(s) capable of summoning emergency assistance on-site.

vii) The facility's access road(s) and parking area(s) are constructed so as to be accessible in all weather conditions;

The facility has been designed with all-weather access for the site via paved surfaces with sufficient parking for site personnel, truck and container staging and overall site access. Paving consisting of asphalt and compacted gravel as noted on the facility layout plan have been designed to handle the truck traffic anticipated at the facility.

viii) Except for composting facilities utilizing landscaping and land clearing wastes only, all waste handling (including loading and unloading) at the facility is conducted on paved surfaces;

All loading or unloading of materials will occur within the on-site building processing and recovery with stored materials on paved surfaces as required. All material handling will be on a concrete surface within the building. The proposed facility plan includes existing and proposed asphalt or concrete surfaces which covers a large amount of the facility as noted in the plans provided in Appendix 3.

ix) There is no storage of solid wastes at the facility except in the containers, bins, lined pits or on paved surfaces, designated for such storage;

There will not be storage of materials at the facility except in the containers and bins or on concrete surfaces, under cover, that are designated for such storage. Material will be received and placed on the tipping floor for processing and placement in either the material recovery process lines to recycled and used in applicable areas, run through the mechanical processing equipment and metal recovery equipment and other processes. All recovered materials will be stored within the building or in appropriate containers and paved storage areas.

x) Except for incinerators or energy recovery units, there is no burning of solid wastes at the facility;

No burning of solid wastes will occur at the facility.

xi) There is no scavenging of solid wastes at the facility and any salvaging is conducted at safe, designated areas and times;

Scavenging will not be allowed at the facility. Salvaging activities will be prevented after hours by the locked gate as well as the physical/natural barriers and perimeter fencing. Recycling and recovery efforts along with recovered material storage will be conducted within the building or stored in appropriate containers.

xii) Wind dispersal of solid wastes at or from the facility is adequately controlled, including the daily collection and proper disposal of windblown litter and other loose, unconfined solid wastes;

Blowing litter is not normally associated with these materials. Wind dispersal of materials will be controlled at this facility by site personnel regularly performing litter patrols to collect litter on site, around the perimeter of the site, and at the entrance into the site.

xiii) All liquids which either drain from solid wastes or are created by washdown of equipment at the facility go to either:

- I) A wastewater treatment facility permitted to receive such wastewaters under T.C.A. §§ 69-3-101 et seq. (Tennessee Water Quality Control Act, or**
- II) Other methods approved by the Commissioner.**

Any liquid generated from the processing of the materials for recycling and recovery will be collected and managed separate from stormwater should constituents of concern from the to be acquired TMSPP permit indicate an issue with discharge. Should treatment be necessary the water will be pumped and hauled to the local POTW or disposed of through the Metro Nashville sewer system under an industrial discharge permit.

Current RMPF operations have not needed any water collection as the materials are under cover of the building.

xiv) The facility receives no special wastes unless:

- I) Such receipt has been specifically approved in writing by the Department, and**
- II) Special procedures and/or equipment are utilized to adequately confine and segregate the special wastes;**

No special wastes are anticipated to be received at the material recovery processing facility. Should a material source be designated by the Tennessee Department of Environment and Conservation as a special waste then all appropriate approvals shall be obtained prior to acceptance of the material at the designated facility. Such material would be handled as defined by that approval and confined from other operations as required.

xv) The operator can demonstrate, at the request of the Commissioner, that alternative arrangements (e.g., contracts with other facilities) for the proper processing or disposal of the solid wastes his facility handles are available in the event his facility cannot operate;

The owner will have arrangements with other approved facilities to address any materials unable to be recovered or recycled by the facility as necessary and appropriate financial assurance on file, as is already in place for the RMPF operation, with TDEC to allow proper cleanup of the site should activities cease.

xvi) The facility has properly maintained and located fire suppression equipment (e.g., fire extinguishers, water hoses) continuously available in sufficient quantities to control accidental fires that may occur;

Procedures have been developed to respond to accidental fires at the facility. The following paragraphs detail the equipment available for firefighting and the procedures developed for response to accidental fires and or potential explosions.

FIRE SUPPRESSION EQUIPMENT

Fire extinguishers are located on each piece of heavy equipment and throughout the facility at locations and frequencies compliant with OSHA requirements for fire safety. The fire extinguishers will be properly maintained and recharged as necessary. Processing facility personnel will be properly trained in the use of the fire extinguishers.

Additional fire suppression controls as required by code will be installed at the facility.

FIRE RESPONSE PROCEDURES

In the case of a fire, the fire department will be notified via 911 and will subsequently be dispatched to the site. The nearest fire station to the site is the Nashville Fire Department Station 23 at 6215 Centennial Boulevard, Nashville, Tennessee 37209 approximately 1.2 miles from the site.

xvii) All waste residues resulting from processing activities at the facility are managed in accordance with this Chapter or Chapter 0400-12-01 (Hazardous Waste Management), whichever is applicable, and/or with any other applicable state or federal regulations governing waste management;

No hazardous waste will be accepted at the facility. Should suspect material be noted during material inspections the load will be refused and diverted to an appropriate disposal facility. Should incidental hazardous waste be noted and if it is already on the tipping floor the load will be separated from the non-hazardous materials and stored in an appropriate container to await characterization and final disposition by the generator of the material. The facility has ample storage areas to allow for this process.

xviii) The facility is finally closed by removal of all solid wastes and solid waste residues for proper disposal. The operator must notify the Division Director in writing of his completion of closure of the facility. Such notification must include a certification by the operator that the facility has been closed by removal of all the solid waste and residues. Within 21 days of the receipt of such notice the Division Director shall inspect the facility to verify that closure has been completed. Within 10 days of such verification, the Commissioner shall approve the closure in writing to the operator. Closure shall not be considered final and complete until such approval has been made.

Should the facility close, the owner shall remove all materials from the site for either reclamation or disposal to appropriate permitted facilities as required by this paragraph. The facility concrete floor will be cleaned, and all fluid will be handled with appropriate or approved methods of disposal. All notifications shall also be filed with the TDEC Division of Solid Waste Management Director in a timely manner.

xix) New solid waste processing facilities shall not be located in wetlands, unless the owner or operator makes the applicable demonstrations to the Commissioner as referenced at subparagraph (2)(p) of Rule 0400-11-01-.04.

The existing facility building is not located in a wetland. The environmental site investigation is attached as Appendix 4.

xx) The facility must not be located in a 100-year floodplain unless it is demonstrated to the satisfaction of the Commissioner that:

I) Location in the floodplain will not restrict the flow of the 100-year flood nor reduce the temporary water storage capacity of the floodplain.

The facility is not within a 100-year floodplain as shown in Appendix 5.

II) The facility is designed, constructed, operated, and maintained to prevent washout of any solid waste.

The proposed C&D processing facility is not located in an existing floodplain. The facility will be constructed such that contact water will be collected either as leachate or stormwater and managed so as to prevent accidental release to the environment.

xxi) The facility does not:

I) Cause or contribute to the taking of any endangered or threatened species of plants, fish, or wildlife; or

II) Result in the destruction or adverse modification of the critical habitat of endangered or threatened species.

This facility does not cause or contribute to the taking of any endangered or threatened species of plants, fish, or wildlife; or result in the destruction or adverse modification of the critical habitat of endangered or threatened species. See Appendix 6 for iPaC Resource List.

xxii) The owner/operator may not store solid waste until the processing equipment has been installed on-site and is ready for use.

Prior to any additional recycling or recovery operations all necessary equipment will be on-site and operational at this facility.

xxiii) The owner/operator of a solid waste processing facility which has a solid waste storage capacity of 1000 cubic yards or greater shall file with the Commissioner a performance bond or equivalent cash or securities, payable to the State of Tennessee. Such financial assurance is intended to ensure that adequate financial resources are available to the Commissioner to insure the proper operation, closure, and post closure care of the facility. The types of financial assurance instruments that are acceptable are those specified in subparagraph (3)(d) of Rule 0400-11-01-.03. Such financial assurance shall meet the criteria set forth in T.C.A. § 68-211-116(a) and at subparagraph (3)(b) of Rule 0400-11-01-.03.

The owner/operator shall provide financial assurance as required by the Tennessee Department of Environment and Conservation for this SWP. Storage associated with the processing operations is limited to approximately 9,850 CY overall based upon the area of operations inside

the building and possible outdoor storage containers. Complete financial assurance calculations are provided in Appendix 7 which have already been accepted for the current RMPF operations.

xxiv) The owners or operators proposing a new solid waste processing facility that handles putrescible wastes located within 10,000 feet (3,048 meters) of any airport runway end used by turbojet aircraft or within 5,000 feet (1,524 meters) of any airport runway end used only by piston-type aircraft must include in the permit-by-rule notification a demonstration that the facility does not pose a bird hazard to aircraft. The owners or operators proposing a new solid waste processing facility that handles putrescible wastes located within a five-mile radius of any airport runway end used by turbojet or piston-type aircraft must notify the affected airport and the appropriate Federal Aviation Administration (FAA) office.

No putrescible materials will be located or stored outside other than in appropriate containers, as such birds would not be attracted to the facility. FAA will be provided notice of the facility and information provided that C&D materials are not defined as putrescible.

**APPENDIX 1 –
Permit By Rule Notification**



STATE OF TENNESSEE
 DEPARTMENT OF ENVIRONMENT AND CONSERVATION
 DIVISION OF SOLID WASTE MANAGEMENT
 WILLIAM R. SNODGRASS TENNESSEE TOWER
 312 ROSA L. PARKS AVENUE, 14TH FLOOR
 NASHVILLE, TN 37243

SOLID WASTE PERMIT-BY-RULE NOTIFICATION

1. YES NO

D? NEW PROCESSING FACILITY (\$1,000)
 NEW TRANSFER STATION (\$500)

2. TYPE OF PERMIT- BY- RULE REQUESTED

COMPOST FACILITY LAND APPLICATION TIRE STORAGE FACILITY NEW FACILITY
 CONVENIENCE CENTER PROCESSING FACILITY TRANSFER STATION AMENDMENT TO EXISTING PERMIT

PROCESSING FACILITIES ONLY
 IS THIS FACILITY SUBJECT TO "THE JACKSON LAW"? YES NO

3. FACILITY INFORMATION

FULL LEGAL NAME OF FACILITY: **Triune Centennial Processing Facility**

PHYSICAL LOCATION OR ADDRESS OF FACILITY: **7133 Centennial Blvd. Nashville TN 37209**

FACILITY MAILING ADDRESS: **5800 One Perkins Place, Suite 6A Baton Rouge LA 70808**

FACILITY EMAIL: **info@trinitybusinessgroup.net**

FACILITY LOCATION COUNTY: **Davidson**

LATITUDE (DECIMAL DEGREES): **36.181785**

LONGITUDE (DECIMAL DEGREES): **-86.878430**

FACILITY MANAGER OR SITE OPERATOR: **Blake Brian** PHONE (WITH AREA CODE): **(225) 766-1443** AFFILIATION OF SITE OPERATOR (IF DIFFERENT FROM PERMITTEE): **General Manager**

4. APPLICANT (PERMITTEE)

APPLICANT NAME: **Triune Residuals Management, LLC** PHONE (WITH AREA CODE): **(225) 766-1443** EMAIL: **info@trinitybusinessgroup.net**

RESPONSIBLE OFFICIAL / TITLE: **Sidney Brian** PHONE (WITH AREA CODE): **(225) 766-1443** EMAIL: **info@trinitybusinessgroup.net**

RESPONSIBLE OFFICIAL MAILING ADDRESS: **5800 One Perkins Place, Suite 6A Baton Rouge LA 70808**

LANDOWNER NAME: **Triune Residuals Management, LLC** LANDOWNER MAILING ADDRESS: **5800 One Perkins Place, Suite 6A Baton Rouge LA 70808**

LANDOWNER SIGNATURE: *[Signature]* DATE: **1.17.23**

5. WASTE HANDLING

DESCRIPTION OF ACTIVITIES AND WASTES HANDLED OR PROCESSED: The purpose of this processing facility is to process, sort, separate, and reduce the incoming construction and demolition (C&D) waste to recover recyclable products such as metal, cardboard, drywall, and clean fill. The residual materials will be transported to a fully permitted Class III landfill in the local area approved accept the material.

AMOUNT OF WASTE HANDLED, PROCESSED OR STORED

1,200	9,850
WEIGHT TONS / DAY	VOLUME YARDS / DAY
	STORAGE MAX CU YARDS

6. CERTIFICATION REQUIRED

I certify under penalty of law that this document and all attachments were prepared by me, or under my direction or supervision. The submitted information is to the best of my knowledge and belief, true, accurate, and complete. I am aware that there are significant penalties for submitting false information, including the possibility of fine and imprisonment. As specified in Tennessee Code Annotated Section 39-16-702(a)(4), this declaration is made under penalty of perjury.

SIGNATURE OF RESPONSIBLE OFFICIAL: *[Signature]* PRINTED NAME: **Sidney G Beir**

TITLE: **General Manager** DATE: **Jan 17, 2023**

SIGNATURE OF NOTARY: *[Signature]* DATE COMMISSION EXPIRES: **03-21-2023**

(NOTARY SEAL) **ASHLEY A. GLASS** STATE OF TENNESSEE NOTARY PUBLIC SUMNER COUNTY

INSTRUCTIONS FOR SOLID WASTE PERMIT-BY-RULE NOTIFICATION

COMPLETE THIS FORM FOR EACH FACILITY THAT IS PROCESSING AND/OR DISPOSING OF SOLID WASTE IN TENNESSEE. IF MULTIPLE FACILITIES EXIST OR ARE PLANNED, DESCRIBE EACH FACILITY AND ITS WASTES ON A SEPARATE FORM. SUBMIT COMPLETED DOCUMENT TO THE RESPECTIVE FIELD OFFICE IN YOUR AREA.

1. REVIEW FEE

TYPE OF PERMIT-BY-RULE WITH FEES

A FEE IS ONLY REQUIRED FOR A NEW PROCESSING FACILITY OR A NEW TRANSFER FACILITY. MAKE CHECKS PAYABLE TO: "TREASURER, STATE OF TENNESSEE"

2. TYPE OF PERMIT- BY- RULE REQUESTED

TYPE OF PERMIT-BY-RULE

CHECK TYPE OF PERMIT-BY-RULE REQUESTED AND DISTINGUISH IF THIS REQUEST IS FOR AN ALREADY EXISTING FACILITY OR A REQUEST FOR A NEW FACILITY.

NEW PROCESSING FACILITIES MUST DETERMINE IF THEY ARE SUBJECT TO LOCAL APPROVAL THROUGH THE "JACKSON LAW" AS SPECIFIED IN TENNESSEE CODE ANNOTATED § 68-211-701.

3. FACILITY INFORMATION

FULL LEGAL NAME OF FACILITY

ENTER THE FULL LEGAL NAME FOR THIS SITE TO DISTINGUISH IT FROM ANY OTHER SITE THE APPLICANT OR ORGANIZATION MAY OWN OR OPERATE IN TENNESSEE.

PHYSICAL LOCATION

INFORMATION (ADDRESS, DIRECTIONS) THAT WILL AID IN FINDING THIS SITE (NO PO BOX NUMBERS) PROVIDE COUNTY WHERE SITE IS LOCATED. PROVIDE LATITUDE AND LONGITUDE FOR SITE LOCATION IN DECIMAL DEGREES.

FACILITY MAILING ADDRESS

PROVIDE COMPLETE MAILING ADDRESS FOR THIS SITE

NAME OF FACILITY OR SITE MANAGER OR SITE OPERATOR

NAME AND PHONE NUMBER OF PERSON WHO IS RESPONSIBLE FOR THE DIRECTION OF ACTIVITIES AT THIS SITE

AFFILIATION OF SITE OPERATOR (IF DIFFERENT FROM PERMITTEE)

IF SITE IS OPERATED BY PERSON OR ENTITY OTHER THAN PERMITTEE, GIVE NAME OF PERSON, CORPORATION ETC.

4. APPLICANT (PERMITTEE)

APPLICANT NAME

NAME OF LEGAL ENTITY MAKING APPLICATION FOR PERMIT. THIS NAME WILL BE THE PERMITTEE OF RECORD.

RESPONSIBLE OFFICIAL

PERSON AUTHORIZED TO COMPLETE THIS APPLICATION AND WHO MAY BE CONTACTED BY TDEC FOR ANY FURTHER INFORMATION.

LANDOWNER NAME

PERSON(S) OR ORGANIZATION(S) OF THE IMMEDIATE PROPERTY OWNER(S). ATTACH LETTER FROM LANDOWNER(S).

LANDOWNER SIGNATURE(S)

LANDOWNER(S) MUST SIGN AND DATE APPLICATION

5. WASTE HANDLING

AMOUNT OF WASTE HANDLED / PROCESSED / STORED

PROVIDE AN ESTIMATE OF THE DAILY WEIGHT (IN TONS) AND/OR VOLUME (IN CU YARDS/DAY) THAT WILL BE HANDLED AT THE FACILITY. INDICATE THE MAXIMUM AMOUNT OF WASTE THAT CAN BE STORED (IN CUBIC YARDS).

6. CERTIFICATION REQUIRED

CERTIFICATION

AFTER ALL DOCUMENTS HAVE BEEN COMPILED FOR SUBMISSION TO THE DIVISION, THE MANAGER OR OWNER RESPONSIBLE FOR THE SITE MUST SIGN THE CERTIFICATION AND GIVE DATE AND TITLE. THIS SIGNATURE MUST BE NOTARIZED.

**APPENDIX 2 –
USGS Topographic Map**

USER:KBECKLER
 FILE:\corp_data\proj\371220203_PROJECT_EXECUTION\06_PERMITS\Processing Facility_PBR\Jackson Law PBR Package\Appendices\Appendix 2 - USGS Topo Map\EX - USGS QUAD MAP.dwg
 SAVID: 12/18/2022
 PLOTTED: 12/17/2023

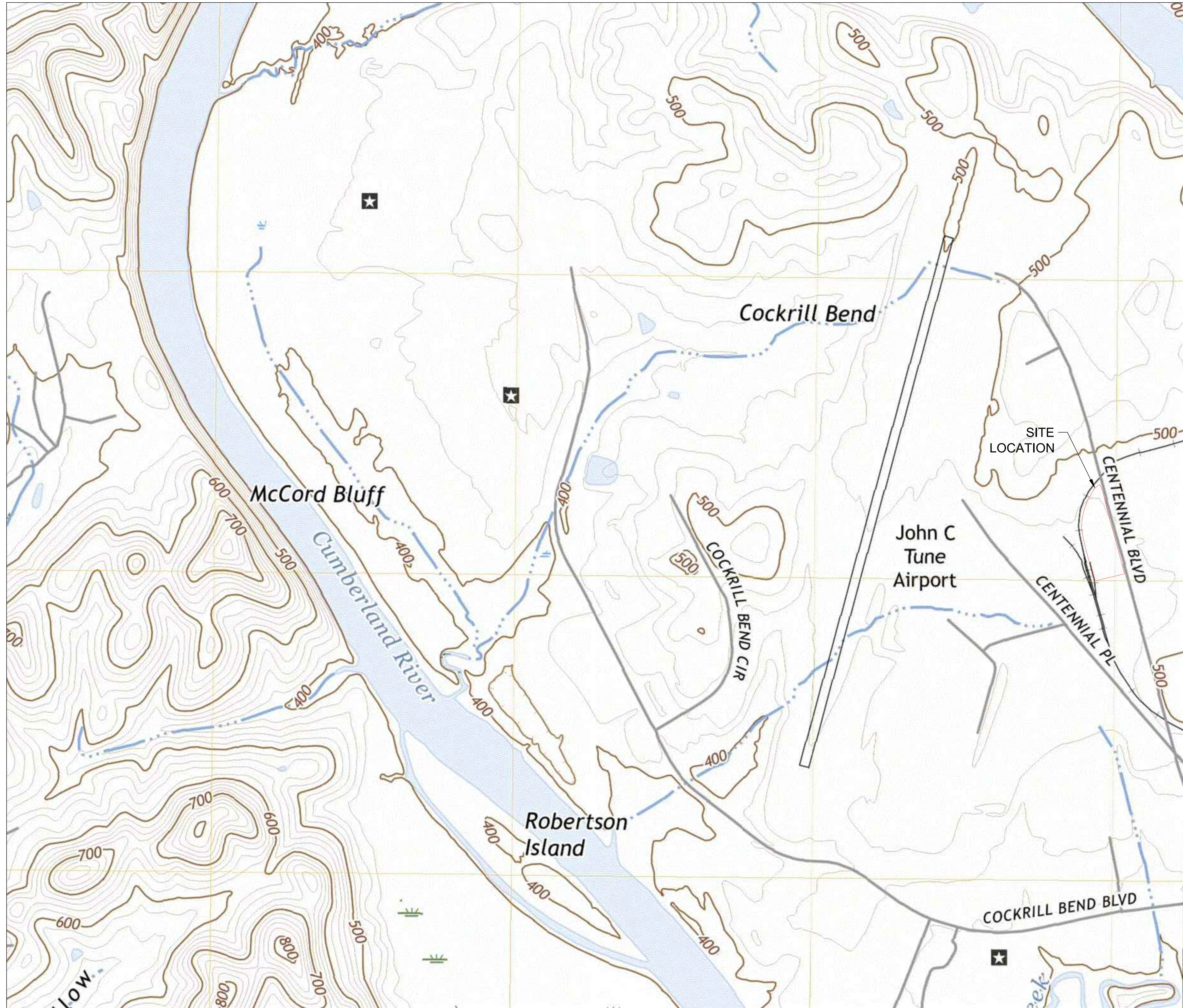

NOTES:

- 2022 SCOTTSBORO, TENNESSEE 7.5 MINUTE USGS QUADRANGLE MAPS, NORTH AMERICAN DATUM 1983 (NAD 83)

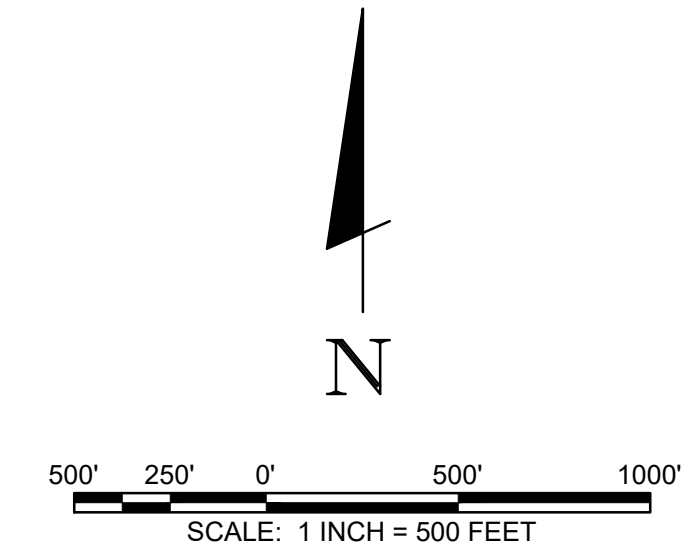

615 3rd Avenue South / Suite 700 / Nashville, Tennessee 37210
 PHONE (615) 254-1500 / FAX (615) 254-6572

PRELIMINARY
 NOT FOR
 CONSTRUCTION
 DATE _____

USGS QUADRANGLE MAP

TRIUNE CENTENNIAL PROCESSING FACILITY
 TRIUNE RESIDUALS MANAGEMENT, LLC
 7133 CENTENNIAL BLVD NASHVILLE, TN

REV.	DR.	CHK.	DATE	DESCRIPTION

EX

FILE NO. 3712202

APPENDIX 3 – Facility Layout

TRIUNE CENTENNIAL PROCESSING FACILITY

FOR THE

TRIUNE RESIDUALS MANAGEMENT, LLC

NASHVILLE, TN

CONTACTS

OWNER / DEVELOPER:
TRIUNE RESIDUALS MANAGEMENT, LLC
5800 ONE PERKINS PLACE, SUITE 6A
BATON ROUGE, LA 70808
CONTACT: SIDNEY BRIAN

CIVIL ENGINEER:
BARGE DESIGN SOLUTIONS
615 3RD AVENUE SOUTH, SUITE 700
NASHVILLE, TN 37210
CONTACT: JASON REPSHER

INDEX OF DRAWINGS

SHEET NO.	DESCRIPTION
C1	COVER SHEET
C2	FACILITY SITE PLAN
C3	SITE TRAFFIC FLOW
C4	SU-30 TURNING RADIUS
C5	WB-62 TURNING RADIUS
C6	DETAILS

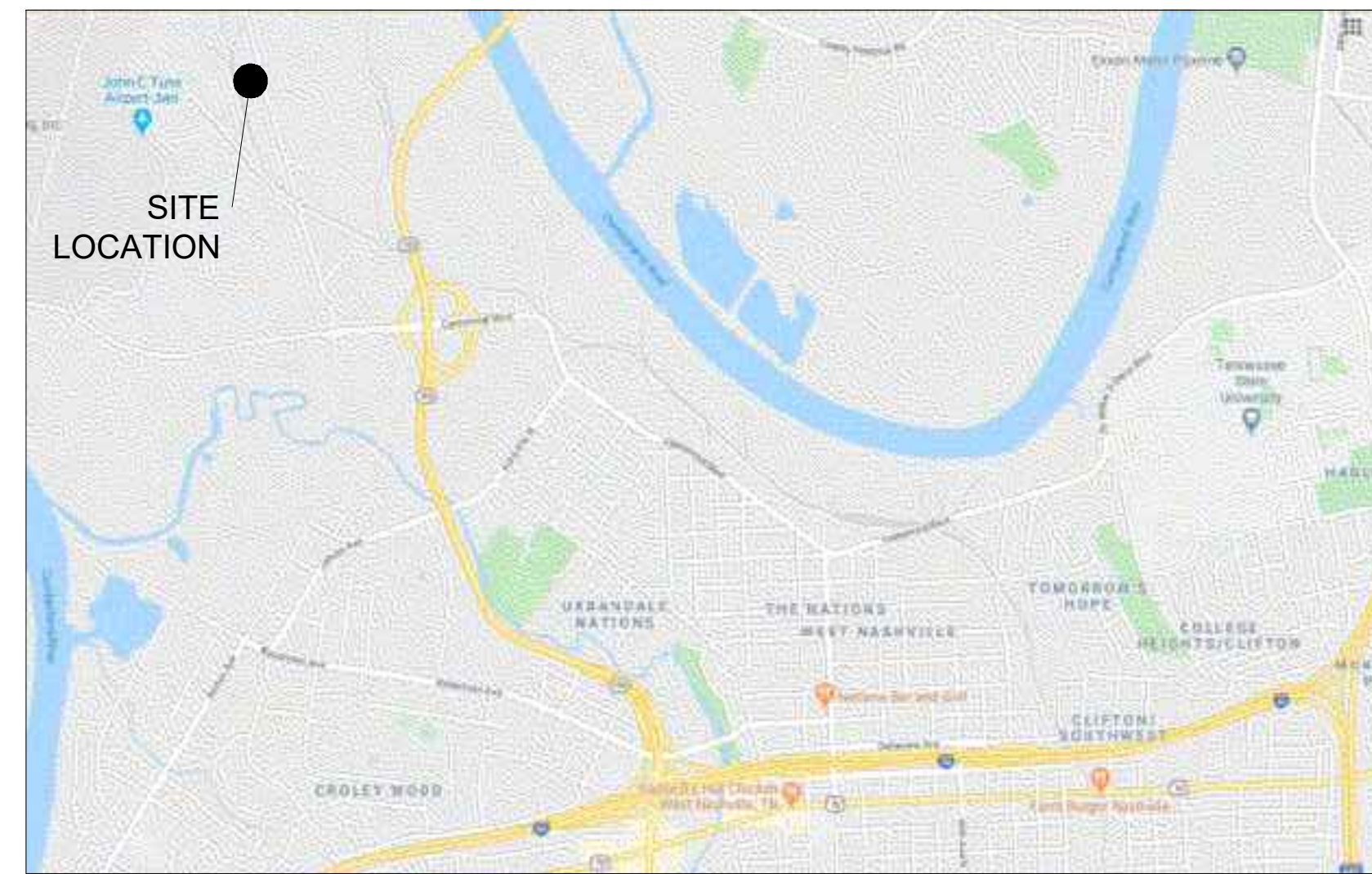

LOCATION MAP

NOT TO SCALE

PROJECT INFORMATION

PROJECT NAME	TRIUNE CENTENNIAL PROCESSING FACILITY
PARCEL ID NUMBER	07900011600
COUNCILMANIC DISTRICT	20TH DISTRICT
COUNCILMEMBER NAME	MARY CAROLYN ROBERTS
ADDRESS	7133 CENTENNIAL BLVD NASHVILLE, TN 37209

TRIUNE CENTENNIAL PROCESSING FACILITY
 FOR THE
TRIUNE RESIDUALS MANAGEMENT, LLC
 NASHVILLE, TN

NOTES:

- 1. PROPERTY BOUNDARIES ARE SHOWN FOR REFERENCE PURPOSES ONLY AND ARE BASED ON METRO PARCEL VIEWER.
- 2. AERIAL IMAGERY SHOWN IS FROM AN AERIAL SURVEY PERFORMED BY BARGE OCTOBER 2022. ENVIRONMENTAL SITE INVESTIGATION WAS PERFORMED BY BARGE IS NOVEMBER 2022.
- 3. ALL CONSTRUCTION AND DEMOLITION (C&D) WASTE PROCESSING, SORTING, SEPARATING, AND REDUCING WILL TAKE PLACE INSIDE OF THE EXISTING ENCLOSED BUILDING. SEE DETAIL 1, SHEET C6 FOR FACILITY LAYOUT. THE FACILITY IS CURRENTLY OPERATING UNDER A RMPF (RECOVERED MATERIALS PROCESSING FACILITY) DESIGNATION TO ACCEPT AND RECOVER MATERIALS SUCH AS CARDBOARD, GLASS, PLASTICS, SHINGLES, SCRAP TIRES, WOOD/GREEN WASTE, SCRAP METAL, AND METAL PRODUCTS FROM SEPARATED C&D WASTE.

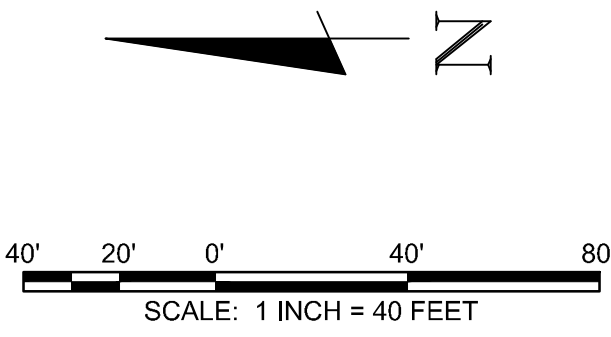

LEGEND

- PROPOSED**
- FACILITY BOUNDARY
- EXISTING**
- PROPERTY LINE
 - OVERHEAD POWER LINE
 - FENCE
 - STREAM
 - WETLAND

REVISION INFORMATION	
REV.	DESCRIPTION

USER: KBECKLER
 FILE: \\corp.bvcs.net\dataal\Projects\3737\220203_PROJECT_EXECUTION\06_PERMITS\Processing Facility_PBR\Jackson Law PBR Package\Appendices\Appendix 3 - Facility_Layout\Cad\EX - Facility_Layout.dwg
 SAVED: 11/9/2023
 PLOTTED: 11/9/2023

NOTES:

1. PROPERTY BOUNDARIES ARE SHOWN FOR REFERENCE PURPOSES ONLY AND ARE BASED ON METRO PARCEL VIEWER.
2. AERIAL IMAGERY SHOWN IS FROM AN AERIAL SURVEY PERFORMED BY BARGE OCTOBER 2022.

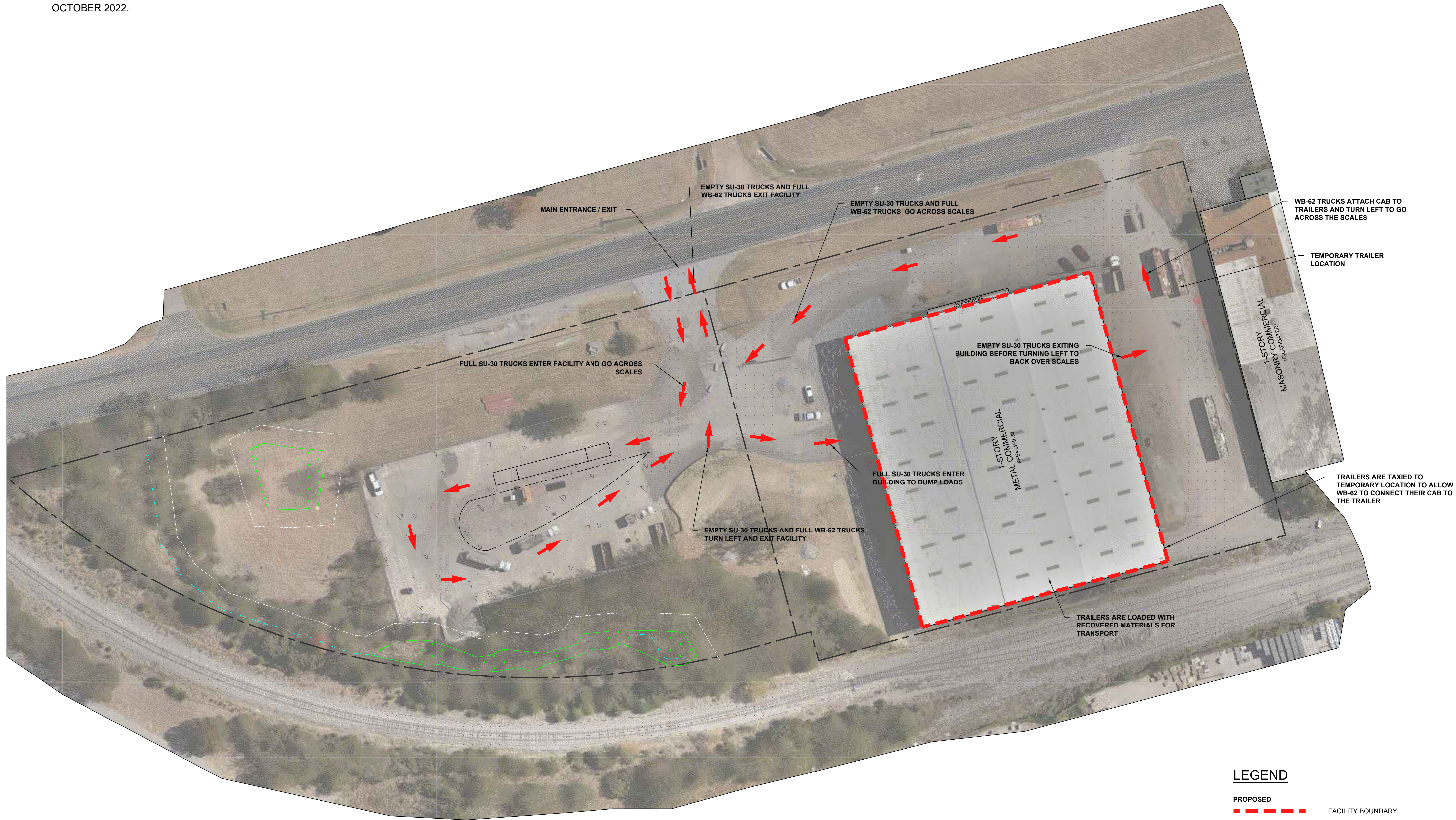

LEGEND

- PROPOSED**
- FACILITY BOUNDARY
- EXISTING**
- PROPERTY LINE
 - OVERHEAD POWER LINE
 - FENCE
 - STREAM
 - WETLAND

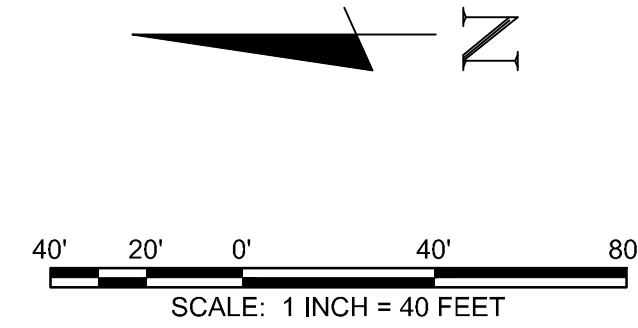

PRELIMINARY
NOT FOR
CONSTRUCTION

DATE

SITE TRAFFIC FLOW

TRIUNE CENTENNIAL PROCESSING FACILITY
TRIUNE RESIDUALS MANAGEMENT, LLC
7133 CENTENNIAL BLVD NASHVILLE, TN

REV.	DR.	CHK.	DATE	REVISION INFORMATION DESCRIPTION

NOTES:

1. PROPERTY BOUNDARIES ARE SHOWN FOR REFERENCE PURPOSES ONLY AND ARE BASED ON METRO PARCEL VIEWER.
2. AERIAL IMAGERY SHOWN IS FROM AN AERIAL SURVEY PERFORMED BY BARGE OCTOBER 2022.

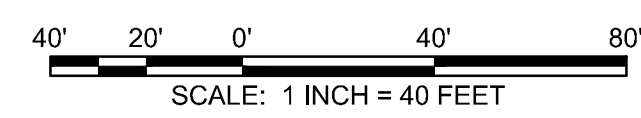
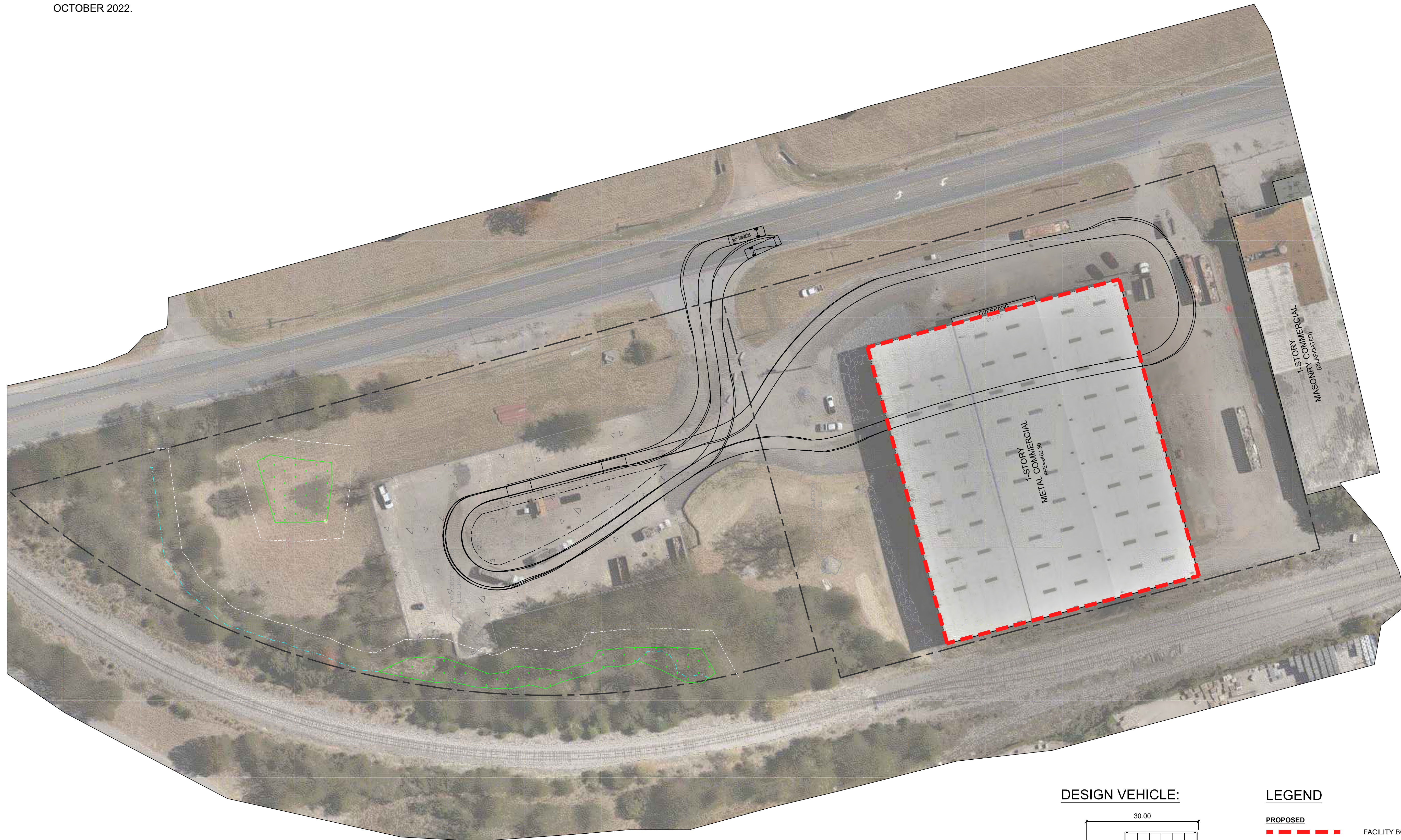

DESIGN VEHICLE:

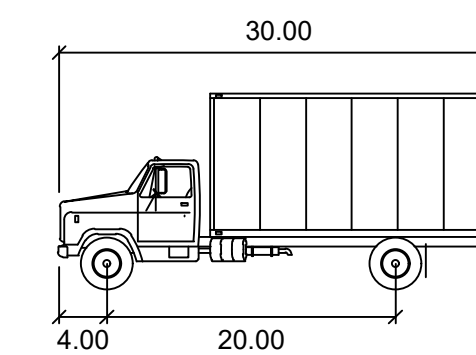

SU-30

Width	: 8.00
Track	: 8.00
Lock to Lock Time	: 6.0
Steering Angle	: 31.8

LEGEND

PROPOSED	
	FACILITY BOUNDARY
EXISTING	
	PROPERTY LINE
	OVERHEAD POWER LINE
	FENCE
	STREAM
	WETLAND

USER: KBECKLER
 FILE: \\corp.bvcs.net\data\Projects\37371220203_PROJECT_EXECUTION\06_PERMITS\Processing Facility_PBR\Jackson Law PBR Package\Appendices\Appendix 3 - Facility_Layout\Cad\EX - Facility_Layout.dwg
 SAVED: 11/9/2023
 PLOTTED: 11/9/2023

PRELIMINARY
NOT FOR
CONSTRUCTION

DATE

SU-30 TURNING RADIUS

TRIUNE CENTENNIAL PROCESSING FACILITY
TRIUNE RESIDUALS MANAGEMENT, LLC
 7133 CENTENNIAL BLVD NASHVILLE, TN

REVISION INFORMATION

NOTES:

1. PROPERTY BOUNDARIES ARE SHOWN FOR REFERENCE PURPOSES ONLY AND ARE BASED ON METRO PARCEL VIEWER.
2. AERIAL IMAGERY SHOWN IS FROM AN AERIAL SURVEY PERFORMED BY BARGE OCTOBER 2022.

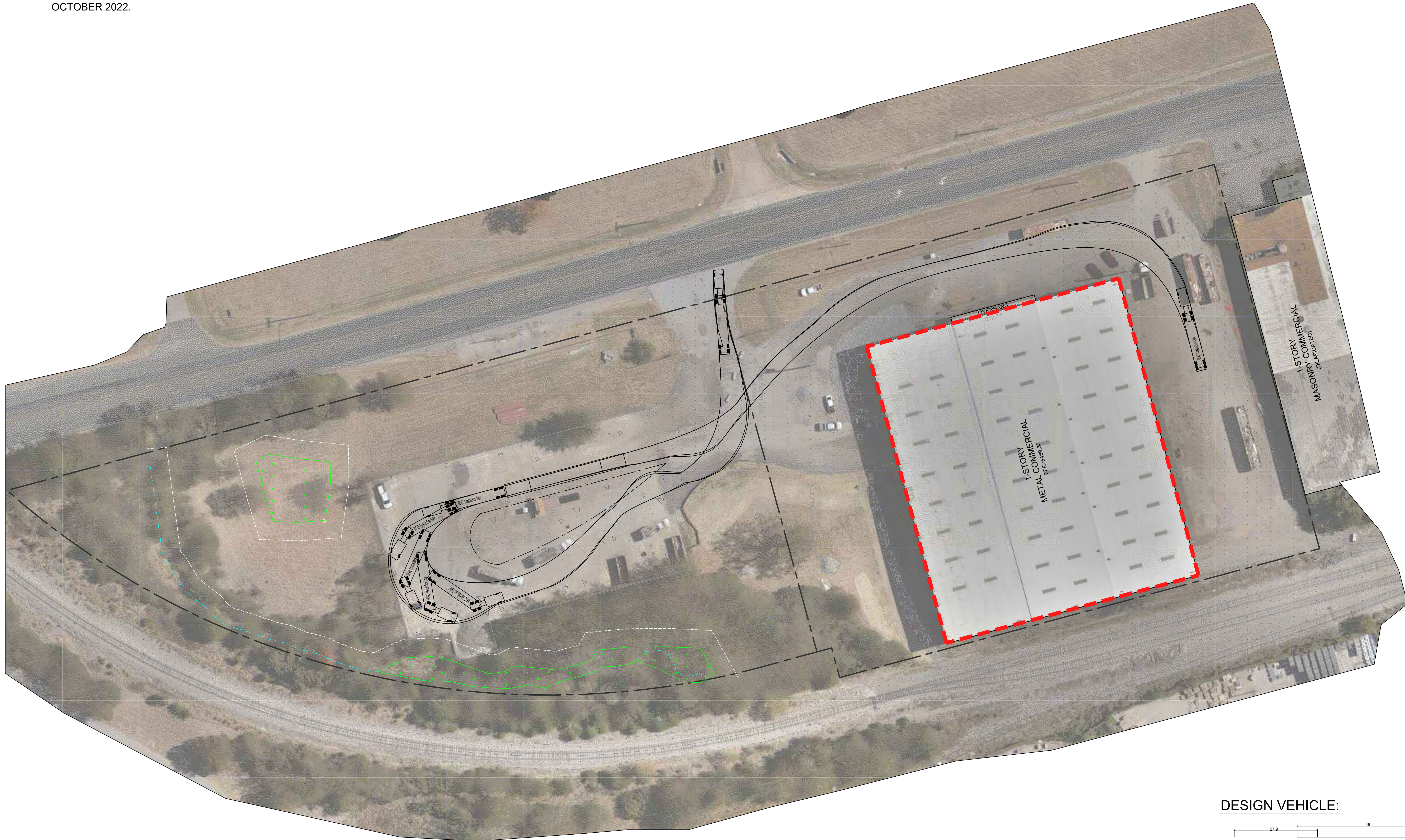

DESIGN VEHICLE:

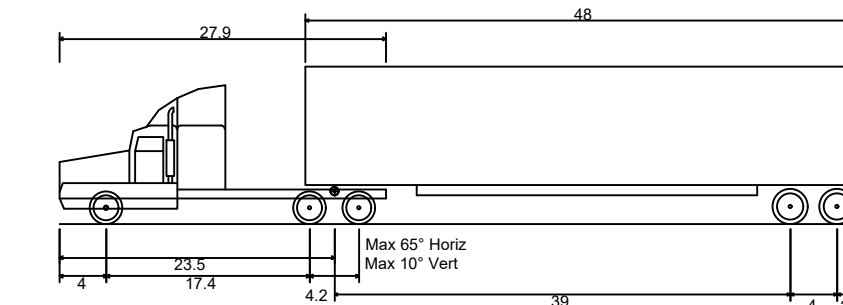

WB-62 - Interstate Semi-Trailer	69.00ft
Overall Length	8.50ft
Overall Width	13.50ft
Overall Body Height	1.334ft
Min Body Ground Clearance	8.50ft
Max Track Width	6.00s
Lock-to-lock time	44.80ft
Curb to Curb Turning Radius	

USER:KBECKLER
 FILE:\corp\hvac\data\Projects\37122023\PROJECT_EXECUTION\06_PERMITS\Processing Facility_PBR\Jackson Law PBR Package\Appendices\Appendix 3 - Facility_Layout\Cad\EX - Facility_Layout.dwg
 SAVED: 11/09/2023
 PLOTTED: 11/09/2023

PRELIMINARY
 NOT FOR
 CONSTRUCTION

DATE

WB-62 TURNING RADIUS

TRIUNE CENTENNIAL PROCESSING FACILITY
TRIUNE RESIDUALS MANAGEMENT, LLC
 7133 CENTENNIAL BLVD NASHVILLE, TN

REV.	DR.	CHK.	DATE	REVISION INFORMATION DESCRIPTION

C5

FILE NO. 3712202

**APPENDIX 4 –
Environmental Site Investigation**



STATE OF TENNESSEE
DEPARTMENT OF ENVIRONMENT AND CONSERVATION
DIVISION OF WATER RESOURCES

Nashville Environmental Field Office
711 R.S. Gass Boulevard
Nashville, TN 37216
Phone 615-687-7000 Statewide 1-888-891-8332 Fax 615-687-7078

November 29, 2022

Trinity Business Group, LLC
Sidney Brian
5800 One Perkins Pl. Ste. 6a
Baton Rouge, LA, 70808
sbrian@trinitybusinessgroup.net

Re: Hydrologic Determination (DWR ID No. 31788)
Centennial Boulevard, Nashville, Davidson County, Tennessee

Dear Landowner:

On November 21, 2022, the Division of Water Resources (division) received a jurisdictional waters report submitted on your behalf by Mr. Frank Amatucci with Barge Design Solutions. These water features are located on property located at: 36.182067, -86.878757 (Lat/Long), in Davidson County, Tennessee. Please note that all geographic coordinates provided in this letter have limited precision and should be considered approximate.

Please see the attached map and table for a summary of the jurisdictional determinations made by the division for the water features on site. These determinations are based on the information and documentation in the submitted report as well as the division's observations, rules, and guidance regarding hydrologic determinations.

Alterations to streams, wetlands, or other waters may only be performed under the coverage of, and conformance to, a valid *Aquatic Resource Alteration Permit (ARAP)* issued by the division, except where authorized by Rule. ARAP applications and provisions are available online at <http://www.tn.gov/environment/article/permit-water-aquatic-resource-alteration-permit>.

Any alterations to wet weather conveyances must be made in accordance with the requirements of Tenn. Code Ann. § 69-3-108(q).

Hydrologic determinations are advised and governed by Tennessee Department of Environment and Conservation (TDEC) rules and regulations, and therefore only apply to the State's permitting process. Because these and other various water features on-site may potentially also

November 29, 2022

Page 2 of 4

be considered jurisdictional Waters of the United States, any alterations to them should only be performed after consultation with the U.S. Army Corps of Engineers.

Discharges and alterations to sinkholes may require the submittal of an application and written authorization under the provisions of TDEC Rules. You may contact Mr. Brian Ham at (615) 532- 9224 to help identify permit requirements related to sinkhole alterations.

If the disturbed area of this project is one acre or greater, coverage under the *General NPDES Permit for Stormwater Discharges from Construction Activities (CGP)* will be required from this division before any clearing or earth-moving activities are started. Information on the construction stormwater permit is available online at

<http://www.tn.gov/environment/article/permit-water-npdes-stormwater-construction-permit>.

I appreciate the opportunity to assess the water features on-site prior to site plan finalization and initiation of construction activities. Because natural variation and human activities can alter hydrologic conditions, the division reserves the right to reassess the status of the water features in the future.

Thank you for your interest in water quality in Tennessee. If you have any questions or need additional information, please contact me at 629-666-0521 or by email at Clayton.Mahan@tn.gov.

Sincerely,

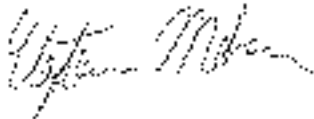

Division of Water Resources

cc:

U.S. Army Corp of Engineers, NashvilleRegulatory@usace.army.mil

Michael Hunt, MS4 Program Manager, michael.hunt@nashville.gov

Frank Amatucci, Barge, frank.amatucci@bargedesign.com

Feature	Classification	Starting Lat/Long	Ending Lat/Long
STR-1	Stream	36.183269, -86.878227	36.182013, -86.878801
SWD-1	Wet Weather Conveyance	36.181543, -86.877803	36.181507, -86.878744
WTL-1	Wetland	36.182067, -86.878757	-
WTL-2	Wetland	36.182911, -86.878281	-

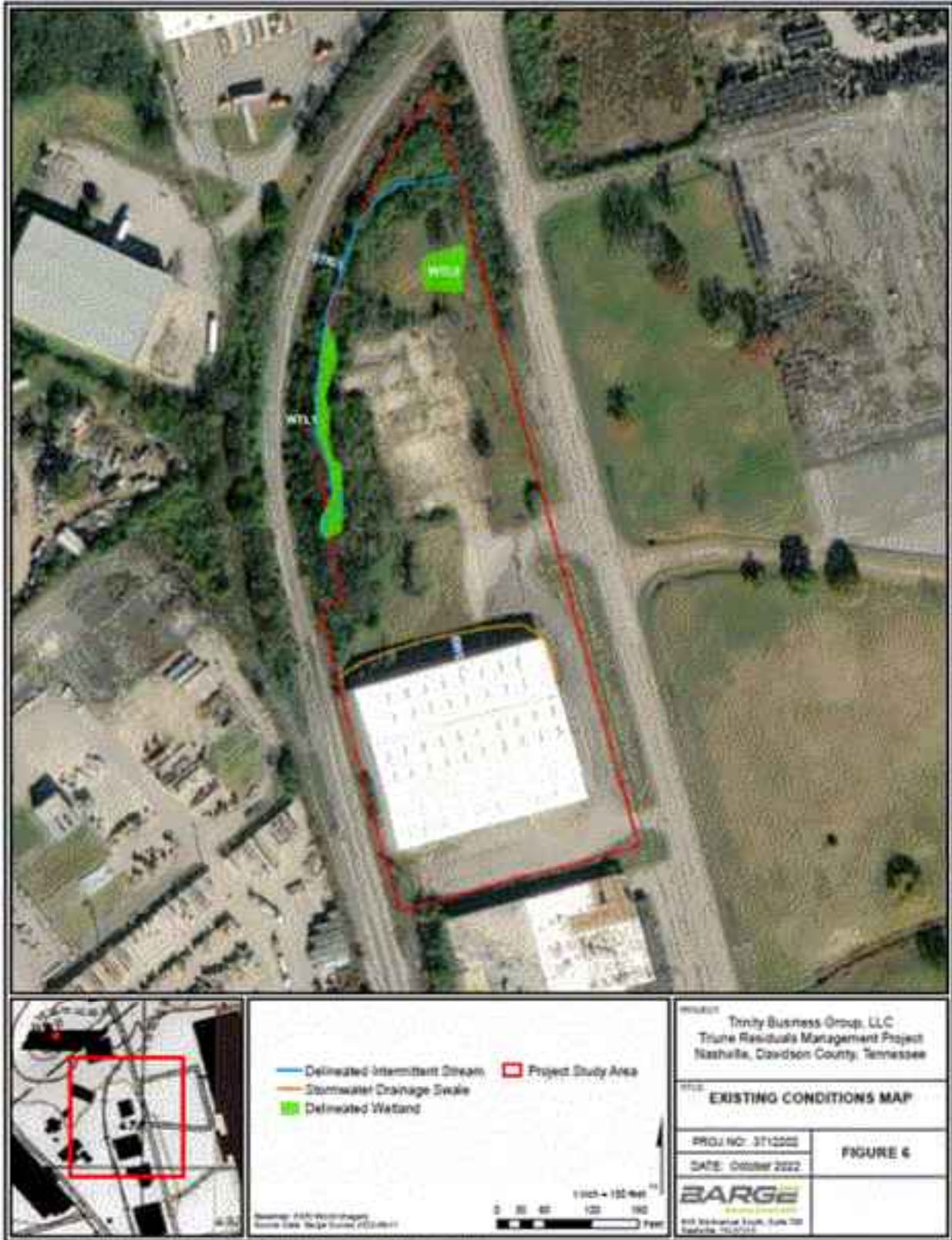



TRIUNE RESIDUALS MANAGEMENT PROJECT

HYDROLOGIC DETERMINATION REQUEST PACKAGE

Prepared For: Trinity Business Group

Sent To: TDEC Division of Water Resources
Nashville Environmental Field Office
711 R.S. Gass Blvd,
Nashville, TN 37216

3712202
November 2022

CONTENTS

EXECUTIVE SUMMARY	1
1.0 INTRODUCTION.....	2
1.1 Study Area.....	2
2.0 ENVIRONMENTAL REVIEW.....	2
2.1 Field Investigation Methodology.....	3
2.1.1 Waterbody Identification	3
2.1.2 Wetland Boundary Identification.....	3
3.0 RESULTS.....	3
3.1 Non-Wetland Waters.....	4
3.2 Wetlands.....	4
4.0 SUMMARY.....	5

APPENDICES

APPENDIX A – TDEC ACCESS AUTHORIZATION LETTER

APPENDIX B - FIGURES

APPENDIX C – NON-WETLAND FEATURES AND WETLANDS TABLES

APPENDIX D - STREAM AND WETLAND DETERMINATION DATA FORMS

APPENDIX E - PHOTOGRAPHIC SUMMARY

EXECUTIVE SUMMARY

Barge Design Solutions, Inc. (Barge) has been retained to identify natural resources on a property that is approximately 5.5 acres (project study area) for a proposed commercial development as part of a local waste services facility, located in Nashville, Davidson County, Tennessee. The project study area is located at 7211 Centennial Boulevard, west of the Carlisle automotive glass manufacturing facility in the Cockrill Bend commercial district of Nashville. The project study area includes parcel Number. 07900000401.

Barge is submitting the attached Hydrologic Determination (HD) Package for concurrence with observed features within the project study area. The hydrologic determinations performed for the project were conducted by Frank Amatucci (TN-QHP #1203-TN21). In total, three potentially jurisdictional and one non-jurisdictional features were identified within the project study area, all of which were considered as wetlands, intermittent stream, and a stormwater drainage swale. These jurisdictional and non-jurisdictional resource features were identified during the field investigation of the project study area. The delineated resource features are described in this HD Package, as well as the methodologies utilized to determine each feature's jurisdictional status and the figures and tables that represent the length, acreage, and location within the project study area.

Property Owner Requesting HD

Trinity Business Group, LLC
Sidney Brian
5800 One Perkins Pl. Ste. 6A
Baton Rouge, LA, 70808
Phone: 225-766-1443
Email: sbrian@trinitybusinessgroup.net

1.0 INTRODUCTION

The purpose of the environmental assessment was to determine the extent of potential onsite jurisdictional wetlands and non-wetland waters pursuant to the state and federal rules and regulations. The information provided in the attached HD Package characterizes the existing wetlands, streams, and other non-wetland waters that may be used in an effort to avoid or minimize impacts to identified resources.

1.1 Study Area

The project study area was historically utilized for as an industrial warehouse and affiliated truck parking, especially within the southern half within parcel No. 07900000401. The remaining norther area was observed as fragmented woodland and open fallow field. The wooded portions of the project study area ranged between scrub/shrubland and early successional urban forest. A Project Location Map depicting the area can be found in Appendix B, Figure 1. Other surrounding properties are primarily commercial.

The project study area is located approximately 0.4 miles north of the intersection of Centennial Place and Centennial Boulevard in Nashville, Davidson County, Tennessee (Appendix B, Figure 1). This area falls within the Interior Plateau (71) Tennessee ecoregion and is further categorized into the Outer Nashville Basin (71h) physiographic region of Tennessee. The project study area is within the Scottsboro, Tennessee, topographic quadrangle (Appendix B, Figure 2), and the property is located within the Indian Creek-Cumberland River (051302020306) lower HUC-12 watershed, which is located within the Lower Cumberland-Sycamore HUC-8 watershed (05130202), which is ultimately within the Cumberland River Basin (Appendix B, Figure 3).

2.0 ENVIRONMENTAL REVIEW

Prior to visiting the project study area, a resource review of available background site information was conducted using the U.S. Fish and Wildlife Service's (USFWS) National Wetland Inventory (NWI) database to determine if wetlands could be found within the area. Topographic maps and the United States Geological Survey (USGS) National Hydrography Dataset (NHD) were evaluated for potential jurisdictional waters, and the United States Department of Agriculture (USDA) Natural Resources Conservation Service's (NRCS) Web Soil Survey was reviewed for potential of hydric soils. Additionally, major landscapes and vegetation units were identified using aerial imagery prior to surveying the study area and again in the field before beginning field work.

2.1 Field Investigation Methodology

2.1.1 Waterbody Identification

For the purpose of this report, any ephemeral or more persistent drainages were characterized by the presence of two or more Ordinary High-Water Mark (OHWM) indicators using the 2005 *U.S. Army Corps of Engineers (USACE) Regulatory Guidance Letter 05-05* and proximity to other adjoining jurisdictional features (i.e., wetlands and/or intermittent or perennial streams). Streams located within the project study area were verified, and coordinates of the centerline were obtained with a GPS unit.

Additionally, waterbodies were analyzed with the Tennessee Department of Environment and Conservation's (TDEC) "Guidance for Making Hydrologic Determinations" to accurately determine the jurisdictional status of Waters of the State. Hydrologic determinations (HD) were conducted by Frank Amatucci (TN-QHP #1203-TN21). The TDEC HD Field Data Sheets for all observed streams and wet weather conveyances are provided in Appendix D.

2.1.2 Wetland Boundary Identification

Wetland determinations were conducted by Barge biologists through observing hydrophytic vegetation, hydric soils, and wetland hydrology according to the USACE *Regional Supplement to the Corps of Engineers Wetland Delineation Manual: Eastern Mountains and Piedmont Region, Version 2.0*. Sample points were chosen based upon representative portions of the study area to confirm visual estimates of field indicators. The Eastern Mountains and Piedmont Regional Wetland Determination Data Forms were completed at wetland and upland sample points (Appendix D). The boundaries of the wetlands were then marked in the field with pink flagging, and coordinates were obtained with a GPS unit.

3.0 RESULTS

On August 11, 2022, Barge biologist performed a field survey within the project study area to determine the presence or absence of jurisdictional waters. Both the USACE and TDEC methodologies were utilized to determine the jurisdiction of wetlands and non-wetland waters within the project study area.

In total, three potentially jurisdictional and one non-jurisdictional features were identified within the project study area, all of which were considered as wetlands, intermittent stream, and a stormwater drainage swale. The sections below detail the features that were delineated within the project study area. The features identified on site are listed in Table 1 and Table 2 (Appendix C) and are displayed in Figure 6 (Appendix B).

3.1 Non-Wetland Waters

Barge biologist Frank Amatucci (TN-QHP #1203-TN21) conducted the Hydrologic Determination (HD) site investigation in accordance with TDEC Rule 0400-40-17-.04. In addition, water features were considered regarding the Regulatory Guidance Letter No. 05-05 for ephemeral streams. The site visit was conducted more than 48 hours following a significant rain event of greater than 1.0 inch in a 24-hour period. Upon commencement of the study, 0.83 inches of precipitation was observed in the preceding 7 days (CoCoRaHS STA# TN-DV-138). In the preceding 30 days, 2.04 inches of rain were observed. The precipitation for the preceding three months is considered “wetter than normal” based on the 30-year normal (Appendix D).

One intermittent stream (STR) and one stormwater drainage swale (SWD) were delineated within the project study area. These features were based current site conditions and secondary indicators while conducting the HD. Below are brief descriptions of the delineated waterbody features within the project study area. Figure 6 -- Existing Conditions Map (Appendix B) illustrates the locations of the streams and man-made drainage swale within the project study area, and Table 1 (Appendix C) details the locations and lengths of each feature. Furthermore, photographs of each feature are provided in Appendix E, and the HD data form is provided in Appendix D.

STR-1 was observed as an intermittent stream along the northern and western limits of the project study area. The delineated stream was observed with a moderate presence of baseflow, which traversed to the southwest into wetland (WTL) WTL-1, where the defined channel of the stream continues offsite to the southwest. Bed and bank upslope of WTL-1 is moderately present throughout the inspected reach, as well as Ordinary High-Water Mark (OHWM) indicators. STR-1 had as channel bottom composed of bedrock, cobble, and sand. STR-1 is assumed to be jurisdictional to TDEC and the USACE.

SWD-1 was observed as a man-made drainage swale north of the existing warehouse structure within the project study area. The man-made drainage swale originates from a stormwater grate at the entrance of the building and is conveyed to the west along the northside of the warehouse to the offsite downstream portion of STR-1. SWD-1 was observed with no visible indication of channel formation and was entirely rip-rapped within the project study area. SWD-1 is assumed to be non-jurisdictional to TDEC as a wet weather conveyance and to the USACE.

3.2 Wetlands

Two wetlands (WTL) were observed within the project study area. The delineated wetlands were observed as Palustrine Emergent (PEM) and Palustrine Forested (PFO) wetland features. Each wetland was verified with the positive identification of suitable hydrology, hydrophytic vegetation, and hydric soils. Below are brief descriptions of the delineated wetland features within the project study area. The locations of the delineated wetlands are provided in Figure 6 -- Existing Conditions Map (Appendix B), and Table 2 (Appendix C) details the location and acreage of each

wetland. A photograph of each wetland feature is provided in Appendix E, and the wetland determination data forms are provided in Appendix D.

WTL-1 was observed as a floodplain PFO wetland along the stream valley of STR-1 in the western portion of the project study area. The floodplain wetland is situated at the downslope portion of STR-1, where bed and bank begin to weaken. All excess surface water drains back into STR-1 at the western limit of the project study area and potential other Waters of the United States (WOTUS). WTL-1 was observed with a presence of saturation, a perched water table, and water-stained leaves, indicating positive wetland hydrology. The wetland was observed with a dominance of hydrophytic vegetation such as green ash (*Fraxinus pensylvanica*) in the tree and sapling stratum; and fowl mannagrass (*Glyceria striata*) and clear wed (*Pilea pumila*) in the herbaceous stratum. Hydric soils were also documented in WTL-1, which were observed with a shallow dark layer underlain by depleted hydric soils with a presence of redoximorphic concentrations. Due to the potential connection to other WOTUS, WTL-1 is assumed to be jurisdictional to TDEC and the USACE.

WTL-2 was observed as a PEM depressional wetland in the northern portion of the project study area. The wetland is likely a man-made depressional feature on top of shallow bedrock. No observable outfall, inlet, or surface water connection to other water resources was determined. Therefore, WTL-2 was determined to be isolated from other WOTUS. WTL-2 was observed with a presence of saturation and water-stained leaves, indicating positive wetland hydrology. The wetland was observed with a dominance of hydrophytic vegetation such as fox sedge (*Carex vulpinoidea*), nut sedge (*Cyperus esculentus*), and pepper weed (*Persicaria hydropiper*) in the herbaceous stratum. Shallow hydric soils were also documented in WTL-2, which were observed with a thin dark layer underlain by depleted hydric soils on top of shallow bedrock. Due to the lack of observable connection to other WOTUS, WTL-2 is assumed to be isolated and non-jurisdictional to the USACE and only jurisdictional to TDEC.

4.0 SUMMARY

Two wetlands, one intermittent stream, and one man-made stormwater drainage swale were identified during the field investigation of the project study area. The Existing Conditions Map (Figure 6, Appendix B) visually represents the boundaries of the wetlands and non-wetland waters delineated within the project area. Table 1 and Table 2 (Appendix C) also summarize the current locations and linear footages or acres of each feature, and the determination data forms for the delineated resources are provided in Appendix D.

APPENDIX A – TDEC ACCESS AUTHORIZATION LETTER

October 18, 2022

Tennessee Department of Environment and Conservation
Nashville EPC
713 R.S. Goss Blvd.
Nashville, Tennessee 37216

RE: Access Authorization for Trilune Residuals Management Project Site

To whom it may concern:

Trilune Business Group, LLC is seeking to identify and locate natural resource features within the project study area for a proposed commercial development as part of a local waste services facility, located in Nashville, Davidson County, Tennessee. The project study area is located at 7211 Centennial Boulevard, west of the Carisle automotive glass manufacturing facility in the Cocke's Bend commercial district of Nashville. The project study area includes parcel number: 0750000001.

In order to allow all required review of the property, we hereby allow access to the Tennessee Department of Environment and Conservation on the subject property for required site visits.

If you have any questions or require additional information, please do not hesitate to contact me at (225)-768-1443 or sbrian@trilunebusinessgroup.net

Thank you,



Sid Brian

Attachments

C: Frank Amalucci, Barge
Jason Ropshar, Barge
Charrel Wright, Barge

APPENDIX B - FIGURES

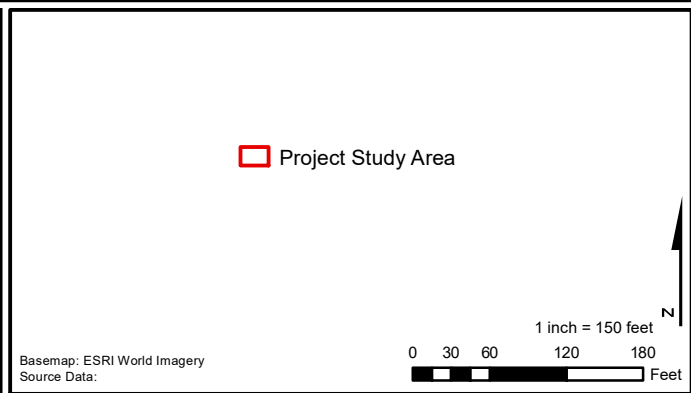
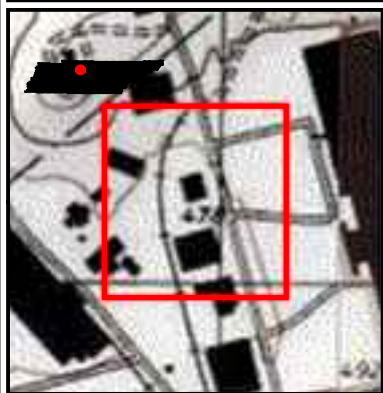

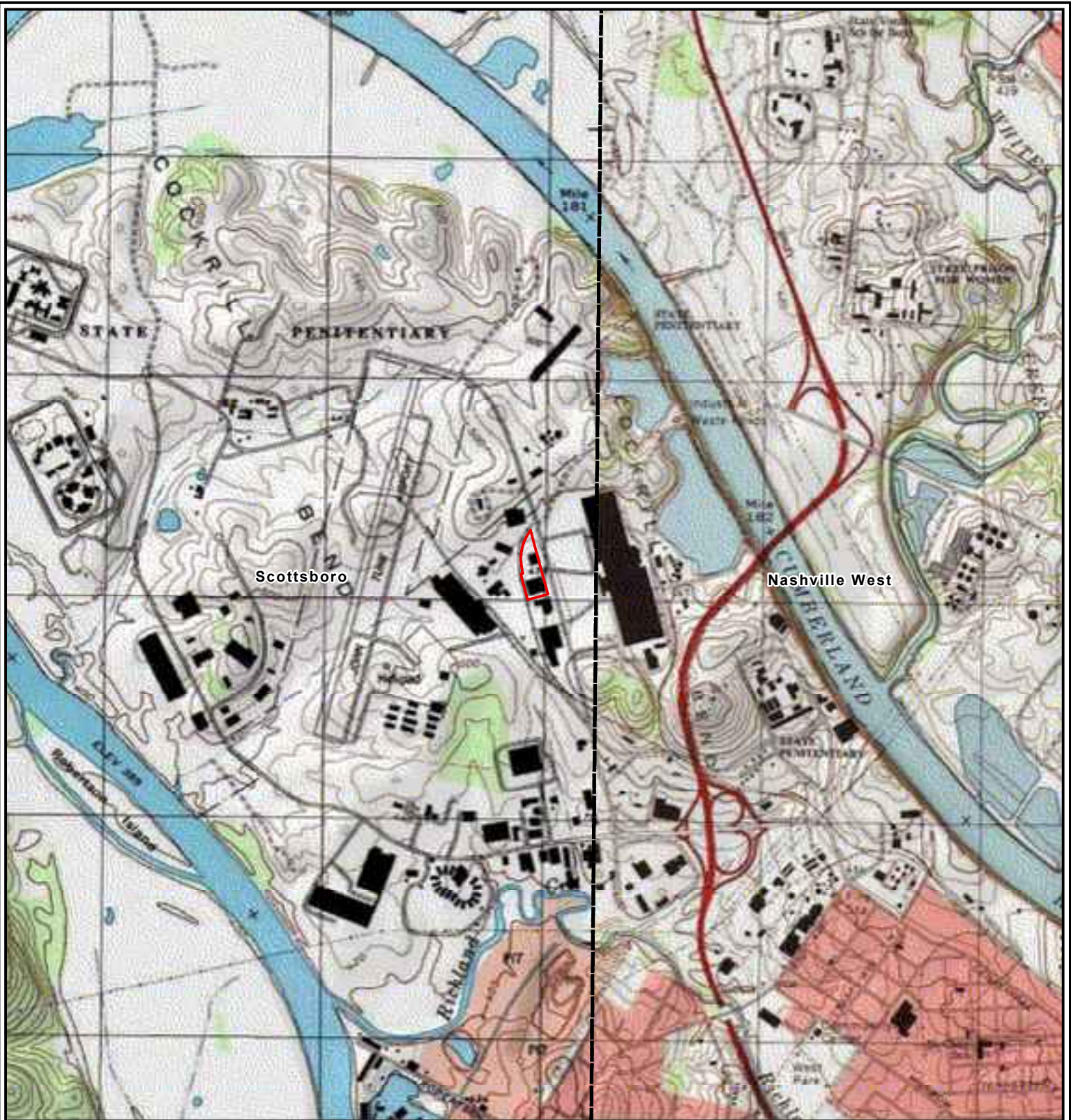

PROJECT: Trinity Business Group, LLC Triune Residuals Management Project Nashville, Davidson County, Tennessee	
TITLE: AERIAL SITE LOCATION MAP	
PROJ NO: 3712202	FIGURE 1
DATE: October 2022	
615 3rd Avenue South, Suite 700 Nashville, TN 37210	



SCOTTSBORO 7.5 MINUTE QUADRANGLE



-  Project Study Area
-  USGS 24k Topo Map Boundary

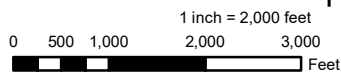

Basemap: ESRI USA Topo Map
Source Data: ESRI 24K Boundaries

PROJECT: Trinity Business Group, LLC
Triune Residuals Management Project
Nashville, Davidson County, Tennessee

TITLE: **USGS SITE LOCATION MAP**

PROJ NO: 3712202

FIGURE 2

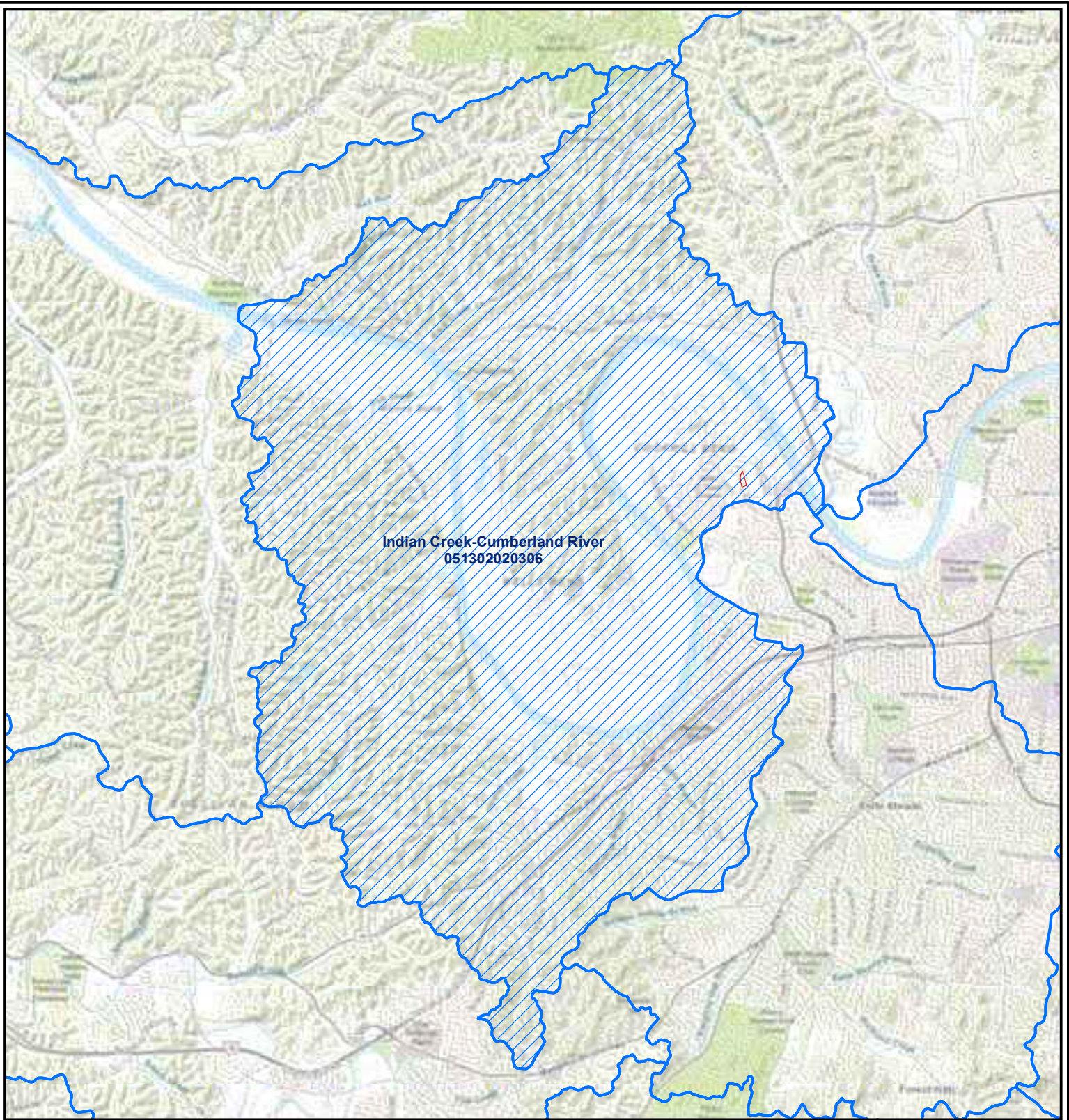

DATE: October 2022

BARGE
615 3rd Avenue South, Suite 700
Nashville, TN 37210



Indian Creek-Cumberland River
051302020306



-  Project Watershed
-  HUC 12 Watershed
-  Project Study Area

PROJECT:
Trinity Business Group, LLC
Triune Residuals Management Project
Nashville, Davidson County, Tennessee

TITLE:
PROJECT WATERSHED MAP

PROJ NO: 3712202

FIGURE 3

DATE: October 2022

BARGE
615 3rd Avenue South, Suite 700
Nashville, TN 37210

1 inch = 2 miles



Basemap: ESRI USA Topo Map
Source Data: ESRI 24K Boundaries

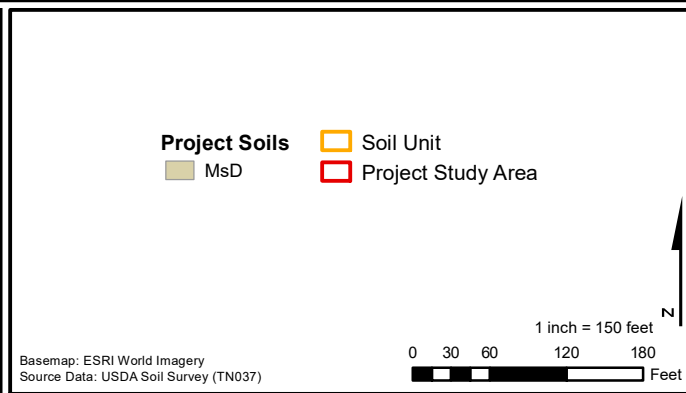
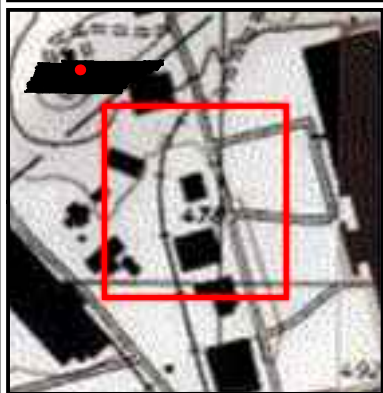

PROJECT: Trinity Business Group, LLC Triune Residuals Management Project Nashville, Davidson County, Tennessee	
TITLE: PROJECT SOIL UNIT MAP	
PROJ NO: 3712202	FIGURE 4
DATE: October 2022	
 615 3rd Avenue South, Suite 700 Nashville, TN 37210	

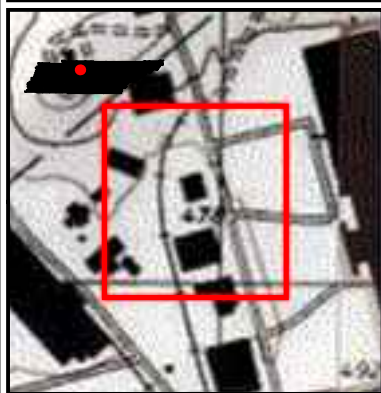

NWI Wetland

Wetland Type

- Freshwater Emergent Wetland
- Freshwater Forested/Shrub Wetland
- Freshwater Pond
- Lake
- Riverine

Project Study Area

Basemap: ESRI World Imagery
 Source Data: USFWS NWI (TN); USGS NHD Flowline (TN)

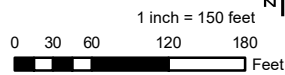

PROJECT:

Trinity Business Group, LLC
 Triune Residuals Management Project
 Nashville, Davidson County, Tennessee

TITLE:

**NATIONAL WETLAND
 INVENTORY MAP**

PROJ NO: 3712202

FIGURE 5

DATE: October 2022

BARGE
WETLAND CONSULTANTS
 615 3rd Avenue South, Suite 700
 Nashville, TN 37210

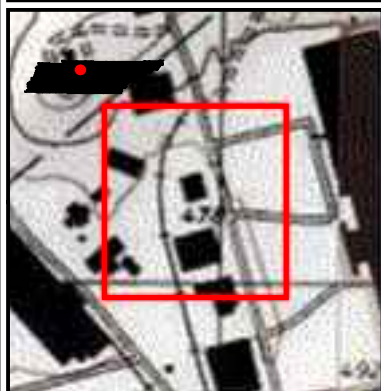
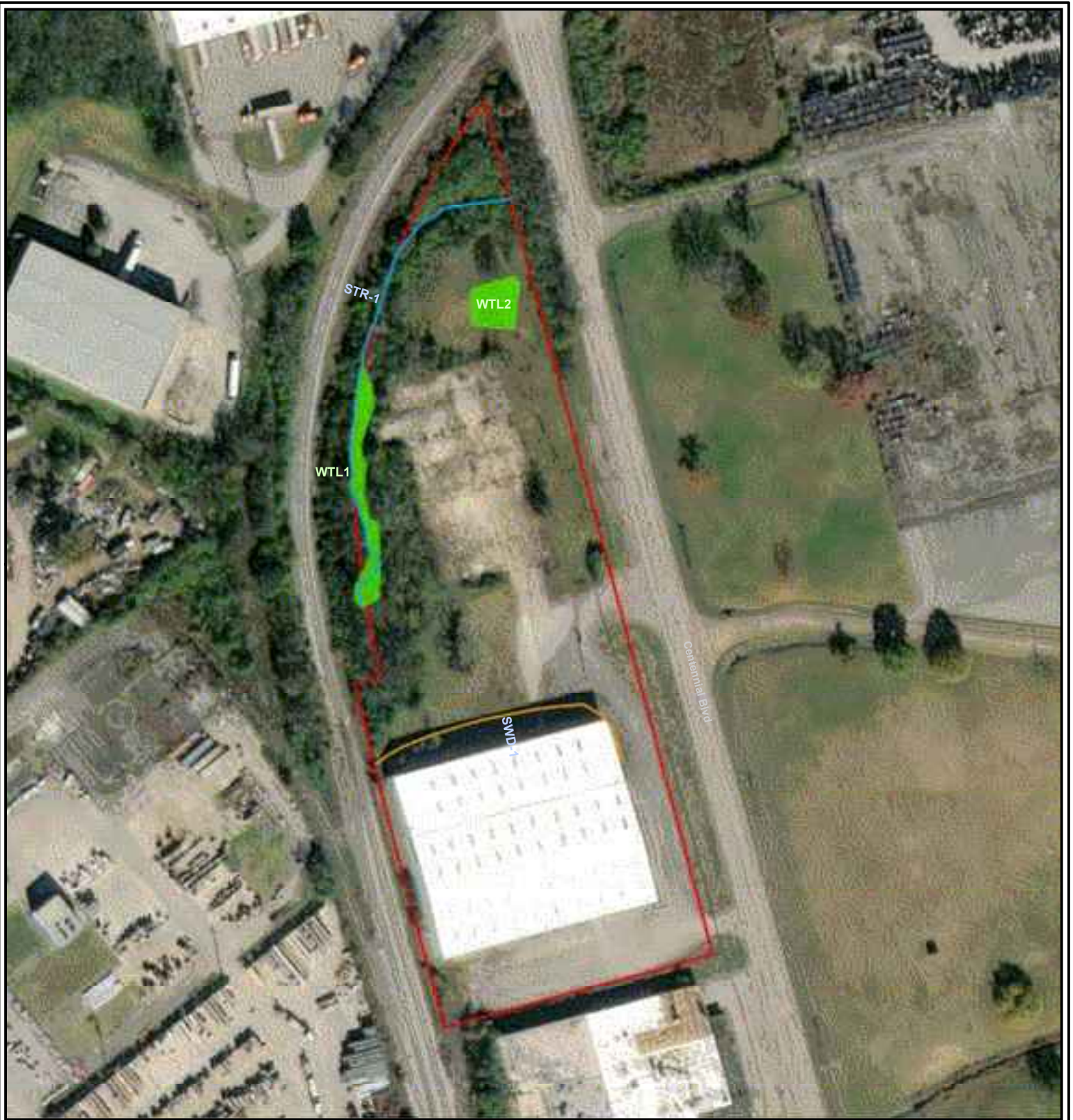

- Delineated Intermittent Stream
- Stormwater Drainage Swale
- Delineated Wetland
- Project Study Area

Basemap: ESRI World Imagery
 Source Data: Barge Survey 2022-08-11

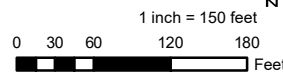

PROJECT:
 Trinity Business Group, LLC
 Triune Residuals Management Project
 Nashville, Davidson County, Tennessee

TITLE: **EXISTING CONDITIONS MAP**

PROJ NO: 3712202

FIGURE 6

DATE: October 2022

BARGE
WETLAND CONSULTING
 615 3rd Avenue South, Suite 700
 Nashville, TN 37210

APPENDIX C – NON-WETLAND FEATURES AND WETLANDS TABLES

Table 1 – Non-Wetland Features within the Project study area

Waterbody I.D.	Description	Location Within Project Boundaries	Linear Feet within Project	HD Score	Federal Jurisdictional Status	State Jurisdictional Status
STR-1	Intermittent Stream	Start: 36.183269, -86.878227 End: 36.182013, -86.878801	571	22.0	Yes	Yes
SWD-1	Stormwater Drainage Swale	Start: 36.181543, -86.877803 End: 36.181507, -86.878744	323	--	No	No

1: Federal jurisdiction status determined by observable connection to RPW and NonRPW WOTUS or significant nexus

Table 2 – Wetlands within the Project study area

Waterbody I.D.	Description	Location Within Project Boundaries	Acreage within Project	Federal Jurisdictional Status	State Jurisdictional Status
WTL-1	PFO	36.182067, -86.878757	0.10	Yes ¹	Yes
WTL-2	PEM	36.182911, -86.878281	0.06	No ¹	Yes

1: Federal jurisdiction status determined by observable connection to RPW and NonRPW WOTUS or significant nexus

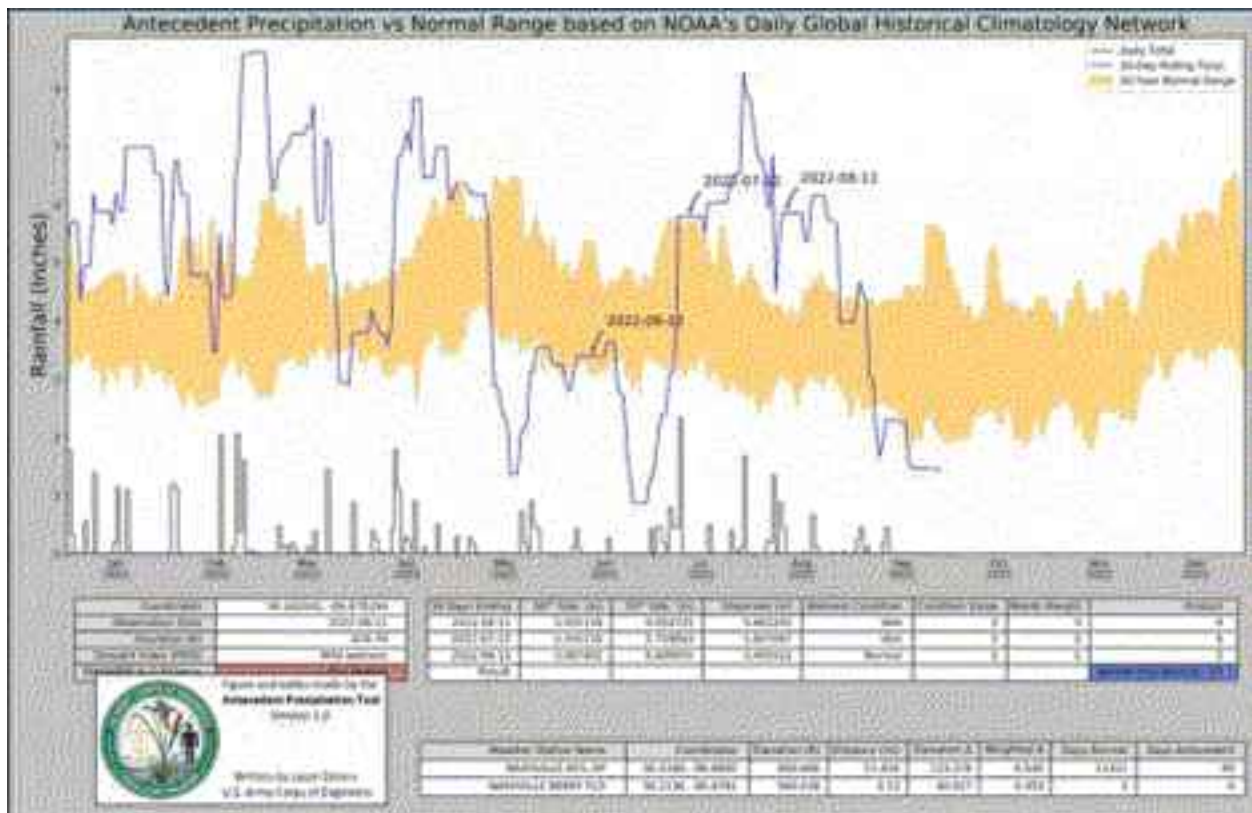

APPENDIX D - STREAM AND WETLAND DETERMINATION DATA FORMS

Hydrologic Determination Field Data Sheet

Tennessee Division of Water Pollution Control, Version 1.5

Named Waterbody: STR-1		Date/Time: 08/11/22 09:30
Assessors/Affiliation: F. Amatucci (TN-QHP #1203-TN21)		Project ID : 3712202
Site Name/Description: TBG 7211 Centennial Blvd Site		
Site Location: Nashville, Davidson County, Tennessee		
HUC (12 digit): Indian Creek-Cumberland River (051302020306)		Lat/Long: Start: 36.183269, -86.878227 End: 36.182013, -86.878801
Previous Rainfall (7-days) : 0.83 inches (CoCoRaHS STA# TN-DV-138)		
Precipitation this Season vs. Normal : abnormally wet <input type="checkbox"/> elevated <input checked="" type="checkbox"/> average <input type="checkbox"/> low <input type="checkbox"/> abnormally dry <input type="checkbox"/> unknown <input type="checkbox"/> Source of recent & seasonal precip data : <input type="checkbox"/> <input checked="" type="checkbox"/> <input type="checkbox"/> <input type="checkbox"/> <input type="checkbox"/> <input type="checkbox"/>		
Watershed Size : 0.10 sqmi (StreamStats)	County: Davidson	
Soil Type(s) / Geology : MsD	Source: NRCS	
Surrounding Land Use : Commercial, fragmented woodland, industrial		
Degree of historical alteration to natural channel morphology & hydrology (circle one & describe fully in Notes) : Severe <input type="checkbox"/> Moderate <input checked="" type="checkbox"/> Slight <input type="checkbox"/> Absent <input type="checkbox"/>		

Primary Field Indicators Observed

Primary Indicators	NO	YES
1. Hydrologic feature exists solely due to a process discharge	<input checked="" type="checkbox"/>	WWC <input type="checkbox"/>
2. Defined bed and bank absent, vegetation composed of upland and FACU species	<input checked="" type="checkbox"/>	WWC <input type="checkbox"/>
3. Watercourse dry anytime during February through April 15th, under normal precipitation / groundwater conditions	<input checked="" type="checkbox"/>	WWC <input type="checkbox"/>
4. Daily flow and precipitation records showing feature only flows in direct response to rainfall	<input checked="" type="checkbox"/>	WWC <input type="checkbox"/>
5. Presence of multiple populations of obligate lotic organisms with ≥ 2 month aquatic phase	<input checked="" type="checkbox"/>	Stream <input type="checkbox"/>
6. Presence of fish (except <i>Gambusia</i>)	<input checked="" type="checkbox"/>	Stream <input type="checkbox"/>
7. Presence of naturally occurring ground water table connection	<input checked="" type="checkbox"/>	Stream <input type="checkbox"/>
8. Flowing water in channel and 7 days since last precip >0.1" in local watershed	<input checked="" type="checkbox"/>	Stream <input type="checkbox"/>
9. Evidence watercourse has been used as a supply of drinking water	<input checked="" type="checkbox"/>	Stream <input type="checkbox"/>

NOTE: If any Primary Indicators 1-9 = "Yes", then no further investigation is necessary. However, assessors may choose to score secondary indicators as supporting evidence.

In the absence of a primary indicator, or other definitive evidence, complete the secondary indicator table on page 2 of this sheet, and provide score below.

Guidance for the interpretation and scoring of both the primary & secondary indicators is provided in *TDEC-WPC Guidance For Making Hydrologic Determinations, Version 1.5*

Overall Hydrologic Determination = STREAM

Secondary Indicator Score (if applicable) = 20.5

Justification / Notes :

Feature originates offsite from the east under Centennial Boulevard

Moderate presence of surface water observed in channel which flows south between railroad tracks and warehouse structure

Secondary Field Indicator Evaluation

A. Geomorphology (Subtotal = 8.50)	Absent	Weak	Moderate	Strong
1. Continuous bed and bank	0	1	2	3
2. Sinuous channel	0	1	2	3
3. In-channel structure: riffle-pool sequences	0	1	2	3
4. Sorting of soil textures or other substrate	0	1	2	3
5. Active/relic floodplain	0	0.5	2	1.5
6. Depositional bars or benches	0	1	2	3
7. Braided channel	0	1	2	3
8. Recent alluvial deposits	0	0.5	1	1.5
9. Natural levees	0	1	2	3
10. Headcuts	0	1	2	3
11. Grade controls	0	0.5	2	1.5
12. Natural valley or drainageway	0	0.5	1	1.5
13. At least second order channel on existing USGS or NRCS map	No = 0 <input checked="" type="checkbox"/>		Yes = 3 <input type="checkbox"/>	

B. Hydrology (Subtotal = 5.00)	Absent	Weak	Moderate	Strong
14. Subsurface flow/discharge into channel	0	1	2	3
15. Water in channel and >48 hours since sig. rain	0	1	2	3
16. Leaf litter in channel (January – September)	1.5	1	0.5	0
17. Sediment on plants or on debris	0	0.5	1	1.5
18. Organic debris lines or piles (wrack lines)	0	0.5	1	1.5
19. Hydric soils in channel bed or sides of channel	No = 0 <input checked="" type="checkbox"/>		Yes = 1.5 <input type="checkbox"/>	

C. Biology (Subtotal = 7.00)	Absent	Weak	Moderate	Strong
20. Fibrous roots in channel bed ¹	3	2	1	0
21. Rooted plants in the thalweg ¹	3	2	1	0
22. Crayfish in stream (exclude in floodplain)	0	1	2	3
23. Bivalves/mussels	0	1	2	3
24. Amphibians	0	0.5	1	1.5
25. Macroinvertebrates (record type & abundance)	0	1	2	3
26. Filamentous algae; periphyton	0	1	2	3
27. Iron oxidizing bacteria/fungus	0	0.5	1	1.5
28. Wetland plants in channel bed ²	0	0.5	1	1.5

¹ Focus is on the presence of **terrestrial** plants.

² Focus is on the presence of aquatic or wetland plants.

Total Points = 20.5

Under Normal Conditions, Watercourse is a Wet Weather Conveyance if Secondary Indicator Score < 19 points

Notes :

Bed and bank is moderately present in the upper reach but begins to fade further downslope

As bed and bank begin to weaken the floodplain for the feature strengthens

Some sorting present, as well as alluvial deposits, but the channel is bedrock lined, which occasion was grade controls

No terrestrial vegetation in the channel, but some green ash saplings were in the lower reach.

Isopods and Lymnaeidae (lunged) snails observed within the flowing waters of the reach.

Surface water was nearly throughout the OHWM width of the channel

There was no leaf litter in the channel, but some presence of wracklines was observed.

Project/Site: TBG 7211 Centennial Blvd Site City/County: Nashville / Davidson Sampling Date: 08/11/22
 Applicant/Owner: Barge Design Solutions State: TN Sampling Point: WTL-1
 Investigator(s): FCA Section, Township, Range: _____
 Landform (hillside, terrace, etc.): Floodplain Local relief (concave, convex, none): Concave Slope (%): 1-2
 Subregion (LRR or MLRA): LRR N, MLRA 123 Lat: 36.182067, Long: -86.878757 Datum: Nad83
 Soil Map Unit Name: MsD NWI classification: --
 Are climatic / hydrologic conditions on the site typical for this time of year? Yes X No _____ (If no, explain in Remarks.)
 Are Vegetation _____, Soil _____, or Hydrology _____ significantly disturbed? Are "Normal Circumstances" present? Yes X No _____
 Are Vegetation _____, Soil _____, or Hydrology _____ naturally problematic? (If needed, explain any answers in Remarks.)

SUMMARY OF FINDINGS – Attach site map showing sampling point locations, transects, important features, etc.

Hydrophytic Vegetation Present? Yes <u>X</u> No _____ Hydric Soil Present? Yes <u>X</u> No _____ Wetland Hydrology Present? Yes <u>X</u> No _____	Is the Sampled Area within a Wetland? Yes <u>X</u> No _____
Remarks:	

HYDROLOGY

Wetland Hydrology Indicators: <u>Primary Indicators</u> (minimum of one is required; check all that apply)	<u>Secondary Indicators</u> (minimum of two required)
<input type="checkbox"/> Surface Water (A1) <input type="checkbox"/> True Aquatic Plants (B14) <input checked="" type="checkbox"/> High Water Table (A2) <input type="checkbox"/> Hydrogen Sulfide Odor (C1) <input checked="" type="checkbox"/> Saturation (A3) <input type="checkbox"/> Oxidized Rhizospheres on Living Roots (C3) <input type="checkbox"/> Water Marks (B1) <input type="checkbox"/> Presence of Reduced Iron (C4) <input type="checkbox"/> Sediment Deposits (B2) <input type="checkbox"/> Recent Iron Reduction in Tilled Soils (C6) <input type="checkbox"/> Drift Deposits (B3) <input type="checkbox"/> Thin Muck Surface (C7) <input type="checkbox"/> Algal Mat or Crust (B4) <input type="checkbox"/> Other (Explain in Remarks) <input type="checkbox"/> Iron Deposits (B5) <input type="checkbox"/> Inundation Visible on Aerial Imagery (B7) <input checked="" type="checkbox"/> Water-Stained Leaves (B9) <input type="checkbox"/> Aquatic Fauna (B13)	<input type="checkbox"/> Surface Soil Cracks (B6) <input type="checkbox"/> Sparsely Vegetated Concave Surface (B8) <input checked="" type="checkbox"/> Drainage Patterns (B10) <input type="checkbox"/> Moss Trim Lines (B16) <input type="checkbox"/> Dry-Season Water Table (C2) <input type="checkbox"/> Crayfish Burrows (C8) <input type="checkbox"/> Saturation Visible on Aerial Imagery (C9) <input type="checkbox"/> Stunted or Stressed Plants (D1) <input checked="" type="checkbox"/> Geomorphic Position (D2) <input type="checkbox"/> Shallow Aquitard (D3) <input type="checkbox"/> Microtopographic Relief (D4) <input checked="" type="checkbox"/> FAC-Neutral Test (D5)

Field Observations: Surface Water Present? Yes _____ No _____ Depth (inches): _____ Water Table Present? Yes <u>X</u> No _____ Depth (inches): <u>6</u> Saturation Present? Yes <u>X</u> No _____ Depth (inches): <u>1</u> (includes capillary fringe)	Wetland Hydrology Present? Yes <u>X</u> No _____
---	---

Describe Recorded Data (stream gauge, monitoring well, aerial photos, previous inspections), if available:

Remarks:

VEGETATION (Four Strata) – Use scientific names of plants.

Sampling Point: WTL-1

Tree Stratum (Plot size: <u>30 ft</u>)	Absolute % Cover	Dominant Species?	Indicator Status
1. <u>Fraxinus pennsylvanica</u>	<u>60</u>	<u>Yes</u>	<u>FACW</u>
2. <u>Acer negundo</u>	<u>25</u>	<u>Yes</u>	<u>FAC</u>
3. _____	_____	_____	_____
4. _____	_____	_____	_____
5. _____	_____	_____	_____
6. _____	_____	_____	_____
7. _____	_____	_____	_____
	<u>85</u> =Total Cover		
	50% of total cover: <u>43</u>	20% of total cover: <u>17</u>	

Sapling/Shrub Stratum (Plot size: <u>15ft</u>)	Absolute % Cover	Dominant Species?	Indicator Status
1. <u>Fraxinus pennsylvanica</u>	<u>35</u>	<u>Yes</u>	<u>FACW</u>
2. _____	_____	_____	_____
3. _____	_____	_____	_____
4. _____	_____	_____	_____
5. _____	_____	_____	_____
6. _____	_____	_____	_____
7. _____	_____	_____	_____
8. _____	_____	_____	_____
9. _____	_____	_____	_____
	<u>35</u> =Total Cover		
	50% of total cover: <u>18</u>	20% of total cover: <u>7</u>	

Herb Stratum (Plot size: <u>5ft</u>)	Absolute % Cover	Dominant Species?	Indicator Status
1. <u>Glyceria striata</u>	<u>45</u>	<u>Yes</u>	<u>OBL</u>
2. <u>Fraxinus pennsylvanica</u>	<u>15</u>	<u>Yes</u>	<u>FACW</u>
3. <u>Pilea pumila</u>	<u>15</u>	<u>Yes</u>	<u>FACW</u>
4. _____	_____	_____	_____
5. _____	_____	_____	_____
6. _____	_____	_____	_____
7. _____	_____	_____	_____
8. _____	_____	_____	_____
9. _____	_____	_____	_____
10. _____	_____	_____	_____
11. _____	_____	_____	_____
	<u>75</u> =Total Cover		
	50% of total cover: <u>38</u>	20% of total cover: <u>15</u>	

Woody Vine Stratum (Plot size: <u>15ft</u>)	Absolute % Cover	Dominant Species?	Indicator Status
1. _____	_____	_____	_____
2. _____	_____	_____	_____
3. _____	_____	_____	_____
4. _____	_____	_____	_____
5. _____	_____	_____	_____
	_____ =Total Cover		
	50% of total cover: _____	20% of total cover: _____	

Dominance Test worksheet:

Number of Dominant Species That Are OBL, FACW, or FAC: 6 (A)

Total Number of Dominant Species Across All Strata: 6 (B)

Percent of Dominant Species That Are OBL, FACW, or FAC: 100.0% (A/B)

Prevalence Index worksheet:

Total % Cover of:	Multiply by:
OBL species <u>45</u>	x 1 = <u>45</u>
FACW species <u>125</u>	x 2 = <u>250</u>
FAC species <u>25</u>	x 3 = <u>75</u>
FACU species <u>0</u>	x 4 = <u>0</u>
UPL species <u>0</u>	x 5 = <u>0</u>
Column Totals: <u>195</u> (A)	<u>370</u> (B)
Prevalence Index = B/A = <u>1.90</u>	

Hydrophytic Vegetation Indicators:

 1 - Rapid Test for Hydrophytic Vegetation

X 2 - Dominance Test is >50%

X 3 - Prevalence Index is ≤3.0¹

 4 - Morphological Adaptations¹ (Provide supporting data in Remarks or on a separate sheet)

 Problematic Hydrophytic Vegetation¹ (Explain)

¹Indicators of hydric soil and wetland hydrology must be present, unless disturbed or problematic.

Definitions of Four Vegetation Strata:

Tree – Woody plants, excluding vines, 3 in. (7.6 cm) or more in diameter at breast height (DBH), regardless of height.

Sapling/Shrub – Woody plants, excluding vines, less than 3 in. DBH and greater than or equal to 3.28 ft (1 m) tall.

Herb – All herbaceous (non-woody) plants, regardless of size, and woody plants less than 3.28 ft tall.

Woody Vine – All woody vines greater than 3.28 ft in height.

Hydrophytic Vegetation Present? Yes X No _____

Remarks: (Include photo numbers here or on a separate sheet.)

SOIL

Sampling Point: WTL-1

Profile Description: (Describe to the depth needed to document the indicator or confirm the absence of indicators.)								
Depth (inches)	Matrix		Redox Features				Texture	Remarks
	Color (moist)	%	Color (moist)	%	Type ¹	Loc ²		
0-3	10YR 3/2	100					Loamy/Clayey	
3-18	10YR 4/2	75	10YR 5/6	25	C	M	Loamy/Clayey	Prominent redox concentrations

¹Type: C=Concentration, D=Depletion, RM=Reduced Matrix, MS=Masked Sand Grains.

²Location: PL=Pore Lining, M=Matrix.

Hydric Soil Indicators:

- Histosol (A1)
- Histic Epipedon (A2)
- Black Histic (A3)
- Hydrogen Sulfide (A4)
- Stratified Layers (A5)
- 2 cm Muck (A10) **(LRR N)**
- Depleted Below Dark Surface (A11)
- Thick Dark Surface (A12)
- Sandy Mucky Mineral (S1)
- Sandy Gleyed Matrix (S4)
- Sandy Redox (S5)
- Stripped Matrix (S6)
- Dark Surface (S7)

- Polyvalue Below Surface (S8) **(MLRA 147, 148)**
- Thin Dark Surface (S9) **(MLRA 147, 148)**
- Loamy Mucky Mineral (F1) **(MLRA 136)**
- Loamy Gleyed Matrix (F2)
- Depleted Matrix (F3)
- Redox Dark Surface (F6)
- Depleted Dark Surface (F7)
- Redox Depressions (F8)
- Iron-Manganese Masses (F12) **(LRR N, MLRA 136)**
- Umbric Surface (F13) **(MLRA 122, 136)**
- Piedmont Floodplain Soils (F19) **(MLRA 148)**
- Red Parent Material (F21) **(MLRA 127, 147, 148)**

Indicators for Problematic Hydric Soils³:

- 2 cm Muck (A10) **(MLRA 147)**
- Coast Prairie Redox (A16) **(MLRA 147, 148)**
- Piedmont Floodplain Soils (F19) **(MLRA 136, 147)**
- Red Parent Material (F21) **(outside MLRA 127, 147, 148)**
- Very Shallow Dark Surface (F22)
- Other (Explain in Remarks)

³Indicators of hydrophytic vegetation and wetland hydrology must be present, unless disturbed or problematic.

Restrictive Layer (if observed):

Type: _____
 Depth (inches): _____

Hydric Soil Present? Yes No

Remarks:

Project/Site: TBG 7211 Centennial Blvd Site City/County: Nashville / Davidson Sampling Date: 08/11/22
 Applicant/Owner: Barge Design Solutions State: TN Sampling Point: WTL-2
 Investigator(s): FCA Section, Township, Range: _____
 Landform (hillside, terrace, etc.): Depression Local relief (concave, convex, none): Concave Slope (%): 0-1
 Subregion (LRR or MLRA): LRR N, MLRA 123 Lat: 36.182911, Long: -86.878281 Datum: Nad83
 Soil Map Unit Name: MsD NWI classification: --

Are climatic / hydrologic conditions on the site typical for this time of year? Yes X No _____ (If no, explain in Remarks.)
 Are Vegetation _____, Soil _____, or Hydrology _____ significantly disturbed? Are "Normal Circumstances" present? Yes X No _____
 Are Vegetation _____, Soil _____, or Hydrology _____ naturally problematic? (If needed, explain any answers in Remarks.)

SUMMARY OF FINDINGS – Attach site map showing sampling point locations, transects, important features, etc.

Hydrophytic Vegetation Present? Yes <u>X</u> No _____ Hydric Soil Present? Yes <u>X</u> No _____ Wetland Hydrology Present? Yes <u>X</u> No _____	Is the Sampled Area within a Wetland? Yes <u>X</u> No _____
Remarks:	

HYDROLOGY

Wetland Hydrology Indicators: <u>Primary Indicators</u> (minimum of one is required; check all that apply)	<u>Secondary Indicators</u> (minimum of two required)
<input type="checkbox"/> Surface Water (A1) <input type="checkbox"/> True Aquatic Plants (B14) <input type="checkbox"/> High Water Table (A2) <input type="checkbox"/> Hydrogen Sulfide Odor (C1) <input checked="" type="checkbox"/> Saturation (A3) <input type="checkbox"/> Oxidized Rhizospheres on Living Roots (C3) <input type="checkbox"/> Water Marks (B1) <input type="checkbox"/> Presence of Reduced Iron (C4) <input type="checkbox"/> Sediment Deposits (B2) <input type="checkbox"/> Recent Iron Reduction in Tilled Soils (C6) <input type="checkbox"/> Drift Deposits (B3) <input type="checkbox"/> Thin Muck Surface (C7) <input type="checkbox"/> Algal Mat or Crust (B4) <input type="checkbox"/> Other (Explain in Remarks) <input type="checkbox"/> Iron Deposits (B5) <input type="checkbox"/> Inundation Visible on Aerial Imagery (B7) <input checked="" type="checkbox"/> Water-Stained Leaves (B9) <input type="checkbox"/> Aquatic Fauna (B13)	<input type="checkbox"/> Surface Soil Cracks (B6) <input type="checkbox"/> Sparsely Vegetated Concave Surface (B8) <input type="checkbox"/> Drainage Patterns (B10) <input type="checkbox"/> Moss Trim Lines (B16) <input type="checkbox"/> Dry-Season Water Table (C2) <input type="checkbox"/> Crayfish Burrows (C8) <input type="checkbox"/> Saturation Visible on Aerial Imagery (C9) <input type="checkbox"/> Stunted or Stressed Plants (D1) <input type="checkbox"/> Geomorphic Position (D2) <input checked="" type="checkbox"/> Shallow Aquitard (D3) <input checked="" type="checkbox"/> Microtopographic Relief (D4) <input checked="" type="checkbox"/> FAC-Neutral Test (D5)

Field Observations: Surface Water Present? Yes _____ No <u>X</u> Depth (inches): _____ Water Table Present? Yes _____ No <u>X</u> Depth (inches): _____ Saturation Present? Yes <u>X</u> No _____ Depth (inches): <u>2</u> (includes capillary fringe)	Wetland Hydrology Present? Yes <u>X</u> No _____
---	---

Describe Recorded Data (stream gauge, monitoring well, aerial photos, previous inspections), if available:

Remarks:

VEGETATION (Four Strata) – Use scientific names of plants.

Sampling Point: WTL-2

Tree Stratum (Plot size: <u>30 ft</u>)	Absolute % Cover	Dominant Species?	Indicator Status
1. _____	_____	_____	_____
2. _____	_____	_____	_____
3. _____	_____	_____	_____
4. _____	_____	_____	_____
5. _____	_____	_____	_____
6. _____	_____	_____	_____
7. _____	_____	_____	_____
_____ = Total Cover			
50% of total cover: _____ 20% of total cover: _____			

Sapling/Shrub Stratum (Plot size: <u>15ft</u>)	Absolute % Cover	Dominant Species?	Indicator Status
1. _____	_____	_____	_____
2. _____	_____	_____	_____
3. _____	_____	_____	_____
4. _____	_____	_____	_____
5. _____	_____	_____	_____
6. _____	_____	_____	_____
7. _____	_____	_____	_____
8. _____	_____	_____	_____
9. _____	_____	_____	_____
_____ = Total Cover			
50% of total cover: _____ 20% of total cover: _____			

Herb Stratum (Plot size: <u>5ft</u>)	Absolute % Cover	Dominant Species?	Indicator Status
1. <u>Carex vulpinoidea</u>	<u>35</u>	<u>Yes</u>	<u>OBL</u>
2. <u>Cyperus esculentus</u>	<u>30</u>	<u>Yes</u>	<u>FACW</u>
3. <u>Rumex crispus</u>	<u>15</u>	<u>No</u>	<u>FAC</u>
4. <u>Persicaria hydropiper</u>	<u>25</u>	<u>Yes</u>	<u>OBL</u>
5. _____	_____	_____	_____
6. _____	_____	_____	_____
7. _____	_____	_____	_____
8. _____	_____	_____	_____
9. _____	_____	_____	_____
10. _____	_____	_____	_____
11. _____	_____	_____	_____
_____ = Total Cover			
50% of total cover: <u>53</u> 20% of total cover: <u>21</u>			

Woody Vine Stratum (Plot size: <u>15ft</u>)	Absolute % Cover	Dominant Species?	Indicator Status
1. _____	_____	_____	_____
2. _____	_____	_____	_____
3. _____	_____	_____	_____
4. _____	_____	_____	_____
5. _____	_____	_____	_____
_____ = Total Cover			
50% of total cover: _____ 20% of total cover: _____			

Dominance Test worksheet:

Number of Dominant Species That Are OBL, FACW, or FAC: 3 (A)

Total Number of Dominant Species Across All Strata: 3 (B)

Percent of Dominant Species That Are OBL, FACW, or FAC: 100.0% (A/B)

Prevalence Index worksheet:

Total % Cover of:	Multiply by:
OBL species <u>60</u>	x 1 = <u>60</u>
FACW species <u>30</u>	x 2 = <u>60</u>
FAC species <u>15</u>	x 3 = <u>45</u>
FACU species <u>0</u>	x 4 = <u>0</u>
UPL species <u>0</u>	x 5 = <u>0</u>
Column Totals: <u>105</u> (A)	<u>165</u> (B)
Prevalence Index = B/A = <u>1.57</u>	

Hydrophytic Vegetation Indicators:

 1 - Rapid Test for Hydrophytic Vegetation

X 2 - Dominance Test is >50%

X 3 - Prevalence Index is ≤3.0¹

 4 - Morphological Adaptations¹ (Provide supporting data in Remarks or on a separate sheet)

 Problematic Hydrophytic Vegetation¹ (Explain)

¹Indicators of hydric soil and wetland hydrology must be present, unless disturbed or problematic.

Definitions of Four Vegetation Strata:

Tree – Woody plants, excluding vines, 3 in. (7.6 cm) or more in diameter at breast height (DBH), regardless of height.

Sapling/Shrub – Woody plants, excluding vines, less than 3 in. DBH and greater than or equal to 3.28 ft (1 m) tall.

Herb – All herbaceous (non-woody) plants, regardless of size, and woody plants less than 3.28 ft tall.

Woody Vine – All woody vines greater than 3.28 ft in height.

Hydrophytic Vegetation Present? Yes X No

Remarks: (Include photo numbers here or on a separate sheet.)

SOIL

Sampling Point: WTL-2

Profile Description: (Describe to the depth needed to document the indicator or confirm the absence of indicators.)								
Depth (inches)	Matrix		Redox Features				Texture	Remarks
	Color (moist)	%	Color (moist)	%	Type ¹	Loc ²		
0-2	10YR 3/2	100					Loamy/Clayey	
2-4	10YR 5/1	100					Loamy/Clayey	

¹Type: C=Concentration, D=Depletion, RM=Reduced Matrix, MS=Masked Sand Grains.

²Location: PL=Pore Lining, M=Matrix.

Hydric Soil Indicators:

- Histosol (A1)
- Histic Epipedon (A2)
- Black Histic (A3)
- Hydrogen Sulfide (A4)
- Stratified Layers (A5)
- 2 cm Muck (A10) **(LRR N)**
- Depleted Below Dark Surface (A11)
- Thick Dark Surface (A12)
- Sandy Mucky Mineral (S1)
- Sandy Gleyed Matrix (S4)
- Sandy Redox (S5)
- Stripped Matrix (S6)
- Dark Surface (S7)

- Polyvalue Below Surface (S8) **(MLRA 147, 148)**
- Thin Dark Surface (S9) **(MLRA 147, 148)**
- Loamy Mucky Mineral (F1) **(MLRA 136)**
- Loamy Gleyed Matrix (F2)
- Depleted Matrix (F3)
- Redox Dark Surface (F6)
- Depleted Dark Surface (F7)
- Redox Depressions (F8)
- Iron-Manganese Masses (F12) **(LRR N, MLRA 136)**
- Umbric Surface (F13) **(MLRA 122, 136)**
- Piedmont Floodplain Soils (F19) **(MLRA 148)**
- Red Parent Material (F21) **(MLRA 127, 147, 148)**

Indicators for Problematic Hydric Soils³:

- 2 cm Muck (A10) **(MLRA 147)**
- Coast Prairie Redox (A16) **(MLRA 147, 148)**
- Piedmont Floodplain Soils (F19) **(MLRA 136, 147)**
- Red Parent Material (F21) **(outside MLRA 127, 147, 148)**
- Very Shallow Dark Surface (F22)
- Other (Explain in Remarks)

³Indicators of hydrophytic vegetation and wetland hydrology must be present, unless disturbed or problematic.

Restrictive Layer (if observed):

Type: bedrock
 Depth (inches): 4

Hydric Soil Present? Yes No

Remarks:

Project/Site: TBG 7211 Centennial Blvd Site City/County: Nashville / Davidson Sampling Date: 08/11/22
 Applicant/Owner: Barge Design Solutions State: TN Sampling Point: UPL-1/2
 Investigator(s): FCA Section, Township, Range: _____
 Landform (hillside, terrace, etc.): Hillslope Local relief (concave, convex, none): Convex Slope (%): 1-3
 Subregion (LRR or MLRA): LRR N, MLRA 123 Lat: 36.182825 Long: -86.878661 Datum: Nad83
 Soil Map Unit Name: MsD NWI classification: --

Are climatic / hydrologic conditions on the site typical for this time of year? Yes X No _____ (If no, explain in Remarks.)
 Are Vegetation _____, Soil _____, or Hydrology _____ significantly disturbed? Are "Normal Circumstances" present? Yes X No _____
 Are Vegetation _____, Soil _____, or Hydrology _____ naturally problematic? (If needed, explain any answers in Remarks.)

SUMMARY OF FINDINGS – Attach site map showing sampling point locations, transects, important features, etc.

Hydrophytic Vegetation Present? Yes _____ No <u>X</u> Hydric Soil Present? Yes <u>X</u> No _____ Wetland Hydrology Present? Yes _____ No <u>X</u>	Is the Sampled Area within a Wetland? Yes _____ No <u>X</u>
Remarks:	

HYDROLOGY

Wetland Hydrology Indicators: <u>Primary Indicators (minimum of one is required; check all that apply)</u> ___ Surface Water (A1) ___ True Aquatic Plants (B14) ___ High Water Table (A2) ___ Hydrogen Sulfide Odor (C1) ___ Saturation (A3) ___ Oxidized Rhizospheres on Living Roots (C3) ___ Water Marks (B1) ___ Presence of Reduced Iron (C4) ___ Sediment Deposits (B2) ___ Recent Iron Reduction in Tilled Soils (C6) ___ Drift Deposits (B3) ___ Thin Muck Surface (C7) ___ Algal Mat or Crust (B4) ___ Other (Explain in Remarks) ___ Iron Deposits (B5) ___ Inundation Visible on Aerial Imagery (B7) ___ Water-Stained Leaves (B9) ___ Aquatic Fauna (B13)	<u>Secondary Indicators (minimum of two required)</u> ___ Surface Soil Cracks (B6) ___ Sparsely Vegetated Concave Surface (B8) ___ Drainage Patterns (B10) ___ Moss Trim Lines (B16) ___ Dry-Season Water Table (C2) ___ Crayfish Burrows (C8) ___ Saturation Visible on Aerial Imagery (C9) ___ Stunted or Stressed Plants (D1) ___ Geomorphic Position (D2) <u>X</u> Shallow Aquitard (D3) ___ Microtopographic Relief (D4) ___ FAC-Neutral Test (D5)
---	---

Field Observations: Surface Water Present? Yes _____ No <u>X</u> Depth (inches): _____ Water Table Present? Yes _____ No <u>X</u> Depth (inches): _____ Saturation Present? Yes _____ No <u>X</u> Depth (inches): _____ (includes capillary fringe)	Wetland Hydrology Present? Yes _____ No <u>X</u>
--	---

Describe Recorded Data (stream gauge, monitoring well, aerial photos, previous inspections), if available:

Remarks:

 No positive indicators of hydrology observed in the upland area

VEGETATION (Four Strata) – Use scientific names of plants.

Sampling Point: UPL-1/2

Tree Stratum (Plot size: <u>30 ft</u>)	Absolute % Cover	Dominant Species?	Indicator Status
1. _____	_____	_____	_____
2. _____	_____	_____	_____
3. _____	_____	_____	_____
4. _____	_____	_____	_____
5. _____	_____	_____	_____
6. _____	_____	_____	_____
7. _____	_____	_____	_____
	_____ = Total Cover		
50% of total cover: _____	20% of total cover: _____		

Sapling/Shrub Stratum (Plot size: <u>15ft</u>)	Absolute % Cover	Dominant Species?	Indicator Status
1. <u>Rubus argutus</u>	<u>45</u>	<u>Yes</u>	<u>FACU</u>
2. _____	_____	_____	_____
3. _____	_____	_____	_____
4. _____	_____	_____	_____
5. _____	_____	_____	_____
6. _____	_____	_____	_____
7. _____	_____	_____	_____
8. _____	_____	_____	_____
9. _____	_____	_____	_____
	<u>45</u> = Total Cover		
50% of total cover: <u>23</u>	20% of total cover: <u>9</u>		

Herb Stratum (Plot size: <u>5ft</u>)	Absolute % Cover	Dominant Species?	Indicator Status
1. <u>Verbesina occidentalis</u>	<u>25</u>	<u>Yes</u>	<u>FACU</u>
2. <u>Andropogon virginicus</u>	<u>25</u>	<u>Yes</u>	<u>FACU</u>
3. <u>Daucus carota</u>	<u>10</u>	<u>No</u>	<u>UPL</u>
4. <u>Plantago lanceolata</u>	<u>15</u>	<u>Yes</u>	<u>UPL</u>
5. _____	_____	_____	_____
6. _____	_____	_____	_____
7. _____	_____	_____	_____
8. _____	_____	_____	_____
9. _____	_____	_____	_____
10. _____	_____	_____	_____
11. _____	_____	_____	_____
	<u>75</u> = Total Cover		
50% of total cover: <u>38</u>	20% of total cover: <u>15</u>		

Woody Vine Stratum (Plot size: <u>15ft</u>)	Absolute % Cover	Dominant Species?	Indicator Status
1. _____	_____	_____	_____
2. _____	_____	_____	_____
3. _____	_____	_____	_____
4. _____	_____	_____	_____
5. _____	_____	_____	_____
	_____ = Total Cover		
50% of total cover: _____	20% of total cover: _____		

Dominance Test worksheet:

Number of Dominant Species That Are OBL, FACW, or FAC: 0 (A)

Total Number of Dominant Species Across All Strata: 4 (B)

Percent of Dominant Species That Are OBL, FACW, or FAC: 0.0% (A/B)

Prevalence Index worksheet:

Total % Cover of:	Multiply by:
OBL species <u>0</u>	x 1 = <u>0</u>
FACW species <u>0</u>	x 2 = <u>0</u>
FAC species <u>0</u>	x 3 = <u>0</u>
FACU species <u>95</u>	x 4 = <u>380</u>
UPL species <u>25</u>	x 5 = <u>125</u>
Column Totals: <u>120</u> (A)	<u>505</u> (B)
Prevalence Index = B/A = <u>4.21</u>	

Hydrophytic Vegetation Indicators:

___ 1 - Rapid Test for Hydrophytic Vegetation

___ 2 - Dominance Test is >50%

___ 3 - Prevalence Index is ≤3.0¹

___ 4 - Morphological Adaptations¹ (Provide supporting data in Remarks or on a separate sheet)

___ Problematic Hydrophytic Vegetation¹ (Explain)

¹Indicators of hydric soil and wetland hydrology must be present, unless disturbed or problematic.

Definitions of Four Vegetation Strata:

Tree – Woody plants, excluding vines, 3 in. (7.6 cm) or more in diameter at breast height (DBH), regardless of height.

Sapling/Shrub – Woody plants, excluding vines, less than 3 in. DBH and greater than or equal to 3.28 ft (1 m) tall.

Herb – All herbaceous (non-woody) plants, regardless of size, and woody plants less than 3.28 ft tall.

Woody Vine – All woody vines greater than 3.28 ft in height.

Hydrophytic Vegetation Present? Yes ___ No X

Remarks: (Include photo numbers here or on a separate sheet.)

SOIL

Sampling Point: UPL-1/2

Profile Description: (Describe to the depth needed to document the indicator or confirm the absence of indicators.)								
Depth (inches)	Matrix		Redox Features				Texture	Remarks
	Color (moist)	%	Color (moist)	%	Type ¹	Loc ²		
0-2	10YR 3/3	100					Loamy/Clayey	
2-5	10YR 5/4	100					Loamy/Clayey	

¹Type: C=Concentration, D=Depletion, RM=Reduced Matrix, MS=Masked Sand Grains.

²Location: PL=Pore Lining, M=Matrix.

Hydric Soil Indicators:

- Histosol (A1)
- Histic Epipedon (A2)
- Black Histic (A3)
- Hydrogen Sulfide (A4)
- Stratified Layers (A5)
- 2 cm Muck (A10) **(LRR N)**
- Depleted Below Dark Surface (A11)
- Thick Dark Surface (A12)
- Sandy Mucky Mineral (S1)
- Sandy Gleyed Matrix (S4)
- Sandy Redox (S5)
- Stripped Matrix (S6)
- Dark Surface (S7)

- Polyvalue Below Surface (S8) **(MLRA 147, 148)**
- Thin Dark Surface (S9) **(MLRA 147, 148)**
- Loamy Mucky Mineral (F1) **(MLRA 136)**
- Loamy Gleyed Matrix (F2)
- Depleted Matrix (F3)
- Redox Dark Surface (F6)
- Depleted Dark Surface (F7)
- Redox Depressions (F8)
- Iron-Manganese Masses (F12) **(LRR N, MLRA 136)**
- Umbric Surface (F13) **(MLRA 122, 136)**
- Piedmont Floodplain Soils (F19) **(MLRA 148)**
- Red Parent Material (F21) **(MLRA 127, 147, 148)**

Indicators for Problematic Hydric Soils³:

- 2 cm Muck (A10) **(MLRA 147)**
- Coast Prairie Redox (A16) **(MLRA 147, 148)**
- Piedmont Floodplain Soils (F19) **(MLRA 136, 147)**
- Red Parent Material (F21) **(outside MLRA 127, 147, 148)**
- Very Shallow Dark Surface (F22)
- Other (Explain in Remarks)

³Indicators of hydrophytic vegetation and wetland hydrology must be present, unless disturbed or problematic.

Restrictive Layer (if observed):

Type: _____ bedrock
 Depth (inches): _____ 5

Hydric Soil Present? Yes No

Remarks:

APPENDIX E - PHOTOGRAPHIC SUMMARY

Photo Summary

Summary of Environmental Features Nashville, Davidson County, Tennessee

Page 1 of 3



Photo: 1
By: F. Amatucci
Date: August 11, 2022
Feature: STR-1
Lat: 36.183201
Long: -86.878535

Representative conditions of STR-1 at the start of the reach.



Photo: 2
By: F. Amatucci
Date: August 11, 2022
Feature: STR-1
Lat: 36.182776
Long: -86.878785

Representative conditions of STR-1 before a slight loss of bed and bank within WTL-1.

Photo Summary

Summary of Environmental Features Nashville, Davidson County, Tennessee

Page 2 of 3



Photo: 3
By: F. Amatucci
Date: August 11, 2022
Feature: SWD-1
Lat: 36.181705
Long: -86.877865

Representative conditions of SWD-1 adjacent to the warehouse structure.



Photo: 4
By: F. Amatucci
Date: August 11, 2022
Feature: SWD-1
Lat: 36.181531
Long: -86.878712

Representative conditions of SWD-1 prior to flowing offsite behind the warehouse structure.

Photo Summary

Summary of Environmental Features Nashville, Davidson County, Tennessee

Page 3 of 3



Photo: 5
By: F. Amatucci
Date: August 11, 2022
Feature: WTL-1
Lat: 36.182088
Long: -86.878748

Representative conditions of WTL-1 serving as a floodplain for STR-1.



Photo: 6
By: F. Amatucci
Date: August 11, 2022
Feature: WTL-2
Lat: 36.182924
Long: -86.878282

Representative conditions of depressional wetland WTL-2.

November 18, 2022

USACE Regulatory Branch
Nashville District
3701 Bell Road
Nashville, TN 37214

RE: Approved Jurisdictional Determination Request Package for the
TBG Triune Residuals Management Project
Nashville, Davidson County, Tennessee

To whom it may concern,

Barge Design Solutions, Inc. (Barge) has been retained to identify natural resources on a property that is approximately 5.5 acres (project study area) for a proposed commercial development as part of a local waste services facility, located in Nashville, Davidson County, Tennessee. The project study area is located at 7211 Centennial Boulevard, west of the Carlisle automotive glass manufacturing facility in the Cockrill Bend commercial district of Nashville. The project study area includes parcel Number. 07900000401. Barge is submitting the attached Approved Jurisdictional Determination (AJD) Package for concurrence with observed features within the project study area.

Attached to this letter is the AJD request package of all wetland and non-wetland waters that have been documented within the project study area. I, Frank Amatucci (TN-QHP #1203-TN21), attest that the information being submitted in this AJD package is true, accurate, and complete to the best of my ability. If you have any questions or require additional information, please contact me by phone at 615-252-4406 or email at frank.amatucci@bargedesign.com. Thank you!

Sincerely,



Frank Amatucci, TN-QHP
Biologist
Barge Design Solutions, Inc.

c: Jason Repsher, PG, Barge Design Solutions, Inc
Josh Blecker, PE, Barge Design Solutions, Inc.
Sidney Brian, Trinity Business Group

Barge project # 3712202



TRIUNE RESIDUALS MANAGEMENT PROJECT
APPROVED JURISDICTIONAL DETERMINATION
REQUEST PACKAGE

Prepared For: Trinity Business Group

Sent To: USACE Regulatory Branch
Nashville District
3701 Bell Road
Nashville, TN 37214

CONTENTS

EXECUTIVE SUMMARY	1
1.0 INTRODUCTION.....	2
1.1 Study Area.....	2
2.0 ENVIRONMENTAL REVIEW.....	2
2.1 Field Investigation Methodology.....	3
2.1.1 Waterbody Identification	3
2.1.2 Wetland Boundary Identification.....	3
3.0 RESULTS.....	3
3.1 Non-Wetland Waters.....	4
3.2 Wetlands.....	4
4.0 SUMMARY.....	5

APPENDICES

APPENDIX A – USACE JURISDICTIONAL DETERMINATION FORM

APPENDIX B - FIGURES

APPENDIX C – NON-WETLAND FEATURES AND WETLANDS TABLES

APPENDIX D - STREAM AND WETLAND DETERMINATION DATA FORMS

APPENDIX E - PHOTOGRAPHIC SUMMARY

EXECUTIVE SUMMARY

Barge Design Solutions, Inc. (Barge) has been retained to identify natural resources on a property that is approximately 5.5 acres (project study area) for a proposed commercial development as part of a local waste services facility, located in Nashville, Davidson County, Tennessee. The project study area is located at 7211 Centennial Boulevard, west of the Carlisle automotive glass manufacturing facility in the Cockrill Bend commercial district of Nashville. The project study area includes parcel Number. 07900000401.

Barge is submitting the attached Approved Jurisdictional Determination (AJD) Package for concurrence with observed features within the project study area. The Approved Jurisdictional Determinations performed for the project were conducted by Frank Amatucci (TN-QHP #1203-TN21). In total, three potentially jurisdictional and one non-jurisdictional features were identified within the project study area, all of which were considered as wetlands, intermittent stream, and a stormwater drainage swale. These jurisdictional and non-jurisdictional resource features were identified during the field investigation of the project study area. The delineated resource features are described in this AJD Package, as well as the methodologies utilized to determine each feature's jurisdictional status and the figures and tables that represent the length, acreage, and location within the project study area.

Property Owner Requesting AJD

Trinity Business Group, LLC
Sidney Brian
5800 One Perkins Pl. Ste. 6A
Baton Rouge, LA, 70808
Phone: 225-766-1443
Email: sbrian@trinitybusinessgroup.net

1.0 INTRODUCTION

The purpose of the environmental assessment was to determine the extent of potential onsite jurisdictional wetlands and non-wetland waters pursuant to the state and federal rules and regulations. The information provided in the attached AJD Package characterizes the existing wetlands, streams, and other non-wetland waters that may be used in an effort to avoid or minimize impacts to identified resources.

1.1 Study Area

The project study area was historically utilized for as an industrial warehouse and affiliated truck parking, especially within the southern half within parcel No. 07900000401. The remaining northern area was observed as fragmented woodland and open fallow field. The wooded portions of the project study area ranged between scrub/shrubland and early successional urban forest. A Project Location Map depicting the area can be found in Appendix B, Figure 1. Other surrounding properties are primarily commercial.

The project study area is located approximately 0.4 miles north of the intersection of Centennial Place and Centennial Boulevard in Nashville, Davidson County, Tennessee (Appendix B, Figure 1). This area falls within the Interior Plateau (71) Tennessee ecoregion and is further categorized into the Outer Nashville Basin (71h) physiographic region of Tennessee. The project study area is within the Scottsboro, Tennessee, topographic quadrangle (Appendix B, Figure 2), and the property is located within the Indian Creek-Cumberland River (051302020306) lower HUC-12 watershed, which is located within the Lower Cumberland-Sycamore HUC-8 watershed (05130202), which is ultimately within the Cumberland River Basin (Appendix B, Figure 3).

2.0 ENVIRONMENTAL REVIEW

Prior to visiting the project study area, a resource review of available background site information was conducted using the U.S. Fish and Wildlife Service's (USFWS) National Wetland Inventory (NWI) database to determine if wetlands could be found within the area. Topographic maps and the United States Geological Survey (USGS) National Hydrography Dataset (NAJD) were evaluated for potential jurisdictional waters, and the United States Department of Agriculture (USDA) Natural Resources Conservation Service's (NRCS) Web Soil Survey was reviewed for potential of hydric soils. Additionally, major landscapes and vegetation units were identified using aerial imagery prior to surveying the study area and again in the field before beginning field work.

2.1 Field Investigation Methodology

2.1.1 Waterbody Identification

For the purpose of this report, any ephemeral or more persistent drainages were characterized by the presence of two or more Ordinary High-Water Mark (OHWM) indicators using the 2005 *U.S. Army Corps of Engineers (USACE) Regulatory Guidance Letter 05-05* and proximity to other adjoining jurisdictional features (i.e., wetlands and/or intermittent or perennial streams). Streams located within the project study area were verified, and coordinates of the centerline were obtained with a GPS unit.

Additionally, waterbodies were analyzed with the Tennessee Department of Environment and Conservation's (TDEC) "Guidance for Making Approved Jurisdictional Determinations" to accurately determine the jurisdictional status of Waters of the State. Approved Jurisdictional Determinations (AJD) were conducted by Frank Amatucci (TN-QHP #1203-TN21). The TDEC AJD Field Data Sheets for all observed streams and wet weather conveyances are provided in Appendix D.

2.1.2 Wetland Boundary Identification

Wetland determinations were conducted by Barge biologists through observing hydrophytic vegetation, hydric soils, and wetland hydrology according to the USACE *Regional Supplement to the Corps of Engineers Wetland Delineation Manual: Eastern Mountains and Piedmont Region, Version 2.0*. Sample points were chosen based upon representative portions of the study area to confirm visual estimates of field indicators. The Eastern Mountains and Piedmont Regional Wetland Determination Data Forms were completed at wetland and upland sample points (Appendix D). The boundaries of the wetlands were then marked in the field with pink flagging, and coordinates were obtained with a GPS unit.

3.0 RESULTS

On August 11, 2022, Barge biologist performed a field survey within the project study area to determine the presence or absence of jurisdictional waters. Both the USACE and TDEC methodologies were utilized to determine the jurisdiction of wetlands and non-wetland waters within the project study area.

In total, three potentially jurisdictional and one non-jurisdictional features were identified within the project study area, all of which were considered as wetlands, intermittent stream, and a stormwater drainage swale. The sections below detail the features that were delineated within the project study area. The features identified on site are listed in Table 1 and Table 2 (Appendix C) and are displayed in Figure 6 (Appendix B).

3.1 Non-Wetland Waters

Barge biologist Frank Amatucci (TN-QHP #1203-TN21) conducted the Approved Jurisdictional Determination (AJD) site investigation in accordance with TDEC Rule 0400-40-17-.04. In addition, water features were considered regarding the Regulatory Guidance Letter No. 05-05 for ephemeral streams. The site visit was conducted more than 48 hours following a significant rain event of greater than 1.0 inch in a 24-hour period. Upon commencement of the study, 0.83 inches of precipitation was observed in the preceding 7 days (CoCoRaHS STA# TN-DV-138). In the preceding 30 days, 2.04 inches of rain were observed. The precipitation for the preceding three months is considered “wetter than normal” based on the 30-year normal (Appendix D).

One intermittent stream (STR) and one stormwater drainage swale (SWD) were delineated within the project study area. These features were based current site conditions and secondary indicators while conducting the AJD. Below are brief descriptions of the delineated waterbody features within the project study area. Figure 6 -- Existing Conditions Map (Appendix B) illustrates the locations of the streams and man-made drainage swale within the project study area, and Table 1 (Appendix C) details the locations and lengths of each feature. Furthermore, photographs of each feature are provided in Appendix E, and the AJD data form is provided in Appendix D.

STR-1 was observed as an intermittent stream along the northern and western limits of the project study area. The delineated stream was observed with a moderate presence of baseflow, which traversed to the southwest into wetland (WTL) WTL-1, where the defined channel of the stream continues offsite to the southwest. Bed and bank upslope of WTL-1 is moderately present throughout the inspected reach, as well as Ordinary High-Water Mark (OHWM) indicators. STR-1 had as channel bottom composed of bedrock, cobble, and sand. STR-1 is assumed to be jurisdictional to TDEC and the USACE.

SWD-1 was observed as a man-made drainage swale north of the existing warehouse structure within the project study area. The man-made drainage swale originates from a stormwater grate at the entrance of the building and is conveyed to the west along the northside of the warehouse to the offsite downstream portion of STR-1. SWD-1 was observed with no visible indication of channel formation and was entirely rip-rapped within the project study area. SWD-1 is assumed to be non-jurisdictional to TDEC as a wet weather conveyance and to the USACE.

3.2 Wetlands

Two wetlands (WTL) were observed within the project study area. The delineated wetlands were observed as Palustrine Emergent (PEM) and Palustrine Forested (PFO) wetland features. Each wetland was verified with the positive identification of suitable hydrology, hydrophytic vegetation, and hydric soils. Below are brief descriptions of the delineated wetland features within the project study area. The locations of the delineated wetlands are provided in Figure 6 -- Existing Conditions Map (Appendix B), and Table 2 (Appendix C) details the location and acreage of each

wetland. A photograph of each wetland feature is provided in Appendix E, and the wetland determination data forms are provided in Appendix D.

WTL-1 was observed as a floodplain PFO wetland along the stream valley of STR-1 in the western portion of the project study area. The floodplain wetland is situated at the downslope portion of STR-1, where bed and bank begin to weaken. All excess surface water drains back into STR-1 at the western limit of the project study area and potential other Waters of the United States (WOTUS). WTL-1 was observed with a presence of saturation, a perched water table, and water-stained leaves, indicating positive wetland hydrology. The wetland was observed with a dominance of hydrophytic vegetation such as green ash (*Fraxinus pensylvanica*) in the tree and sapling stratum; and fowl mannagrass (*Glyceria striata*) and clear wed (*Pilea pumila*) in the herbaceous stratum. Hydric soils were also documented in WTL-1, which were observed with a shallow dark layer underlain by depleted hydric soils with a presence of redoximorphic concentrations. Due to the potential connection to other WOTUS, WTL-1 is assumed to be jurisdictional to TDEC and the USACE.

WTL-2 was observed as a PEM depressional wetland in the northern portion of the project study area. The wetland is likely a man-made depressional feature on top of shallow bedrock. No observable outfall, inlet, or surface water connection to other water resources was determined. Therefore, WTL-2 was determined to be isolated from other WOTUS. WTL-2 was observed with a presence of saturation and water-stained leaves, indicating positive wetland hydrology. The wetland was observed with a dominance of hydrophytic vegetation such as fox sedge (*Carex vulpinoidea*), nut sedge (*Cyperus esculentus*), and pepper weed (*Persicaria hydropiper*) in the herbaceous stratum. Shallow hydric soils were also documented in WTL-2, which were observed with a thin dark layer underlain by depleted hydric soils on top of shallow bedrock. Due to the lack of observable connection to other WOTUS, WTL-2 is assumed to be isolated and non-jurisdictional to the USACE and only jurisdictional to TDEC.

4.0 SUMMARY

Two wetlands, one intermittent stream, and one man-made stormwater drainage swale were identified during the field investigation of the project study area. The Existing Conditions Map (Figure 6, Appendix B) visually represents the boundaries of the wetlands and non-wetland waters delineated within the project area. Table 1 and Table 2 (Appendix C) also summarize the current locations and linear footages or acres of each feature, and the determination data forms for the delineated resources are provided in Appendix D.

APPENDIX A – USACE JURISDICTIONAL DETERMINATION FORM



Nashville District Request for a Jurisdictional Determination Form

This format can be used when you want to determine if areas on your property fall under regulatory requirements of the U.S. Army Corps of Engineers (Corps). Please supply the following information and supporting documents described below. This form can be filled out online and then printed. **It must be signed by the property owner** to be considered a formal request. We require original signatures; faxes are not acceptable. Submitting this request authorizes the Corps to field inspect the property site, if necessary, to help in the determination process. The Corps may also request a delineation of water resources on a property to be submitted. The printed form and supporting documents should be mailed to:

U.S. Army Corps of Engineers
Nashville District
3701 Bell Road
Nashville, TN 37214
Phone: (615) 389-7500

Property Owner Contact Information

Name: Sidney Brian
Address: 5800 One Perkins Pl. Ste. 6A
Baton Rouge, LA, 70808
Telephone: 225-766-1443
Fax: _____
Email: sbrian@trinitybusinessgroup.net

Owner Representative Contact Information

Name and Company: Frank Amatucci
Address: Barge Design Solutions, Inc.
615 3rd Avenue South, Suite 700
Nashville, TN 37210
Telephone: 615-252-4406
Fax: _____
Email: Frank.Amatucci@bargedesign.com

SUBJECT PROPERTY INFORMATION

Address: 7211 Centennial Boulevard
Nashville, Tennessee

County: Davidson State: TN

Lat/Long in Decimal Degrees: 36.181997° "N -86.878077° "W

Approximate size of property in acres: 5.5

The subject property is: (check as many as applicable)

cleared (if checked, how long?) UNK wooded pasture agricultural field

The water resources on the subject property include: (check as many as applicable)

Streams How many? 1 Estimated lengths 571 LF

Ponds How many? _____ Estimated acres _____

Wetlands How many? 2 Estimated acres 0.16 acres (cumulative)

Other Water Resources (ditches, swales, etc.) How many? 1

Is the property in an incorporated area? Yes or No

If it is in an incorporated area, please provide the name of the city/town _____

Is the property subject to a conservation easement or deed restriction? Yes or No

Was the property used as mitigation for a previously permitted project by the Corps? Yes or No

Is the property neighboring, adjacent to and/or bordering a project previously permitted by the Corps?
 Yes or No or Unknown

For the previous 3 questions, where answered Yes, please explain and provide the name of the project, permit number, permittee name, or permitted property address, if available:

MAPS: Please provide a map or plat (aerial photo, city or county map, soil survey photo, USGS Quad map, etc.) that accurately identifies the physical boundaries of the property. If the property is farmland, it may be necessary for you to contact the Natural Resources Conservation Service for a wetland delineation before you can request a jurisdictional determination.

If you are considering doing work on the property, please identify on a map or in a separate drawing the footprint, location, type of potential work, and water resources. This information will assist us in the determination process and reduce unnecessary delays of processing subsequent permits, if required.

OPTIONAL DOCUMENTATION: Photographs can greatly assist in the review process and often make a field visit unnecessary. We must see complete coverage of the property and/or the water resource in question, including the grass and trees.

If the property and/or the water resource in question are to be surveyed or delineated, we suggest waiting for the survey or delineation to be completed and include a copy with your request. Any other data you can include may help, such as land use or cropping history for the past five years, drainage improvements, etc.

PROCEDURE: We will review all available data within our office and attempt to provide a quick, accurate response to your request. Many determinations require a field site visit, which always takes more time to complete.

Signature of Owner

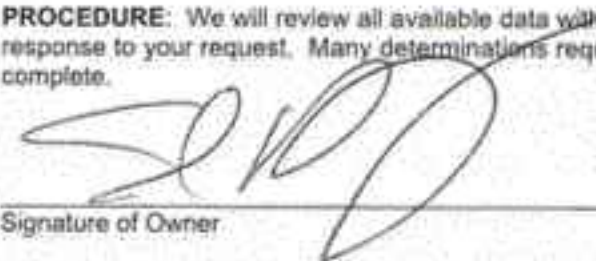

Date

11/15/22

Disclaimer: The information requirement for a jurisdictional determination as presented in this form is not an exhaustive list. The U.S. Army Corps of Engineers may request additional information not described in this request form.

APPENDIX B - FIGURES

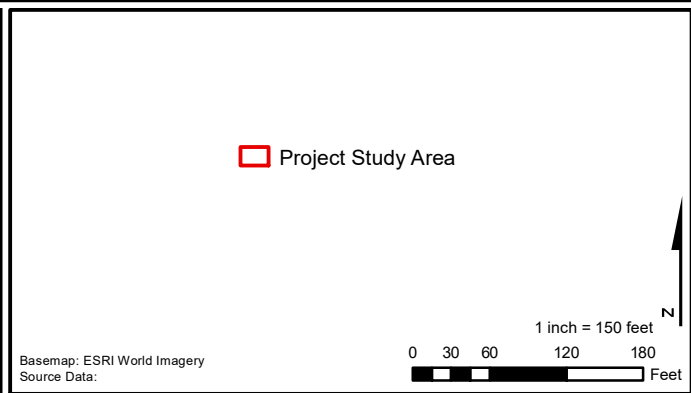
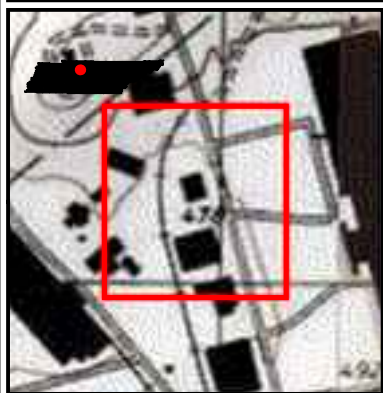

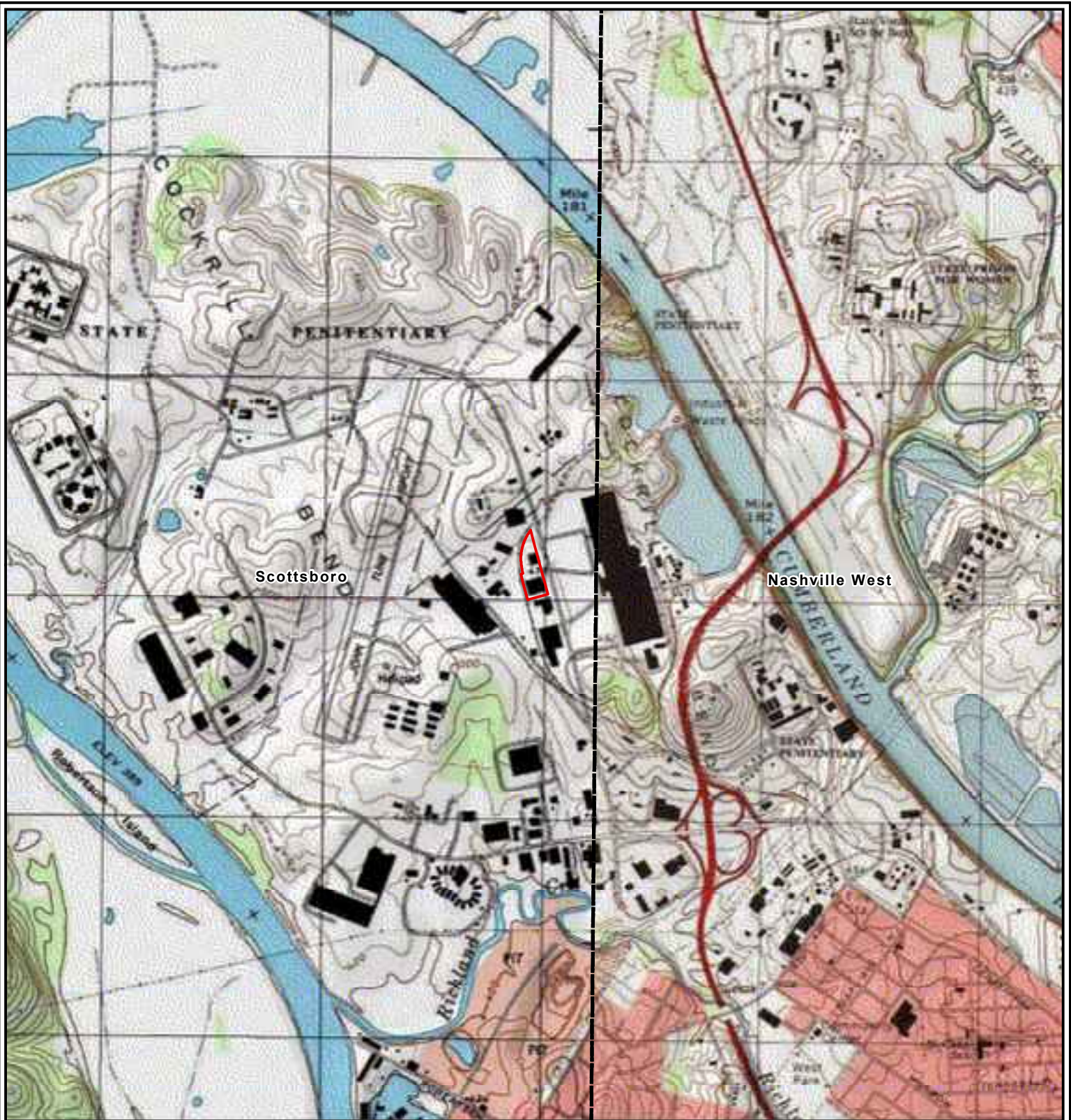

PROJECT: Trinity Business Group, LLC Triune Residuals Management Project Nashville, Davidson County, Tennessee	
TITLE: AERIAL SITE LOCATION MAP	
PROJ NO: 3712202	FIGURE 1
DATE: October 2022	
615 3rd Avenue South, Suite 700 Nashville, TN 37210	



SCOTTSBORO 7.5 MINUTE QUADRANGLE



-  Project Study Area
-  USGS 24k Topo Map Boundary

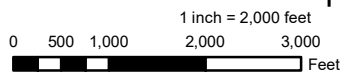

Basemap: ESRI USA Topo Map
Source Data: ESRI 24K Boundaries

PROJECT: Trinity Business Group, LLC
Triune Residuals Management Project
Nashville, Davidson County, Tennessee

TITLE: **USGS SITE LOCATION MAP**

PROJ NO: 3712202
DATE: October 2022

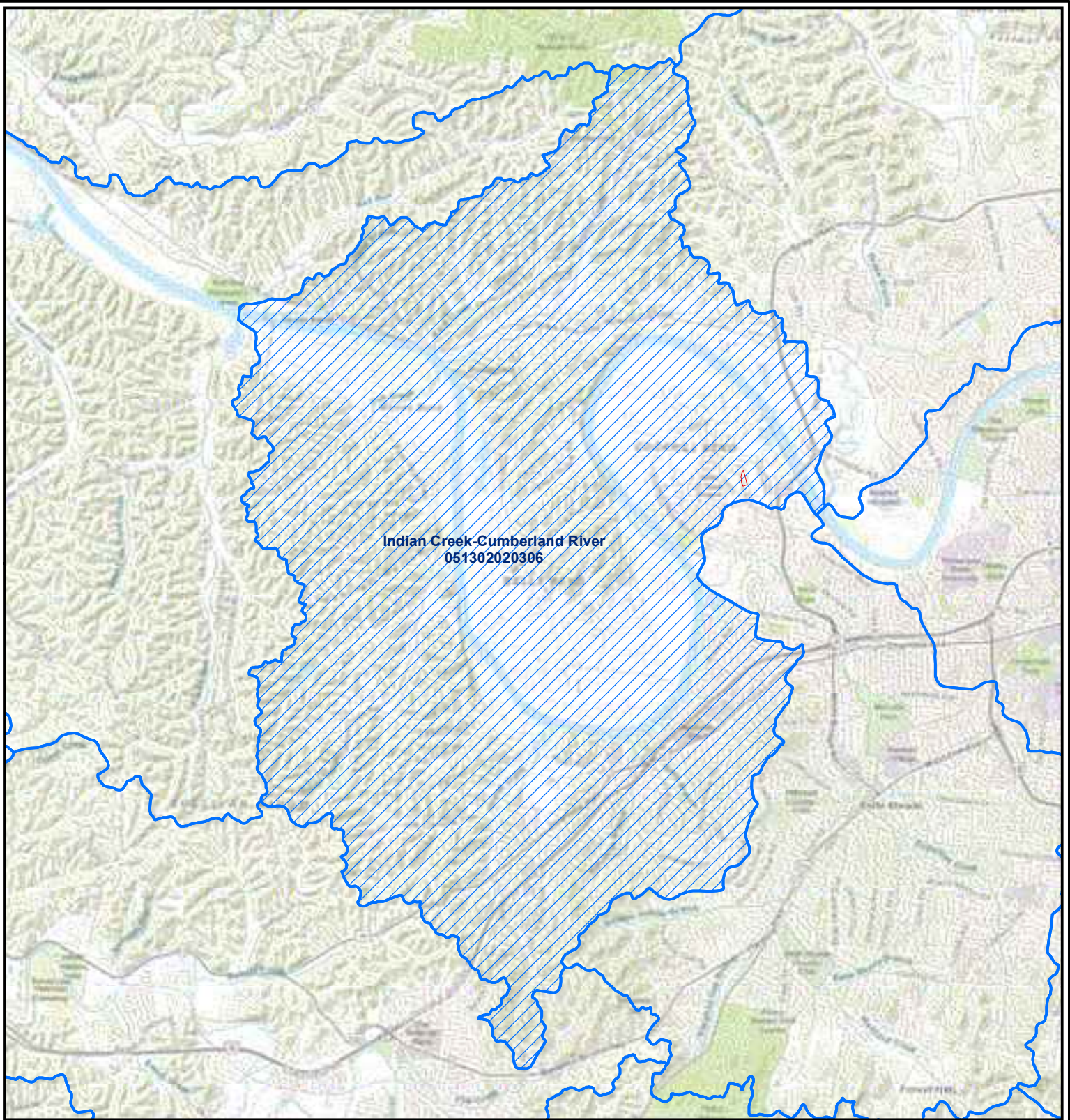

FIGURE 2

BARGE
615 3rd Avenue South, Suite 700
Nashville, TN 37210



Indian Creek-Cumberland River
051302020306



-  Project Watershed
-  HUC 12 Watershed
-  Project Study Area

PROJECT: Trinity Business Group, LLC
Triune Residuals Management Project
Nashville, Davidson County, Tennessee

TITLE: **PROJECT WATERSHED MAP**

PROJ NO: 3712202

FIGURE 3

DATE: October 2022

BARGE
615 3rd Avenue South, Suite 700
Nashville, TN 37210

1 inch = 2 miles



Basemap: ESRI USA Topo Map
Source Data: ESRI 24K Boundaries

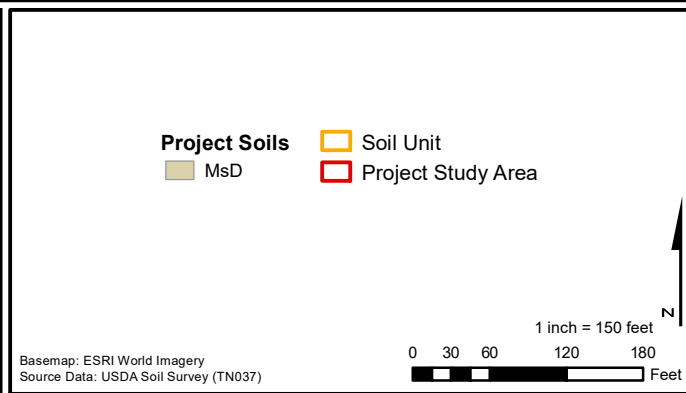
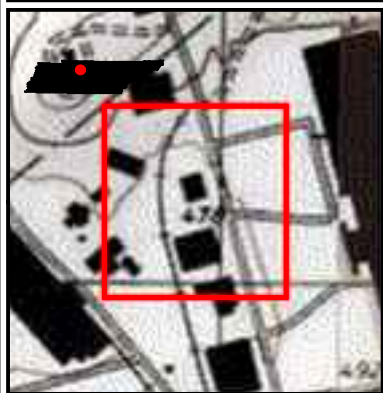

PROJECT: Trinity Business Group, LLC Triune Residuals Management Project Nashville, Davidson County, Tennessee	
TITLE: PROJECT SOIL UNIT MAP	
PROJ NO: 3712202	FIGURE 4
DATE: October 2022	
 615 3rd Avenue South, Suite 700 Nashville, TN 37210	

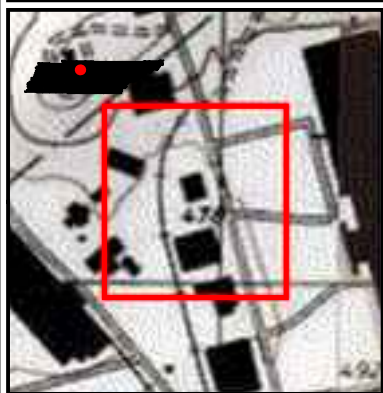

NWI Wetland

Wetland Type

- Freshwater Emergent Wetland
- Freshwater Forested/Shrub Wetland
- Freshwater Pond
- Lake
- Riverine

Project Study Area

1 inch = 150 feet

0 30 60 120 180 Feet

Baseemap: ESRI World Imagery
Source Data: USFWS NWI (TN); USGS NHD Flowline (TN)

PROJECT: Trinity Business Group, LLC Triune Residuals Management Project Nashville, Davidson County, Tennessee	
TITLE: NATIONAL WETLAND INVENTORY MAP	
PROJ NO: 3712202	FIGURE 5
DATE: October 2022	
 615 3rd Avenue South, Suite 700 Nashville, TN 37210	

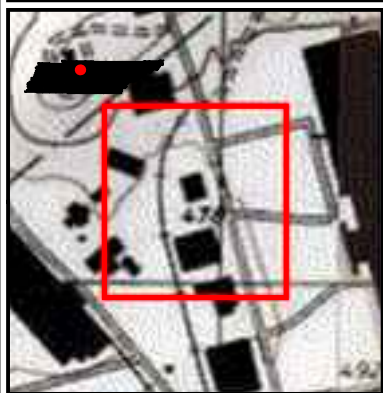
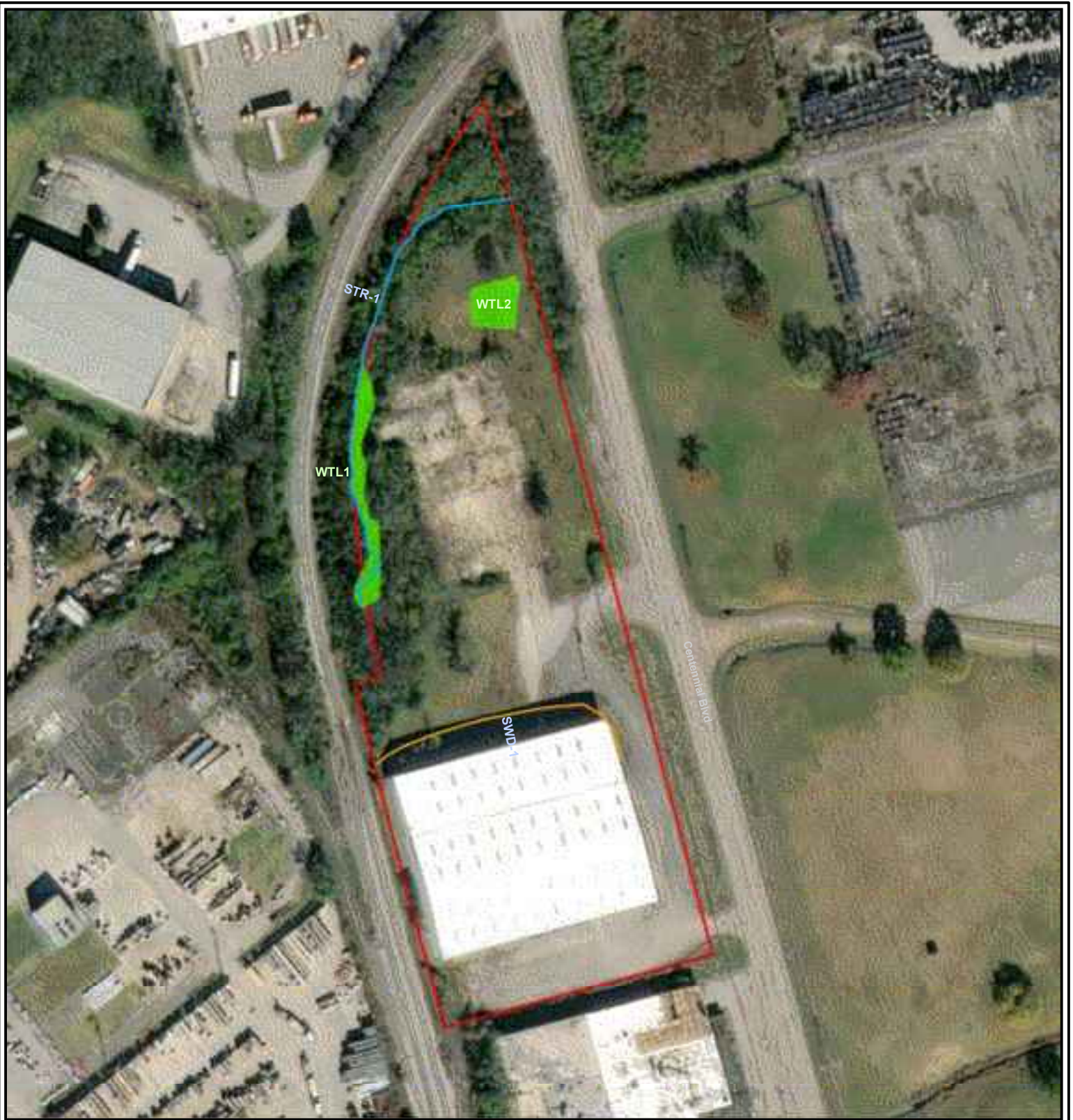

— Delineated Intermittent Stream Project Study Area
— Stormwater Drainage Swale
 Delineated Wetland

1 inch = 150 feet

0 30 60 120 180
 Feet

N

Basemap: ESRI World Imagery
 Source Data: Barge Survey 2022-08-11

PROJECT:
 Trinity Business Group, LLC
 Triune Residuals Management Project
 Nashville, Davidson County, Tennessee

TITLE:
EXISTING CONDITIONS MAP

PROJ NO: 3712202	FIGURE 6
DATE: October 2022	

615 3rd Avenue South, Suite 700
 Nashville, TN 37210

APPENDIX C – NON-WETLAND FEATURES AND WETLANDS TABLES

Table 1 – Non-Wetland Features within the Project study area

Waterbody I.D.	Description	Location Within Project Boundaries	Linear Feet within Project	AJD Score	Federal Jurisdictional Status	State Jurisdictional Status
STR-1	Intermittent Stream	Start: 36.183269, -86.878227 End: 36.182013, -86.878801	571	22.0	Yes	Yes
SWD-1	Stormwater Drainage Swale	Start: 36.181543, -86.877803 End: 36.181507, -86.878744	323	--	No	No

1: Federal jurisdiction status determined by observable connection to RPW and NonRPW WOTUS or significant nexus

Table 2 – Wetlands within the Project study area

Waterbody I.D.	Description	Location Within Project Boundaries	Acreage within Project	Federal Jurisdictional Status	State Jurisdictional Status
WTL-1	PFO	36.182067, -86.878757	0.10	Yes ¹	Yes
WTL-2	PEM	36.182911, -86.878281	0.06	No ¹	Yes

1: Federal jurisdiction status determined by observable connection to RPW and NonRPW WOTUS or significant nexus

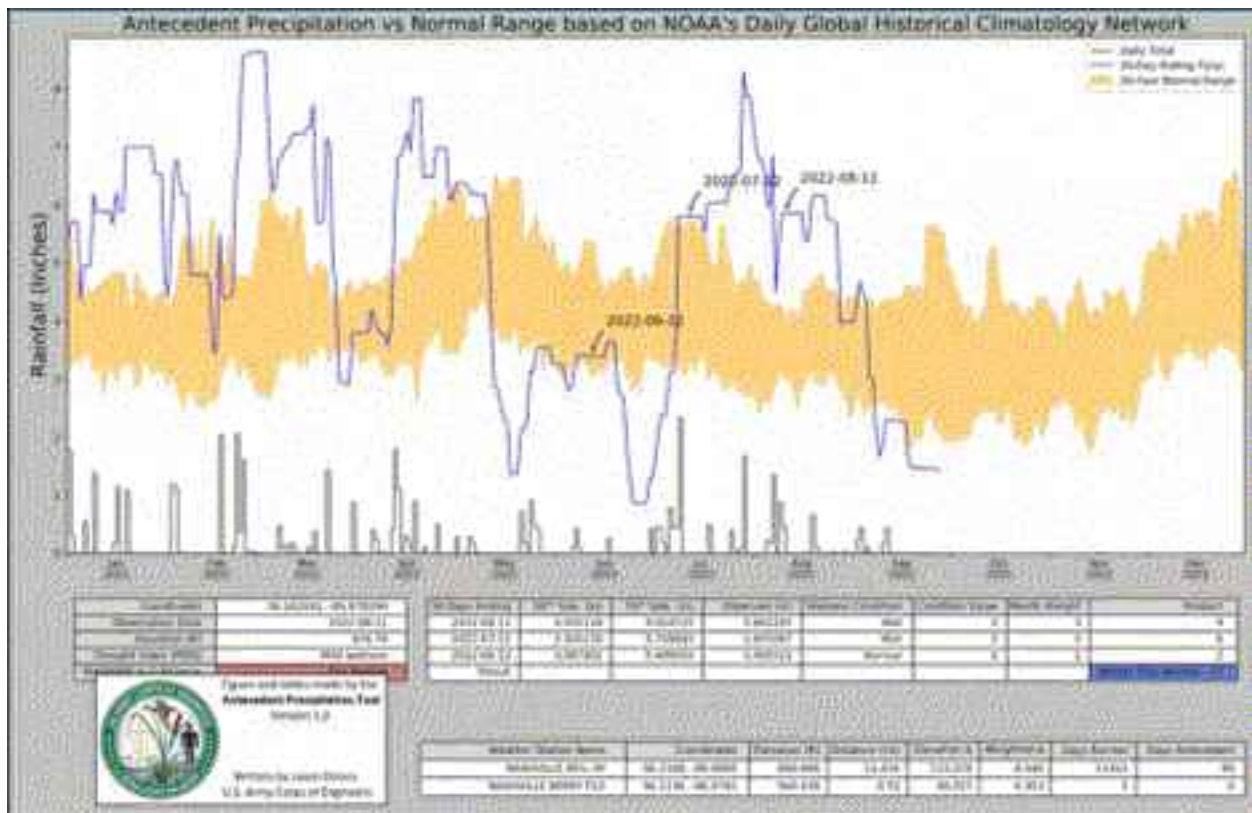

APPENDIX D - STREAM AND WETLAND DETERMINATION DATA FORMS

Hydrologic Determination Field Data Sheet

Tennessee Division of Water Pollution Control, Version 1.5

Named Waterbody: STR-1		Date/Time: 08/11/22 09:30
Assessors/Affiliation: F. Amatucci (TN-QHP #1203-TN21)		Project ID : 3712202
Site Name/Description: TBG 7211 Centennial Blvd Site		
Site Location: Nashville, Davidson County, Tennessee		
HUC (12 digit): Indian Creek-Cumberland River (051302020306)		Lat/Long: Start: 36.183269, -86.878227 End: 36.182013, -86.878801
Previous Rainfall (7-days) : 0.83 inches (CoCoRaHS STA# TN-DV-138)		
Precipitation this Season vs. Normal : abnormally wet <input type="checkbox"/> elevated <input checked="" type="checkbox"/> average <input type="checkbox"/> low <input type="checkbox"/> abnormally dry <input type="checkbox"/> unknown <input type="checkbox"/> Source of recent & seasonal precip data : <input type="checkbox"/>		
Watershed Size : 0.10 sqmi (StreamStats)	County: Davidson	
Soil Type(s) / Geology : MsD		Source: NRCS
Surrounding Land Use : Commercial, fragmented woodland, industrial		
Degree of historical alteration to natural channel morphology & hydrology (circle one & describe fully in Notes) : Severe <input type="checkbox"/> Moderate <input checked="" type="checkbox"/> Slight <input type="checkbox"/> Absent <input type="checkbox"/>		

Primary Field Indicators Observed

Primary Indicators	NO	YES
1. Hydrologic feature exists solely due to a process discharge	<input checked="" type="checkbox"/>	WWC <input type="checkbox"/>
2. Defined bed and bank absent, vegetation composed of upland and FACU species	<input checked="" type="checkbox"/>	WWC <input type="checkbox"/>
3. Watercourse dry anytime during February through April 15th, under normal precipitation / groundwater conditions	<input checked="" type="checkbox"/>	WWC <input type="checkbox"/>
4. Daily flow and precipitation records showing feature only flows in direct response to rainfall	<input checked="" type="checkbox"/>	WWC <input type="checkbox"/>
5. Presence of multiple populations of obligate lotic organisms with ≥ 2 month aquatic phase	<input checked="" type="checkbox"/>	Stream <input type="checkbox"/>
6. Presence of fish (except <i>Gambusia</i>)	<input checked="" type="checkbox"/>	Stream <input type="checkbox"/>
7. Presence of naturally occurring ground water table connection	<input checked="" type="checkbox"/>	Stream <input type="checkbox"/>
8. Flowing water in channel and 7 days since last precip >0.1" in local watershed	<input checked="" type="checkbox"/>	Stream <input type="checkbox"/>
9. Evidence watercourse has been used as a supply of drinking water	<input checked="" type="checkbox"/>	Stream <input type="checkbox"/>

NOTE: If any Primary Indicators 1-9 = "Yes", then no further investigation is necessary. However, assessors may choose to score secondary indicators as supporting evidence.

In the absence of a primary indicator, or other definitive evidence, complete the secondary indicator table on page 2 of this sheet, and provide score below.

Guidance for the interpretation and scoring of both the primary & secondary indicators is provided in *TDEC-WPC Guidance For Making Hydrologic Determinations, Version 1.5*

Overall Hydrologic Determination = STREAM

Secondary Indicator Score (if applicable) = 20.5

Justification / Notes :

Feature originates offsite from the east under Centennial Boulevard

Moderate presence of surface water observed in channel which flows south between railroad tracks and warehouse structure

Secondary Field Indicator Evaluation

A. Geomorphology (Subtotal = 8.50)	Absent	Weak	Moderate	Strong
1. Continuous bed and bank	0	1	2	3
2. Sinuous channel	0	1	2	3
3. In-channel structure: riffle-pool sequences	0	1	2	3
4. Sorting of soil textures or other substrate	0	1	2	3
5. Active/relic floodplain	0	0.5	2	1.5
6. Depositional bars or benches	0	1	2	3
7. Braided channel	0	1	2	3
8. Recent alluvial deposits	0	0.5	1	1.5
9. Natural levees	0	1	2	3
10. Headcuts	0	1	2	3
11. Grade controls	0	0.5	2	1.5
12. Natural valley or drainageway	0	0.5	1	1.5
13. At least second order channel on existing USGS or NRCS map	No = 0 <input checked="" type="checkbox"/>		Yes = 3 <input type="checkbox"/>	

B. Hydrology (Subtotal = 5.00)	Absent	Weak	Moderate	Strong
14. Subsurface flow/discharge into channel	0	1	2	3
15. Water in channel and >48 hours since sig. rain	0	1	2	3
16. Leaf litter in channel (January – September)	1.5	1	0.5	0
17. Sediment on plants or on debris	0	0.5	1	1.5
18. Organic debris lines or piles (wrack lines)	0	0.5	1	1.5
19. Hydric soils in channel bed or sides of channel	No = 0 <input checked="" type="checkbox"/>		Yes = 1.5 <input type="checkbox"/>	

C. Biology (Subtotal = 7.00)	Absent	Weak	Moderate	Strong
20. Fibrous roots in channel bed ¹	3	2	1	0
21. Rooted plants in the thalweg ¹	3	2	1	0
22. Crayfish in stream (exclude in floodplain)	0	1	2	3
23. Bivalves/mussels	0	1	2	3
24. Amphibians	0	0.5	1	1.5
25. Macroinvertebrates (record type & abundance)	0	1	2	3
26. Filamentous algae; periphyton	0	1	2	3
27. Iron oxidizing bacteria/fungus	0	0.5	1	1.5
28. Wetland plants in channel bed ²	0	0.5	1	1.5

¹ Focus is on the presence of **terrestrial** plants.

² Focus is on the presence of aquatic or wetland plants.

Total Points = 20.5

Under Normal Conditions, Watercourse is a Wet Weather Conveyance if Secondary Indicator Score < 19 points

Notes :

Bed and bank is moderately present in the upper reach but begins to fade further downslope

As bed and bank begin to weaken the floodplain for the feature strengthens

Some sorting present, as well as alluvial deposits, but the channel is bedrock lined, which occasion was grade controls

No terrestrial vegetation in the channel, but some green ash saplings were in the lower reach.

Isopods and Lymnaeidae (lunged) snails observed within the flowing waters of the reach.

Surface water was nearly throughout the OHWM width of the channel

There was no leaf litter in the channel, but some presence of wracklines was observed.

Project/Site: TBG 7211 Centennial Blvd Site City/County: Nashville / Davidson Sampling Date: 08/11/22
 Applicant/Owner: Barge Design Solutions State: TN Sampling Point: WTL-1
 Investigator(s): FCA Section, Township, Range: _____
 Landform (hillside, terrace, etc.): Floodplain Local relief (concave, convex, none): Concave Slope (%): 1-2
 Subregion (LRR or MLRA): LRR N, MLRA 123 Lat: 36.182067, Long: -86.878757 Datum: Nad83
 Soil Map Unit Name: MsD NWI classification: --

Are climatic / hydrologic conditions on the site typical for this time of year? Yes X No _____ (If no, explain in Remarks.)
 Are Vegetation _____, Soil _____, or Hydrology _____ significantly disturbed? Are "Normal Circumstances" present? Yes X No _____
 Are Vegetation _____, Soil _____, or Hydrology _____ naturally problematic? (If needed, explain any answers in Remarks.)

SUMMARY OF FINDINGS – Attach site map showing sampling point locations, transects, important features, etc.

Hydrophytic Vegetation Present? Yes <u>X</u> No _____ Hydric Soil Present? Yes <u>X</u> No _____ Wetland Hydrology Present? Yes <u>X</u> No _____	Is the Sampled Area within a Wetland? Yes <u>X</u> No _____
Remarks:	

HYDROLOGY

Wetland Hydrology Indicators: <u>Primary Indicators</u> (minimum of one is required; check all that apply)	<u>Secondary Indicators</u> (minimum of two required)
_____ Surface Water (A1) <u>X</u> High Water Table (A2) <u>X</u> Saturation (A3) _____ Water Marks (B1) _____ Sediment Deposits (B2) _____ Drift Deposits (B3) _____ Algal Mat or Crust (B4) _____ Iron Deposits (B5) _____ Inundation Visible on Aerial Imagery (B7) <u>X</u> Water-Stained Leaves (B9) _____ Aquatic Fauna (B13)	_____ True Aquatic Plants (B14) _____ Hydrogen Sulfide Odor (C1) _____ Oxidized Rhizospheres on Living Roots (C3) _____ Presence of Reduced Iron (C4) _____ Recent Iron Reduction in Tilled Soils (C6) _____ Thin Muck Surface (C7) _____ Other (Explain in Remarks)
_____ Surface Soil Cracks (B6) _____ Sparsely Vegetated Concave Surface (B8) <u>X</u> Drainage Patterns (B10) _____ Moss Trim Lines (B16) _____ Dry-Season Water Table (C2) _____ Crayfish Burrows (C8) _____ Saturation Visible on Aerial Imagery (C9) _____ Stunted or Stressed Plants (D1) <u>X</u> Geomorphic Position (D2) _____ Shallow Aquitard (D3) _____ Microtopographic Relief (D4) <u>X</u> FAC-Neutral Test (D5)	

Field Observations: Surface Water Present? Yes _____ No _____ Depth (inches): _____ Water Table Present? Yes <u>X</u> No _____ Depth (inches): <u>6</u> Saturation Present? Yes <u>X</u> No _____ Depth (inches): <u>1</u> (includes capillary fringe)	Wetland Hydrology Present? Yes <u>X</u> No _____
---	---

Describe Recorded Data (stream gauge, monitoring well, aerial photos, previous inspections), if available:

Remarks:

VEGETATION (Four Strata) – Use scientific names of plants.

Sampling Point: WTL-1

Tree Stratum (Plot size: <u>30 ft</u>)	Absolute % Cover	Dominant Species?	Indicator Status
1. <u>Fraxinus pennsylvanica</u>	<u>60</u>	<u>Yes</u>	<u>FACW</u>
2. <u>Acer negundo</u>	<u>25</u>	<u>Yes</u>	<u>FAC</u>
3. _____	_____	_____	_____
4. _____	_____	_____	_____
5. _____	_____	_____	_____
6. _____	_____	_____	_____
7. _____	_____	_____	_____
	<u>85</u> =Total Cover		
	50% of total cover: <u>43</u>	20% of total cover: <u>17</u>	

Sapling/Shrub Stratum (Plot size: <u>15ft</u>)	Absolute % Cover	Dominant Species?	Indicator Status
1. <u>Fraxinus pennsylvanica</u>	<u>35</u>	<u>Yes</u>	<u>FACW</u>
2. _____	_____	_____	_____
3. _____	_____	_____	_____
4. _____	_____	_____	_____
5. _____	_____	_____	_____
6. _____	_____	_____	_____
7. _____	_____	_____	_____
8. _____	_____	_____	_____
9. _____	_____	_____	_____
	<u>35</u> =Total Cover		
	50% of total cover: <u>18</u>	20% of total cover: <u>7</u>	

Herb Stratum (Plot size: <u>5ft</u>)	Absolute % Cover	Dominant Species?	Indicator Status
1. <u>Glyceria striata</u>	<u>45</u>	<u>Yes</u>	<u>OBL</u>
2. <u>Fraxinus pennsylvanica</u>	<u>15</u>	<u>Yes</u>	<u>FACW</u>
3. <u>Pilea pumila</u>	<u>15</u>	<u>Yes</u>	<u>FACW</u>
4. _____	_____	_____	_____
5. _____	_____	_____	_____
6. _____	_____	_____	_____
7. _____	_____	_____	_____
8. _____	_____	_____	_____
9. _____	_____	_____	_____
10. _____	_____	_____	_____
11. _____	_____	_____	_____
	<u>75</u> =Total Cover		
	50% of total cover: <u>38</u>	20% of total cover: <u>15</u>	

Woody Vine Stratum (Plot size: <u>15ft</u>)	Absolute % Cover	Dominant Species?	Indicator Status
1. _____	_____	_____	_____
2. _____	_____	_____	_____
3. _____	_____	_____	_____
4. _____	_____	_____	_____
5. _____	_____	_____	_____
	_____ =Total Cover		
	50% of total cover: _____	20% of total cover: _____	

Dominance Test worksheet:

Number of Dominant Species That Are OBL, FACW, or FAC: 6 (A)

Total Number of Dominant Species Across All Strata: 6 (B)

Percent of Dominant Species That Are OBL, FACW, or FAC: 100.0% (A/B)

Prevalence Index worksheet:

Total % Cover of:	Multiply by:
OBL species <u>45</u>	x 1 = <u>45</u>
FACW species <u>125</u>	x 2 = <u>250</u>
FAC species <u>25</u>	x 3 = <u>75</u>
FACU species <u>0</u>	x 4 = <u>0</u>
UPL species <u>0</u>	x 5 = <u>0</u>
Column Totals: <u>195</u> (A)	<u>370</u> (B)
Prevalence Index = B/A = <u>1.90</u>	

Hydrophytic Vegetation Indicators:

 1 - Rapid Test for Hydrophytic Vegetation

X 2 - Dominance Test is >50%

X 3 - Prevalence Index is ≤3.0¹

 4 - Morphological Adaptations¹ (Provide supporting data in Remarks or on a separate sheet)

 Problematic Hydrophytic Vegetation¹ (Explain)

¹Indicators of hydric soil and wetland hydrology must be present, unless disturbed or problematic.

Definitions of Four Vegetation Strata:

Tree – Woody plants, excluding vines, 3 in. (7.6 cm) or more in diameter at breast height (DBH), regardless of height.

Sapling/Shrub – Woody plants, excluding vines, less than 3 in. DBH and greater than or equal to 3.28 ft (1 m) tall.

Herb – All herbaceous (non-woody) plants, regardless of size, and woody plants less than 3.28 ft tall.

Woody Vine – All woody vines greater than 3.28 ft in height.

Hydrophytic Vegetation Present? Yes X No _____

Remarks: (Include photo numbers here or on a separate sheet.)

SOIL

Sampling Point: WTL-1

Profile Description: (Describe to the depth needed to document the indicator or confirm the absence of indicators.)								
Depth (inches)	Matrix		Redox Features				Texture	Remarks
	Color (moist)	%	Color (moist)	%	Type ¹	Loc ²		
0-3	10YR 3/2	100					Loamy/Clayey	
3-18	10YR 4/2	75	10YR 5/6	25	C	M	Loamy/Clayey	Prominent redox concentrations

¹Type: C=Concentration, D=Depletion, RM=Reduced Matrix, MS=Masked Sand Grains.

²Location: PL=Pore Lining, M=Matrix.

Hydric Soil Indicators:

- Histosol (A1)
- Histic Epipedon (A2)
- Black Histic (A3)
- Hydrogen Sulfide (A4)
- Stratified Layers (A5)
- 2 cm Muck (A10) **(LRR N)**
- Depleted Below Dark Surface (A11)
- Thick Dark Surface (A12)
- Sandy Mucky Mineral (S1)
- Sandy Gleyed Matrix (S4)
- Sandy Redox (S5)
- Stripped Matrix (S6)
- Dark Surface (S7)

- Polyvalue Below Surface (S8) **(MLRA 147, 148)**
- Thin Dark Surface (S9) **(MLRA 147, 148)**
- Loamy Mucky Mineral (F1) **(MLRA 136)**
- Loamy Gleyed Matrix (F2)
- Depleted Matrix (F3)
- Redox Dark Surface (F6)
- Depleted Dark Surface (F7)
- Redox Depressions (F8)
- Iron-Manganese Masses (F12) **(LRR N, MLRA 136)**
- Umbric Surface (F13) **(MLRA 122, 136)**
- Piedmont Floodplain Soils (F19) **(MLRA 148)**
- Red Parent Material (F21) **(MLRA 127, 147, 148)**

Indicators for Problematic Hydric Soils³:

- 2 cm Muck (A10) **(MLRA 147)**
- Coast Prairie Redox (A16) **(MLRA 147, 148)**
- Piedmont Floodplain Soils (F19) **(MLRA 136, 147)**
- Red Parent Material (F21) **(outside MLRA 127, 147, 148)**
- Very Shallow Dark Surface (F22)
- Other (Explain in Remarks)

³Indicators of hydrophytic vegetation and wetland hydrology must be present, unless disturbed or problematic.

Restrictive Layer (if observed):

Type: _____
 Depth (inches): _____

Hydric Soil Present? Yes No

Remarks:

Project/Site: TBG 7211 Centennial Blvd Site City/County: Nashville / Davidson Sampling Date: 08/11/22
 Applicant/Owner: Barge Design Solutions State: TN Sampling Point: WTL-2
 Investigator(s): FCA Section, Township, Range: _____
 Landform (hillside, terrace, etc.): Depression Local relief (concave, convex, none): Concave Slope (%): 0-1
 Subregion (LRR or MLRA): LRR N, MLRA 123 Lat: 36.182911, Long: -86.878281 Datum: Nad83
 Soil Map Unit Name: MsD NWI classification: --

Are climatic / hydrologic conditions on the site typical for this time of year? Yes X No _____ (If no, explain in Remarks.)
 Are Vegetation _____, Soil _____, or Hydrology _____ significantly disturbed? Are "Normal Circumstances" present? Yes X No _____
 Are Vegetation _____, Soil _____, or Hydrology _____ naturally problematic? (If needed, explain any answers in Remarks.)

SUMMARY OF FINDINGS – Attach site map showing sampling point locations, transects, important features, etc.

Hydrophytic Vegetation Present? Yes <u>X</u> No _____ Hydric Soil Present? Yes <u>X</u> No _____ Wetland Hydrology Present? Yes <u>X</u> No _____	Is the Sampled Area within a Wetland? Yes <u>X</u> No _____
Remarks:	

HYDROLOGY

Wetland Hydrology Indicators: <u>Primary Indicators</u> (minimum of one is required; check all that apply)	<u>Secondary Indicators</u> (minimum of two required)
<input type="checkbox"/> Surface Water (A1) <input type="checkbox"/> True Aquatic Plants (B14) <input type="checkbox"/> High Water Table (A2) <input type="checkbox"/> Hydrogen Sulfide Odor (C1) <input checked="" type="checkbox"/> Saturation (A3) <input type="checkbox"/> Oxidized Rhizospheres on Living Roots (C3) <input type="checkbox"/> Water Marks (B1) <input type="checkbox"/> Presence of Reduced Iron (C4) <input type="checkbox"/> Sediment Deposits (B2) <input type="checkbox"/> Recent Iron Reduction in Tilled Soils (C6) <input type="checkbox"/> Drift Deposits (B3) <input type="checkbox"/> Thin Muck Surface (C7) <input type="checkbox"/> Algal Mat or Crust (B4) <input type="checkbox"/> Other (Explain in Remarks) <input type="checkbox"/> Iron Deposits (B5) <input type="checkbox"/> Inundation Visible on Aerial Imagery (B7) <input checked="" type="checkbox"/> Water-Stained Leaves (B9) <input type="checkbox"/> Aquatic Fauna (B13)	<input type="checkbox"/> Surface Soil Cracks (B6) <input type="checkbox"/> Sparsely Vegetated Concave Surface (B8) <input type="checkbox"/> Drainage Patterns (B10) <input type="checkbox"/> Moss Trim Lines (B16) <input type="checkbox"/> Dry-Season Water Table (C2) <input type="checkbox"/> Crayfish Burrows (C8) <input type="checkbox"/> Saturation Visible on Aerial Imagery (C9) <input type="checkbox"/> Stunted or Stressed Plants (D1) <input type="checkbox"/> Geomorphic Position (D2) <input checked="" type="checkbox"/> Shallow Aquitard (D3) <input checked="" type="checkbox"/> Microtopographic Relief (D4) <input checked="" type="checkbox"/> FAC-Neutral Test (D5)

Field Observations: Surface Water Present? Yes _____ No <u>X</u> Depth (inches): _____ Water Table Present? Yes _____ No <u>X</u> Depth (inches): _____ Saturation Present? Yes <u>X</u> No _____ Depth (inches): <u>2</u> (includes capillary fringe)	Wetland Hydrology Present? Yes <u>X</u> No _____
---	---

Describe Recorded Data (stream gauge, monitoring well, aerial photos, previous inspections), if available:

Remarks:

VEGETATION (Four Strata) – Use scientific names of plants.

Sampling Point: WTL-2

Tree Stratum (Plot size: <u>30 ft</u>)	Absolute % Cover	Dominant Species?	Indicator Status
1. _____	_____	_____	_____
2. _____	_____	_____	_____
3. _____	_____	_____	_____
4. _____	_____	_____	_____
5. _____	_____	_____	_____
6. _____	_____	_____	_____
7. _____	_____	_____	_____
_____ = Total Cover			
50% of total cover: _____ 20% of total cover: _____			

Sapling/Shrub Stratum (Plot size: <u>15ft</u>)	Absolute % Cover	Dominant Species?	Indicator Status
1. _____	_____	_____	_____
2. _____	_____	_____	_____
3. _____	_____	_____	_____
4. _____	_____	_____	_____
5. _____	_____	_____	_____
6. _____	_____	_____	_____
7. _____	_____	_____	_____
8. _____	_____	_____	_____
9. _____	_____	_____	_____
_____ = Total Cover			
50% of total cover: _____ 20% of total cover: _____			

Herb Stratum (Plot size: <u>5ft</u>)	Absolute % Cover	Dominant Species?	Indicator Status
1. <u>Carex vulpinoidea</u>	<u>35</u>	<u>Yes</u>	<u>OBL</u>
2. <u>Cyperus esculentus</u>	<u>30</u>	<u>Yes</u>	<u>FACW</u>
3. <u>Rumex crispus</u>	<u>15</u>	<u>No</u>	<u>FAC</u>
4. <u>Persicaria hydropiper</u>	<u>25</u>	<u>Yes</u>	<u>OBL</u>
5. _____	_____	_____	_____
6. _____	_____	_____	_____
7. _____	_____	_____	_____
8. _____	_____	_____	_____
9. _____	_____	_____	_____
10. _____	_____	_____	_____
11. _____	_____	_____	_____
_____ = Total Cover			
50% of total cover: <u>53</u> 20% of total cover: <u>21</u>			

Woody Vine Stratum (Plot size: <u>15ft</u>)	Absolute % Cover	Dominant Species?	Indicator Status
1. _____	_____	_____	_____
2. _____	_____	_____	_____
3. _____	_____	_____	_____
4. _____	_____	_____	_____
5. _____	_____	_____	_____
_____ = Total Cover			
50% of total cover: _____ 20% of total cover: _____			

Dominance Test worksheet:

Number of Dominant Species That Are OBL, FACW, or FAC: 3 (A)

Total Number of Dominant Species Across All Strata: 3 (B)

Percent of Dominant Species That Are OBL, FACW, or FAC: 100.0% (A/B)

Prevalence Index worksheet:

Total % Cover of:	Multiply by:
OBL species <u>60</u>	x 1 = <u>60</u>
FACW species <u>30</u>	x 2 = <u>60</u>
FAC species <u>15</u>	x 3 = <u>45</u>
FACU species <u>0</u>	x 4 = <u>0</u>
UPL species <u>0</u>	x 5 = <u>0</u>
Column Totals: <u>105</u> (A)	<u>165</u> (B)
Prevalence Index = B/A = <u>1.57</u>	

Hydrophytic Vegetation Indicators:

 1 - Rapid Test for Hydrophytic Vegetation

X 2 - Dominance Test is >50%

X 3 - Prevalence Index is ≤3.0¹

 4 - Morphological Adaptations¹ (Provide supporting data in Remarks or on a separate sheet)

 Problematic Hydrophytic Vegetation¹ (Explain)

¹Indicators of hydric soil and wetland hydrology must be present, unless disturbed or problematic.

Definitions of Four Vegetation Strata:

Tree – Woody plants, excluding vines, 3 in. (7.6 cm) or more in diameter at breast height (DBH), regardless of height.

Sapling/Shrub – Woody plants, excluding vines, less than 3 in. DBH and greater than or equal to 3.28 ft (1 m) tall.

Herb – All herbaceous (non-woody) plants, regardless of size, and woody plants less than 3.28 ft tall.

Woody Vine – All woody vines greater than 3.28 ft in height.

Hydrophytic Vegetation Present? Yes X No

Remarks: (Include photo numbers here or on a separate sheet.)

SOIL

Sampling Point: WTL-2

Profile Description: (Describe to the depth needed to document the indicator or confirm the absence of indicators.)								
Depth (inches)	Matrix		Redox Features				Texture	Remarks
	Color (moist)	%	Color (moist)	%	Type ¹	Loc ²		
0-2	10YR 3/2	100					Loamy/Clayey	
2-4	10YR 5/1	100					Loamy/Clayey	

¹Type: C=Concentration, D=Depletion, RM=Reduced Matrix, MS=Masked Sand Grains.

²Location: PL=Pore Lining, M=Matrix.

Hydric Soil Indicators:

- Histosol (A1)
- Histic Epipedon (A2)
- Black Histic (A3)
- Hydrogen Sulfide (A4)
- Stratified Layers (A5)
- 2 cm Muck (A10) **(LRR N)**
- Depleted Below Dark Surface (A11)
- Thick Dark Surface (A12)
- Sandy Mucky Mineral (S1)
- Sandy Gleyed Matrix (S4)
- Sandy Redox (S5)
- Stripped Matrix (S6)
- Dark Surface (S7)

- Polyvalue Below Surface (S8) **(MLRA 147, 148)**
- Thin Dark Surface (S9) **(MLRA 147, 148)**
- Loamy Mucky Mineral (F1) **(MLRA 136)**
- Loamy Gleyed Matrix (F2)
- Depleted Matrix (F3)
- Redox Dark Surface (F6)
- Depleted Dark Surface (F7)
- Redox Depressions (F8)
- Iron-Manganese Masses (F12) **(LRR N, MLRA 136)**
- Umbric Surface (F13) **(MLRA 122, 136)**
- Piedmont Floodplain Soils (F19) **(MLRA 148)**
- Red Parent Material (F21) **(MLRA 127, 147, 148)**

Indicators for Problematic Hydric Soils³:

- 2 cm Muck (A10) **(MLRA 147)**
- Coast Prairie Redox (A16) **(MLRA 147, 148)**
- Piedmont Floodplain Soils (F19) **(MLRA 136, 147)**
- Red Parent Material (F21) **(outside MLRA 127, 147, 148)**
- Very Shallow Dark Surface (F22)
- Other (Explain in Remarks)

³Indicators of hydrophytic vegetation and wetland hydrology must be present, unless disturbed or problematic.

Restrictive Layer (if observed):

Type: bedrock
 Depth (inches): 4

Hydric Soil Present? Yes No

Remarks:

Project/Site: TBG 7211 Centennial Blvd Site City/County: Nashville / Davidson Sampling Date: 08/11/22
 Applicant/Owner: Barge Design Solutions State: TN Sampling Point: UPL-1/2
 Investigator(s): FCA Section, Township, Range: _____
 Landform (hillside, terrace, etc.): Hillslope Local relief (concave, convex, none): Convex Slope (%): 1-3
 Subregion (LRR or MLRA): LRR N, MLRA 123 Lat: 36.182825 Long: -86.878661 Datum: Nad83
 Soil Map Unit Name: MsD NWI classification: --

Are climatic / hydrologic conditions on the site typical for this time of year? Yes X No _____ (If no, explain in Remarks.)
 Are Vegetation _____, Soil _____, or Hydrology _____ significantly disturbed? Are "Normal Circumstances" present? Yes X No _____
 Are Vegetation _____, Soil _____, or Hydrology _____ naturally problematic? (If needed, explain any answers in Remarks.)

SUMMARY OF FINDINGS – Attach site map showing sampling point locations, transects, important features, etc.

Hydrophytic Vegetation Present? Yes _____ No <u>X</u> Hydric Soil Present? Yes <u>X</u> No _____ Wetland Hydrology Present? Yes _____ No <u>X</u>	Is the Sampled Area within a Wetland? Yes _____ No <u>X</u>
Remarks:	

HYDROLOGY

Wetland Hydrology Indicators: <u>Primary Indicators (minimum of one is required; check all that apply)</u> ___ Surface Water (A1) ___ True Aquatic Plants (B14) ___ High Water Table (A2) ___ Hydrogen Sulfide Odor (C1) ___ Saturation (A3) ___ Oxidized Rhizospheres on Living Roots (C3) ___ Water Marks (B1) ___ Presence of Reduced Iron (C4) ___ Sediment Deposits (B2) ___ Recent Iron Reduction in Tilled Soils (C6) ___ Drift Deposits (B3) ___ Thin Muck Surface (C7) ___ Algal Mat or Crust (B4) ___ Other (Explain in Remarks) ___ Iron Deposits (B5) ___ Inundation Visible on Aerial Imagery (B7) ___ Water-Stained Leaves (B9) ___ Aquatic Fauna (B13)	<u>Secondary Indicators (minimum of two required)</u> ___ Surface Soil Cracks (B6) ___ Sparsely Vegetated Concave Surface (B8) ___ Drainage Patterns (B10) ___ Moss Trim Lines (B16) ___ Dry-Season Water Table (C2) ___ Crayfish Burrows (C8) ___ Saturation Visible on Aerial Imagery (C9) ___ Stunted or Stressed Plants (D1) ___ Geomorphic Position (D2) <u>X</u> Shallow Aquitard (D3) ___ Microtopographic Relief (D4) ___ FAC-Neutral Test (D5)
---	---

Field Observations: Surface Water Present? Yes _____ No <u>X</u> Depth (inches): _____ Water Table Present? Yes _____ No <u>X</u> Depth (inches): _____ Saturation Present? Yes _____ No <u>X</u> Depth (inches): _____ (includes capillary fringe)	Wetland Hydrology Present? Yes _____ No <u>X</u>
--	---

Describe Recorded Data (stream gauge, monitoring well, aerial photos, previous inspections), if available:

Remarks:

 No positive indicators of hydrology observed in the upland area

VEGETATION (Four Strata) – Use scientific names of plants.

Sampling Point: UPL-1/2

Tree Stratum (Plot size: <u>30 ft</u>)	Absolute % Cover	Dominant Species?	Indicator Status
1. _____	_____	_____	_____
2. _____	_____	_____	_____
3. _____	_____	_____	_____
4. _____	_____	_____	_____
5. _____	_____	_____	_____
6. _____	_____	_____	_____
7. _____	_____	_____	_____
	_____ = Total Cover		
50% of total cover: _____	20% of total cover: _____		

Sapling/Shrub Stratum (Plot size: <u>15ft</u>)	Absolute % Cover	Dominant Species?	Indicator Status
1. <u>Rubus argutus</u>	<u>45</u>	<u>Yes</u>	<u>FACU</u>
2. _____	_____	_____	_____
3. _____	_____	_____	_____
4. _____	_____	_____	_____
5. _____	_____	_____	_____
6. _____	_____	_____	_____
7. _____	_____	_____	_____
8. _____	_____	_____	_____
9. _____	_____	_____	_____
	<u>45</u> = Total Cover		
50% of total cover: <u>23</u>	20% of total cover: <u>9</u>		

Herb Stratum (Plot size: <u>5ft</u>)	Absolute % Cover	Dominant Species?	Indicator Status
1. <u>Verbesina occidentalis</u>	<u>25</u>	<u>Yes</u>	<u>FACU</u>
2. <u>Andropogon virginicus</u>	<u>25</u>	<u>Yes</u>	<u>FACU</u>
3. <u>Daucus carota</u>	<u>10</u>	<u>No</u>	<u>UPL</u>
4. <u>Plantago lanceolata</u>	<u>15</u>	<u>Yes</u>	<u>UPL</u>
5. _____	_____	_____	_____
6. _____	_____	_____	_____
7. _____	_____	_____	_____
8. _____	_____	_____	_____
9. _____	_____	_____	_____
10. _____	_____	_____	_____
11. _____	_____	_____	_____
	<u>75</u> = Total Cover		
50% of total cover: <u>38</u>	20% of total cover: <u>15</u>		

Woody Vine Stratum (Plot size: <u>15ft</u>)	Absolute % Cover	Dominant Species?	Indicator Status
1. _____	_____	_____	_____
2. _____	_____	_____	_____
3. _____	_____	_____	_____
4. _____	_____	_____	_____
5. _____	_____	_____	_____
	_____ = Total Cover		
50% of total cover: _____	20% of total cover: _____		

Dominance Test worksheet:

Number of Dominant Species That Are OBL, FACW, or FAC: 0 (A)

Total Number of Dominant Species Across All Strata: 4 (B)

Percent of Dominant Species That Are OBL, FACW, or FAC: 0.0% (A/B)

Prevalence Index worksheet:

Total % Cover of:	Multiply by:
OBL species <u>0</u>	x 1 = <u>0</u>
FACW species <u>0</u>	x 2 = <u>0</u>
FAC species <u>0</u>	x 3 = <u>0</u>
FACU species <u>95</u>	x 4 = <u>380</u>
UPL species <u>25</u>	x 5 = <u>125</u>
Column Totals: <u>120</u> (A)	<u>505</u> (B)
Prevalence Index = B/A = <u>4.21</u>	

Hydrophytic Vegetation Indicators:

 1 - Rapid Test for Hydrophytic Vegetation

 2 - Dominance Test is >50%

 3 - Prevalence Index is ≤3.0¹

 4 - Morphological Adaptations¹ (Provide supporting data in Remarks or on a separate sheet)

 Problematic Hydrophytic Vegetation¹ (Explain)

¹Indicators of hydric soil and wetland hydrology must be present, unless disturbed or problematic.

Definitions of Four Vegetation Strata:

Tree – Woody plants, excluding vines, 3 in. (7.6 cm) or more in diameter at breast height (DBH), regardless of height.

Sapling/Shrub – Woody plants, excluding vines, less than 3 in. DBH and greater than or equal to 3.28 ft (1 m) tall.

Herb – All herbaceous (non-woody) plants, regardless of size, and woody plants less than 3.28 ft tall.

Woody Vine – All woody vines greater than 3.28 ft in height.

Hydrophytic Vegetation Present? Yes No X

Remarks: (Include photo numbers here or on a separate sheet.)

SOIL

Sampling Point: UPL-1/2

Profile Description: (Describe to the depth needed to document the indicator or confirm the absence of indicators.)								
Depth (inches)	Matrix		Redox Features				Texture	Remarks
	Color (moist)	%	Color (moist)	%	Type ¹	Loc ²		
0-2	10YR 3/3	100					Loamy/Clayey	
2-5	10YR 5/4	100					Loamy/Clayey	

¹Type: C=Concentration, D=Depletion, RM=Reduced Matrix, MS=Masked Sand Grains.

²Location: PL=Pore Lining, M=Matrix.

Hydric Soil Indicators:

- Histosol (A1)
- Histic Epipedon (A2)
- Black Histic (A3)
- Hydrogen Sulfide (A4)
- Stratified Layers (A5)
- 2 cm Muck (A10) **(LRR N)**
- Depleted Below Dark Surface (A11)
- Thick Dark Surface (A12)
- Sandy Mucky Mineral (S1)
- Sandy Gleyed Matrix (S4)
- Sandy Redox (S5)
- Stripped Matrix (S6)
- Dark Surface (S7)

- Polyvalue Below Surface (S8) **(MLRA 147, 148)**
- Thin Dark Surface (S9) **(MLRA 147, 148)**
- Loamy Mucky Mineral (F1) **(MLRA 136)**
- Loamy Gleyed Matrix (F2)
- Depleted Matrix (F3)
- Redox Dark Surface (F6)
- Depleted Dark Surface (F7)
- Redox Depressions (F8)
- Iron-Manganese Masses (F12) **(LRR N, MLRA 136)**
- Umbric Surface (F13) **(MLRA 122, 136)**
- Piedmont Floodplain Soils (F19) **(MLRA 148)**
- Red Parent Material (F21) **(MLRA 127, 147, 148)**

Indicators for Problematic Hydric Soils³:

- 2 cm Muck (A10) **(MLRA 147)**
- Coast Prairie Redox (A16) **(MLRA 147, 148)**
- Piedmont Floodplain Soils (F19) **(MLRA 136, 147)**
- Red Parent Material (F21) **(outside MLRA 127, 147, 148)**
- Very Shallow Dark Surface (F22)
- Other (Explain in Remarks)

³Indicators of hydrophytic vegetation and wetland hydrology must be present, unless disturbed or problematic.

Restrictive Layer (if observed):

Type: _____ bedrock
 Depth (inches): _____ 5

Hydric Soil Present? Yes No

Remarks:

APPENDIX E - PHOTOGRAPHIC SUMMARY

Photo Summary

Summary of Environmental Features Nashville, Davidson County, Tennessee

Page 1 of 3



Photo: 1
By: F. Amatucci
Date: August 11, 2022
Feature: STR-1
Lat: 36.183201
Long: -86.878535

Representative conditions of STR-1 at the start of the reach.



Photo: 2
By: F. Amatucci
Date: August 11, 2022
Feature: STR-1
Lat: 36.182776
Long: -86.878785

Representative conditions of STR-1 before a slight loss of bed and bank within WTL-1.

Photo Summary

Summary of Environmental Features Nashville, Davidson County, Tennessee

Page 2 of 3



Photo: 3
By: F. Amatucci
Date: August 11, 2022
Feature: SWD-1
Lat: 36.181705
Long: -86.877865

Representative conditions of SWD-1 adjacent to the warehouse structure.



Photo: 4
By: F. Amatucci
Date: August 11, 2022
Feature: SWD-1
Lat: 36.181531
Long: -86.878712

Representative conditions of SWD-1 prior to flowing offsite behind the warehouse structure.

Photo Summary

Summary of Environmental Features Nashville, Davidson County, Tennessee

Page 3 of 3



Photo: 5
By: F. Amatucci
Date: August 11, 2022
Feature: WTL-1
Lat: 36.182088
Long: -86.878748

Representative conditions of WTL-1 serving as a floodplain for STR-1.

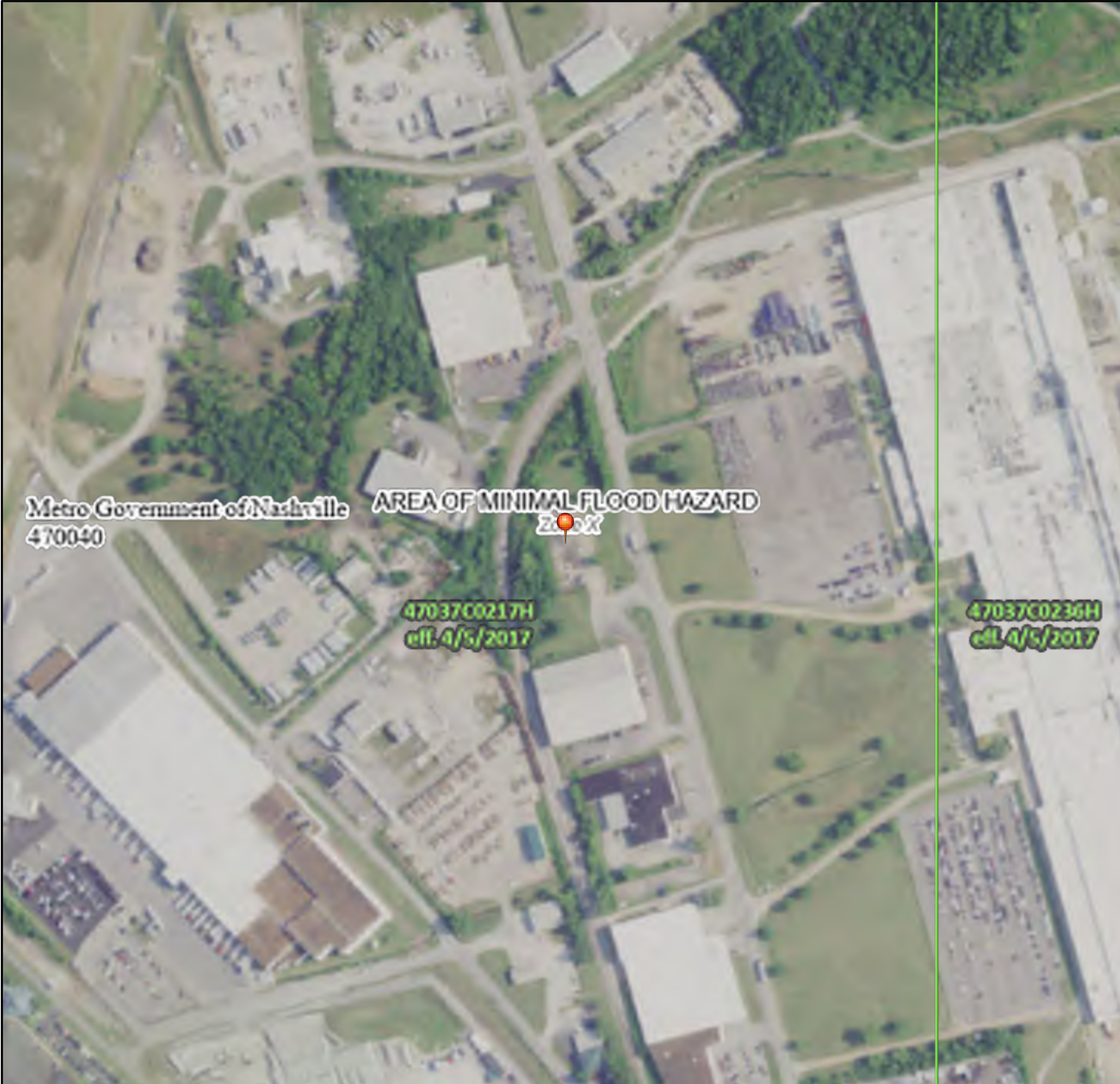

Photo: 6
By: F. Amatucci
Date: August 11, 2022
Feature: WTL-2
Lat: 36.182924
Long: -86.878282

Representative conditions of depressional wetland WTL-2.

**APPENDIX 5 –
FEMA Floodplain Map**

1:1



4) 6 8 9 10 11 12 13 14 15 16 17 18 19 20 21 22 23 24 25 26 27 28 29 30 31 32 33 34 35 36 37 38 39 40 41 42 43 44 45 46 47 48 49 50 51 52 53 54 55 56 57 58 59 60 61 62 63 64 65 66 67 68 69 70 71 72 73 74 75 76 77 78 79 80 81 82 83 84 85 86 87 88 89 90 91 92 93 94 95 96 97 98 99 100

68 \$ 2 68 \$ 6	L V H R W % D H J O R R G O H D V L R Q % = F Q H \$ 9 \$ L V W K % R U F S W K = F Q H \$ 9 \$ 9 \$ \$ H O D W R U J O R R G O
26 \$ 2 26 \$ 5	\$ O O D O & O O H J O R R G E P U G \$ U H V / R O O O O F O O F H I O R R G Z W K D H U D H G S W K O H W W K O O R Q H I R R W R U Z W K G U L O O D J H V / R O H W W K O O R Q H V T O U E O H F Q H ; X V X U H & R Q L W L R Q / \$ O O O & O O H J O R R G E P U G = F Q H ; \$ U H Z W K \$ G H G O R R G & L N G H W R H H H G H R V H V = F Q H ; \$ U H Z W K O R R G & L N G H W R H H H = F Q H ;
26 \$ 6 68 \$ 6	\$ U H R O Q L E O J O R R G E P U G = F Q H ; (I H F W L Y H V \$ U H R & G H W H U E Q G J O R R G E P U G = F Q H ; & O O O O & O Y H U W R U & V R U R & Z U H H H L N H R U J O R R G O O
26 \$ 6 68 \$ 6	& U R W & F W L R Q / Z W K \$ O O O O & O O H D V H U & U I O F H O H D V L R Q & F W D D T U D Q H F W % D H J O R R G O H D V L R Q L Q H % L E W R & V X G - X U L V L F W L R Q % & R Q E U A & F W D D T U D Q H F W % D H O L Q H & U R L O H % D H O L Q H & U R U D S L F J D V X U H
68 \$ 6	L L W D D W D \$ D L O D E O H R L L W D D W D \$ D L O D E O H & E S S G

7 K H S Q G L V S O D H G R Q W K H E S L V D Q D S S U R L B W H
S R L Q V V H O H F W H G E W K H X H U D O G G R H V Q R W U H S H
D Q D W K R U L W D W L Y H S U R S U W O R F D W L R Q

7 K L V E S F F S O L H V Z W K J V W D Q E U G / I R U W K H X H R
G L J W D D I O R R G E S / L I L W L V Q R W Y R L G D V G H F U L E G B O R Z
7 K H E D H E S V K R Q F F S O L H V Z W K J V E D H E S
D F X U D R W D Q E U G /

7 K H I O R R G K Q U G L Q R U B W L R Q L V G U L Y H G L U H F W O I U R W K H
D W K R U L W D W L Y H J Z E V H U L F H V S U R L G H G E J 7 K L V E S
Z V H S R U W H G R Q D V 3 D O G G R H V Q R W
U H O H F W F O O H V R U D P Q F Q W V V E H I X Q V W R W L V G D W H D O G
W L F I 7 K H J D O G H I I F W L Y H L Q R U B W L R Q B F O O H R U
E F F F V S H U V G G E Q Z G D V D R Y H U W L F I

7 K L V E S L B H L V Y R L G L I W K H R Q R U R U H R W K H I R O O R Z Q J E S
H O H P Q W V G R Q R W D S S D U E D H E S L B H U I O R R G F Q H O D E H V
O H F Q G V R O D H E D U E S F U H D W L R Q G D W H F F Q L W L G Q W L L I L H V
) S S O O H Q E H U D O G) & H I F W L Y H G D W H D S L B H V I R U
X E S S G D O G X R G U Q J G D U H V F O O R W E H X V G I R U
U H K O D W R U S U S R V H

**APPENDIX 6 –
IaPC Report**

IPaC resource list

This report is an automatically generated list of species and other resources such as critical habitat (collectively referred to as *trust resources*) under the U.S. Fish and Wildlife Service's (USFWS) jurisdiction that are known or expected to be on or near the project area referenced below. The list may also include trust resources that occur outside of the project area, but that could potentially be directly or indirectly affected by activities in the project area. However, determining the likelihood and extent of effects a project may have on trust resources typically requires gathering additional site-specific (e.g., vegetation/species surveys) and project-specific (e.g., magnitude and timing of proposed activities) information.

Below is a summary of the project information you provided and contact information for the USFWS office(s) with jurisdiction in the defined project area. Please read the introduction to each section that follows (Endangered Species, Migratory Birds, USFWS Facilities, and NWI Wetlands) for additional information applicable to the trust resources addressed in that section.

Location

Davidson County, Tennessee



Local office

Tennessee Ecological Services Field Office

☎ (931) 528-6481

📠 (931) 528-7075

446 Neal Street
Cookeville, TN 38501-4027

Endangered species

This resource list is for informational purposes only and does not constitute an analysis of project level impacts.

The primary information used to generate this list is the known or expected range of each species. Additional areas of influence (AOI) for species are also considered. An AOI includes areas outside of the species range if the species could be indirectly affected by activities in that area (e.g., placing a dam upstream of a fish population even if that fish does not occur at the dam site, may indirectly impact the species by reducing or eliminating water flow downstream). Because species can move, and site conditions can change, the species on this list are not guaranteed to be found on or near the project area. To fully determine any potential effects to species, additional site-specific and project-specific information is often required.

Section 7 of the Endangered Species Act **requires** Federal agencies to "request of the Secretary information whether any species which is listed or proposed to be listed may be present in the area of such proposed action" for any project that is conducted, permitted, funded, or licensed by any Federal agency. A letter from the local office and a species list which fulfills this requirement can **only** be obtained by requesting an official species list from either the Regulatory Review section in IPaC (see directions below) or from the local field office directly.

For project evaluations that require USFWS concurrence/review, please return to the IPaC website and request an official species list by doing the following:

1. Draw the project location and click CONTINUE.
2. Click DEFINE PROJECT.
3. Log in (if directed to do so).
4. Provide a name and description for your project.
5. Click REQUEST SPECIES LIST.

Listed species¹ and their critical habitats are managed by the [Ecological Services Program](#) of the U.S. Fish and Wildlife Service (USFWS) and the fisheries division of the National Oceanic and Atmospheric Administration (NOAA Fisheries²).

Species and critical habitats under the sole responsibility of NOAA Fisheries are not shown on this list. Please contact [NOAA Fisheries](#) for [species under their jurisdiction](#).

1. Species listed under the [Endangered Species Act](#) are threatened or endangered; IPaC also shows species that are candidates, or proposed, for listing. See the [listing status page](#) for more information. IPaC only shows species that are regulated by USFWS (see FAQ).
2. [NOAA Fisheries](#), also known as the National Marine Fisheries Service (NMFS), is an office of the National Oceanic and Atmospheric Administration within the Department of Commerce.

The following species are potentially affected by activities in this location:

Mammals

NAME	STATUS
Gray Bat <i>Myotis grisescens</i> Wherever found No critical habitat has been designated for this species. https://ecos.fws.gov/ecp/species/6329	Endangered
Indiana Bat <i>Myotis sodalis</i> Wherever found There is final critical habitat for this species. Your location does not overlap the critical habitat. https://ecos.fws.gov/ecp/species/5949	Endangered
Northern Long-eared Bat <i>Myotis septentrionalis</i> Wherever found No critical habitat has been designated for this species. https://ecos.fws.gov/ecp/species/9045	Endangered

Tricolored Bat *Perimyotis subflavus*

Proposed Endangered

Wherever found

No critical habitat has been designated for this species.

<https://ecos.fws.gov/ecp/species/10515>

Clams

NAME

STATUS

Cumberlandian Combshell *Epioblasma brevidens*

Endangered

There is **final** critical habitat for this species. Your location does not overlap the critical habitat.

<https://ecos.fws.gov/ecp/species/3119>

Orangefoot Pimpleback (pearlymussel) *Plethobasus cooperianus*

Endangered

Wherever found

No critical habitat has been designated for this species.

<https://ecos.fws.gov/ecp/species/1132>

Pink Mucket (pearlymussel) *Lampsilis abrupta*

Endangered

Wherever found

No critical habitat has been designated for this species.

<https://ecos.fws.gov/ecp/species/2629>

Ring Pink (mussel) *Obovaria retusa*

Endangered

Wherever found

No critical habitat has been designated for this species.

<https://ecos.fws.gov/ecp/species/1128>

Insects

NAME

STATUS

Monarch Butterfly *Danaus plexippus*

Candidate

Wherever found

No critical habitat has been designated for this species.

<https://ecos.fws.gov/ecp/species/3743>

Flowering Plants

NAME

STATUS

Braun's Rock-cress *Arabis perstellata*

Endangered

Wherever found

There is **final** critical habitat for this species. Your location does not overlap the critical habitat.

<https://ecos.fws.gov/ecp/species/4704>

Guthrie's (=pyne's) Ground-plum *Astragalus bibullatus*

Endangered

Wherever found

No critical habitat has been designated for this species.

<https://ecos.fws.gov/ecp/species/1739>

Leafy Prairie-clover *Dalea foliosa*

Endangered

No critical habitat has been designated for this species.

<https://ecos.fws.gov/ecp/species/5498>

Price's Potato-bean *Apios priceana* Threatened
 No critical habitat has been designated for this species.
<https://ecos.fws.gov/ecp/species/7422>

Short's Bladderpod *Physaria globosa* Endangered
 Wherever found
 There is **final** critical habitat for this species. Your location does not overlap the critical habitat.
<https://ecos.fws.gov/ecp/species/7206>

Critical habitats

Potential effects to critical habitat(s) in this location must be analyzed along with the endangered species themselves.

There are no critical habitats at this location.

Migratory birds

Certain birds are protected under the Migratory Bird Treaty Act¹ and the Bald and Golden Eagle Protection Act².

Any person or organization who plans or conducts activities that may result in impacts to migratory birds, eagles, and their habitats should follow appropriate regulations and consider implementing appropriate conservation measures, as described [below](#).

1. The [Migratory Birds Treaty Act](#) of 1918.
2. The [Bald and Golden Eagle Protection Act](#) of 1940.

Additional information can be found using the following links:

- Birds of Conservation Concern <https://www.fws.gov/program/migratory-birds/species>
- Measures for avoiding and minimizing impacts to birds <https://www.fws.gov/library/collections/avoiding-and-minimizing-incident-take-migratory-birds>
- Nationwide conservation measures for birds <https://www.fws.gov/sites/default/files/documents/nationwide-standard-conservation-measures.pdf>

The birds listed below are birds of particular concern either because they occur on the [USFWS Birds of Conservation Concern](#) (BCC) list or warrant special attention in your project location. To learn more about the levels of concern for birds on your list and how this list is generated, see the FAQ [below](#). This is not a list of every bird you may find in this location, nor a guarantee that every bird on this list will be found in your project area. To see exact locations of where birders and the general public have sighted birds in and around your project area, visit the [E-bird data mapping tool](#) (Tip: enter your location, desired date range and a species on your list). For projects that occur off the Atlantic Coast, additional maps and models detailing the relative occurrence and abundance of bird species on your list are available. Links to additional information about Atlantic Coast birds, and other important information about your migratory bird list, including how to properly interpret and use your migratory bird report, can be found [below](#).

For guidance on when to schedule activities or implement avoidance and minimization measures to reduce impacts to migratory birds on your list, click on the PROBABILITY OF PRESENCE SUMMARY at the top of your list to see when these birds are most likely to be present and breeding in your project area.

NAME

BREEDING SEASON

Bald Eagle *Haliaeetus leucocephalus*

Breeds Sep 1 to Jul 31

This is not a Bird of Conservation Concern (BCC) in this area, but warrants attention because of the Eagle Act or for potential susceptibilities in offshore areas from certain types of development or activities.

Chimney Swift <i>Chaetura pelagica</i> This is a Bird of Conservation Concern (BCC) throughout its range in the continental USA and Alaska.	Breeds Mar 15 to Aug 25
Field Sparrow <i>Spizella pusilla</i> This is a Bird of Conservation Concern (BCC) only in particular Bird Conservation Regions (BCRs) in the continental USA	Breeds Mar 1 to Aug 15
Lesser Yellowlegs <i>Tringa flavipes</i> This is a Bird of Conservation Concern (BCC) throughout its range in the continental USA and Alaska. https://ecos.fws.gov/ecp/species/9679	Breeds elsewhere
Prairie Warbler <i>Dendroica discolor</i> This is a Bird of Conservation Concern (BCC) throughout its range in the continental USA and Alaska.	Breeds May 1 to Jul 31
Prothonotary Warbler <i>Protonotaria citrea</i> This is a Bird of Conservation Concern (BCC) throughout its range in the continental USA and Alaska.	Breeds Apr 1 to Jul 31
Red-headed Woodpecker <i>Melanerpes erythrocephalus</i> This is a Bird of Conservation Concern (BCC) throughout its range in the continental USA and Alaska.	Breeds May 10 to Sep 10
Rusty Blackbird <i>Euphagus carolinus</i> This is a Bird of Conservation Concern (BCC) only in particular Bird Conservation Regions (BCRs) in the continental USA.	Breeds elsewhere
Wood Thrush <i>Hylocichla mustelina</i> This is a Bird of Conservation Concern (BCC) throughout its range in the continental USA and Alaska.	Breeds May 10 to Aug 31

Probability of Presence Summary

The graphs below provide our best understanding of when birds of concern are most likely to be present in your project area. This information can be used to tailor and schedule your project activities to avoid or minimize impacts to birds. Please make sure you read and understand the FAQ "Proper Interpretation and Use of Your Migratory Bird Report" before using or attempting to interpret this report.

Probability of Presence (1)

Each green bar represents the bird's relative probability of presence in the 10km grid cell(s) your project overlaps during a particular week of the year. (A year is represented as 12 4-week months.) A taller bar indicates a higher probability of species presence. The survey effort (see below) can be used to establish a level of confidence in the presence score. One can have higher confidence in the presence score if the corresponding survey effort is also high.

How is the probability of presence score calculated? The calculation is done in three steps:

1. The probability of presence for each week is calculated as the number of survey events in the week where the species was detected divided by the total number of survey events for that week. For example, if in week 12 there were 20 survey events and the Spotted Towhee was found in 5 of them, the probability of presence of the Spotted Towhee in week 12 is 0.25.
2. To properly present the pattern of presence across the year, the relative probability of presence is calculated. This is the probability of presence divided by the maximum probability of presence across all weeks. For example, imagine the probability of presence in week 20 for the Spotted Towhee is 0.05, and that the probability of presence at week 12 (0.25) is the maximum of any week of the year. The relative probability of presence on week 12 is $0.25/0.25 = 1$; at week 20 it is $0.05/0.25 = 0.2$.

3. The relative probability of presence calculated in the previous step undergoes a statistical conversion so that all possible values fall between 0 and 10, inclusive. This is the probability of presence score.

To see a bar's probability of presence score, simply hover your mouse cursor over the bar.

Breeding Season (■)

Yellow bars denote a very liberal estimate of the time-frame inside which the bird breeds across its entire range. If there are no yellow bars shown for a bird, it does not breed in your project area.

Survey Effort (|)

Vertical black lines superimposed on probability of presence bars indicate the number of surveys performed for that species in the 10km grid cell(s) your project area overlaps. The number of surveys is expressed as a range, for example, 33 to 64 surveys.

To see a bar's survey effort range, simply hover your mouse cursor over the bar.

No Data (-)

A week is marked as having no data if there were no survey events for that week.

Survey Timeframe

Surveys from only the last 10 years are used in order to ensure delivery of currently relevant information. The exception to this is areas off the Atlantic coast, where bird returns are based on all years of available data, since data in these areas is currently much more sparse.

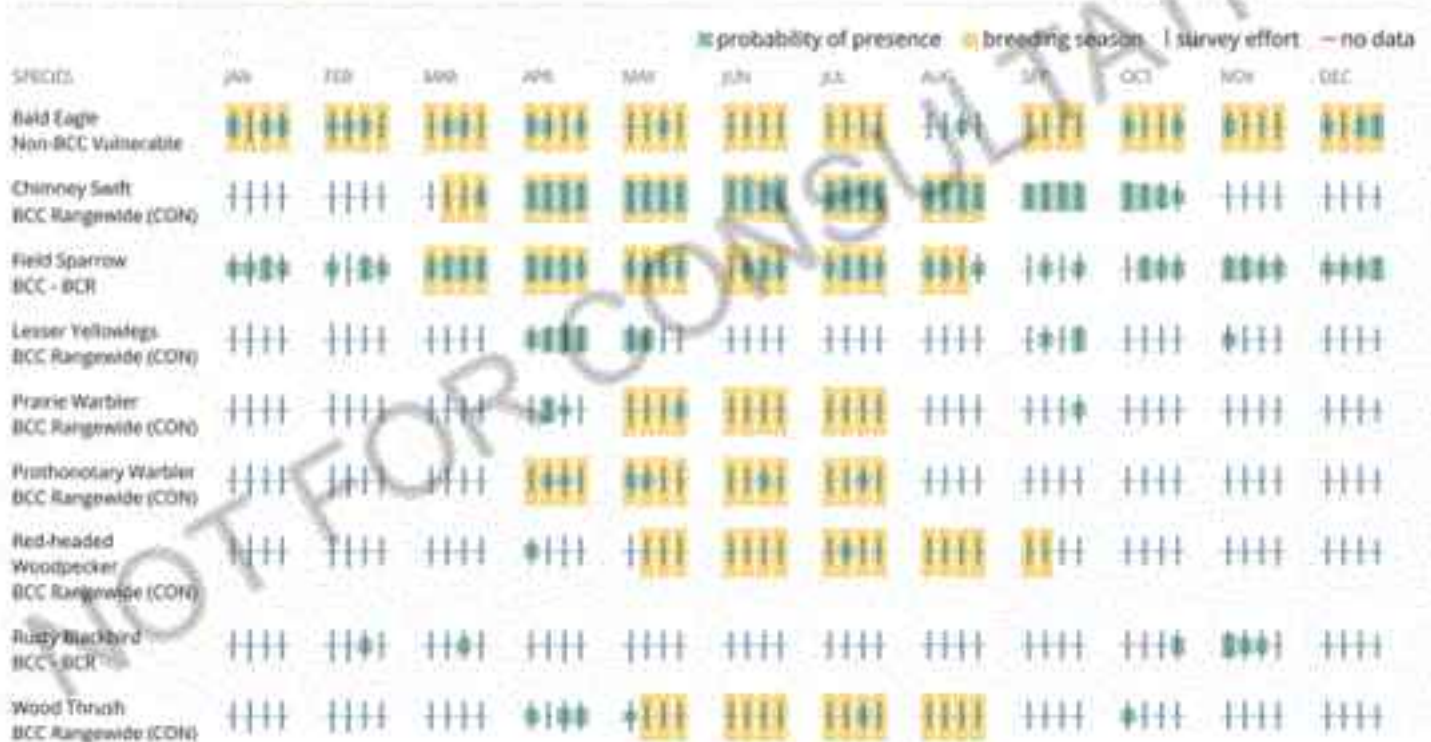

Tell me more about conservation measures I can implement to avoid or minimize impacts to migratory birds.

[Nationwide Conservation Measures](#) describes measures that can help avoid and minimize impacts to all birds at any location year round. Implementation of these measures is particularly important when birds are most likely to occur in the project area. When birds may be breeding in the area, identifying the locations of any active nests and avoiding their destruction is a very helpful impact minimization measure. To see when birds are most likely to occur and be breeding in your project area, view the Probability of Presence Summary. [Additional measures](#) or [permits](#) may be advisable depending on the type of activity you are conducting and the type of infrastructure or bird species present on your project site.

What does IPaC use to generate the list of migratory birds that potentially occur in my specified location?

The Migratory Bird Resource List is comprised of USFWS [Birds of Conservation Concern \(BCC\)](#) and other species that may warrant special attention in your project location.

The migratory bird list generated for your project is derived from data provided by the [Avian Knowledge Network \(AKN\)](#). The AKN data is based on a growing collection of [survey, banding, and citizen science datasets](#) and is queried and filtered to return a list of those birds reported as occurring in the 10km grid cell(s) which your project intersects, and that have been identified as warranting special attention because they are a BCC species in that area, an eagle ([Eagle Act](#) requirements may apply), or a species that has a particular vulnerability to offshore activities or development.

Again, the Migratory Bird Resource list includes only a subset of birds that may occur in your project area. It is not representative of all birds that may occur in your project area. To get a list of all birds potentially present in your project area, please visit the [Rapid Avian Information Locator \(RAIL\) Tool](#).

What does IPaC use to generate the probability of presence graphs for the migratory birds potentially occurring in my specified location?

The probability of presence graphs associated with your migratory bird list are based on data provided by the [Avian Knowledge Network \(AKN\)](#). This data is derived from a growing collection of [survey, banding, and citizen science datasets](#).

Probability of presence data is continuously being updated as new and better information becomes available. To learn more about how the probability of presence graphs are produced and how to interpret them, go the Probability of Presence Summary and then click on the "Tell me about these graphs" link.

How do I know if a bird is breeding, wintering or migrating in my area?

To see what part of a particular bird's range your project area falls within (i.e. breeding, wintering, migrating or year-round), you may query your location using the [RAIL Tool](#) and look at the range maps provided for birds in your area at the bottom of the profiles provided for each bird in your results. If a bird on your migratory bird species list has a breeding season associated with it, if that bird does occur in your project area, there may be nests present at some point within the timeframe specified. If "Breeds elsewhere" is indicated, then the bird likely does not breed in your project area.

What are the levels of concern for migratory birds?

Migratory birds delivered through IPaC fall into the following distinct categories of concern:

1. "BCC Rangewide" birds are [Birds of Conservation Concern](#) (BCC) that are of concern throughout their range anywhere within the USA (including Hawaii, the Pacific Islands, Puerto Rico, and the Virgin Islands);
2. "BCC - BCR" birds are BCCs that are of concern only in particular Bird Conservation Regions (BCRs) in the continental USA; and
3. "Non-BCC - Vulnerable" birds are not BCC species in your project area, but appear on your list either because of the [Eagle Act](#) requirements (for eagles) or (for non-eagles) potential susceptibilities in offshore areas from certain types of development or activities (e.g. offshore energy development or longline fishing).

Although it is important to try to avoid and minimize impacts to all birds, efforts should be made, in particular, to avoid and minimize impacts to the birds on this list, especially eagles and BCC species of rangewide concern. For more information on conservation measures you can implement to help avoid and minimize migratory bird impacts and requirements for eagles, please see the FAQs for these topics.

Details about birds that are potentially affected by offshore projects

For additional details about the relative occurrence and abundance of both individual bird species and groups of bird species within your project area off the Atlantic Coast, please visit the [Northeast Ocean Data Portal](#). The Portal also offers data and information about other taxa besides birds that may be helpful to you in your project review. Alternately, you may download the bird model results files underlying the portal maps through the [NOAA NCCOS Interactive Statistical Modeling and Predictive Mapping of Marine Bird Distributions and Abundance on the Atlantic Outer Continental Shelf](#) project webpage.

Bird tracking data can also provide additional details about occurrence and habitat use throughout the year, including migration. Models relying on survey data may not include this information. For additional information on marine bird tracking data, see the [Diving Bird Study](#) and the [nanotag studies](#) or contact [Caleb Spiegel](#) or [Pam Loring](#).

What if I have eagles on my list?

If your project has the potential to disturb or kill eagles, you may need to [obtain a permit](#) to avoid violating the Eagle Act should such impacts occur.

Proper Interpretation and Use of Your Migratory Bird Report

The migratory bird list generated is not a list of all birds in your project area, only a subset of birds of priority concern. To learn more about how your list is generated, and see options for identifying what other birds may be in your project area, please see the FAQ "What does IPaC use to generate the migratory birds potentially occurring in my specified location". Please be aware this report provides the "probability of presence" of birds within the 10 km grid cell(s) that overlap your project; not your exact project footprint. On the graphs provided, please also look carefully at the survey effort (indicated by the black vertical bar) and for the existence of the "no data" indicator (a red horizontal bar). A high survey effort is the key component. If the survey effort is high, then the probability of presence score can be viewed as more dependable. In contrast, a low survey effort bar or no data bar means a lack of data and, therefore, a lack of certainty about presence of the species. This list is not perfect; it is

simply a starting point for identifying what birds of concern have the potential to be in your project area, when they might be there, and if they might be breeding (which means nests might be present). The list helps you know what to look for to confirm presence, and helps guide you in knowing when to implement conservation measures to avoid or minimize potential impacts from your project activities, should presence be confirmed. To learn more about conservation measures, visit the FAQ "Tell me about conservation measures I can implement to avoid or minimize impacts to migratory birds" at the bottom of your migratory bird trust resources page.

Facilities

National Wildlife Refuge lands

Any activity proposed on lands managed by the [National Wildlife Refuge](#) system must undergo a 'Compatibility Determination' conducted by the Refuge. Please contact the individual Refuges to discuss any questions or concerns.

There are no refuge lands at this location.

Fish hatcheries

There are no fish hatcheries at this location.

Wetlands in the National Wetlands Inventory (NWI)

Impacts to [NWI wetlands](#) and other aquatic habitats may be subject to regulation under Section 404 of the Clean Water Act, or other State/Federal statutes.

For more information please contact the Regulatory Program of the local [U.S. Army Corps of Engineers District](#).

This location did not intersect any wetlands mapped by NWI.

NOTE: This initial screening does not replace an on-site delineation to determine whether wetlands occur. Additional information on the NWI data is provided below.

Data limitations

The Service's objective of mapping wetlands and deepwater habitats is to produce reconnaissance level information on the location, type and size of these resources. The maps are prepared from the analysis of high altitude imagery. Wetlands are identified based on vegetation, visible hydrology and geography. A margin of error is inherent in the use of imagery; thus, detailed on-the-ground inspection of any particular site may result in revision of the wetland boundaries or classification established through image analysis.

The accuracy of image interpretation depends on the quality of the imagery, the experience of the image analysts, the amount and quality of the collateral data and the amount of ground truth verification work conducted. Metadata should be consulted to determine the date of the source imagery used and any mapping problems.

Wetlands or other mapped features may have changed since the date of the imagery or field work. There may be occasional differences in polygon boundaries or classifications between the information depicted on the map and the actual conditions on site.

Data exclusions

Certain wetland habitats are excluded from the National mapping program because of the limitations of aerial imagery as the primary data source used to detect wetlands. These habitats include seagrasses or submerged aquatic vegetation that are found in the intertidal and subtidal zones of estuaries and nearshore coastal waters. Some deepwater reef communities (coral or tubercid worm reefs) have also been excluded from the inventory. These habitats, because of their depth, go undetected by aerial imagery.

Data precautions

Federal, state, and local regulatory agencies with jurisdiction over wetlands may define and describe wetlands in a different manner than that used in this inventory. There is no attempt, in either the design or products of this inventory, to define the limits of proprietary jurisdiction of any Federal, state, or local government or to establish the geographical scope of the regulatory programs of government agencies. Persons intending to engage in activities involving modifications within or adjacent to wetland areas should seek the advice of appropriate Federal, state, or local agencies concerning specified agency regulatory programs and proprietary jurisdictions that may affect such activities.

NOT FOR CONSULTATION

**APPENDIX 7 –
Financial Assurance**

Financial Assurance

The proposed Triune Centennial Processing Facility is currently operating under a Recovered Materials Processing Facility (RMPF) designation. The facility, TBG Recovered Materials Facility, currently accepts cardboard, plastics, glass, scrap tires, food grade grease, roofing shingles, scrap metal, waste from construction, remodeling, repairing and demolition of structures and from road building and general recycling operations on the site.

As part of the RMPF approval process, TDEC requires that financial assurance be posted by the applicant. A total amount of \$152,130.00 is currently posted for the RMPF facility, and the posted financial assurance documents are attached as part of **Appendix 7**. The proposed Triune Centennial Processing Facility will utilize the same waste storage areas as part of the facility operations and use the currently posted amount as its financial assurance for the Permit-By-Rule application.

**RECOVERED MATERIALS PROCESSING FACILITY
FINANCIAL ASSURANCE WORKSHEET**

FACILITY NAME: TBG Recovered Materials Facility - 7211 Centennial

1. The maximum storage capacity for solid waste in cubic yards:
Attach a sketch and/or calculation to support this number.

C&D average weight of 350 lbs./CY per industry documentation
6850 CY for total possible building storage
2 piles 146' x 65' x 15' tall with additional storage
possible around equipment estimated at a total of 6,850 CY
3000 CY for possible outdoor container storage

9850 yd³ or ~1725 tons

2. The cost of transporting to a disposal site (The cost per yd³ times the amount shown above.):

Converted to tons per above formula @ \$25 per ton

\$ 43,125

3. The cost (tipping fee, surcharges, etc.) to dispose of this volume of waste:

Using TDEC's \$34 per ton gate rate provided 8/2/2022

\$ 58,650

4. Mobilization of equipment's and Labor cost

\$ 25,000

5. Items 2+3+4= Total cost.

\$ 126,775

6. Contingency 20%

\$ 25,355

Total Amount Due

\$ 152,130

Signed _____

To the best of my knowledge, the above
information is correct and complete.



NOTES:

- 1. PROPERTY BOUNDARIES ARE SHOWN FOR REFERENCE PURPOSES ONLY. LINES ARE BASED ON STATE OF TENNESSEE PROPERTY VIEWER AND ARE APPROXIMATE.
- 2. AERIAL IMAGERY SHOWN IS PROVIDED BY MICROSOFT CORPORATION, DATED 2022.

LEGEND

- PROPOSED**
- PROPOSED WASTE BOUNDARY
 - CONCRETE PATHWAY
 - TRAFFIC FLOW ARROW

- EXISTING**
- PROPERTY BOUNDARY
 - OVERHEAD POWER LINE
 - FENCELINE

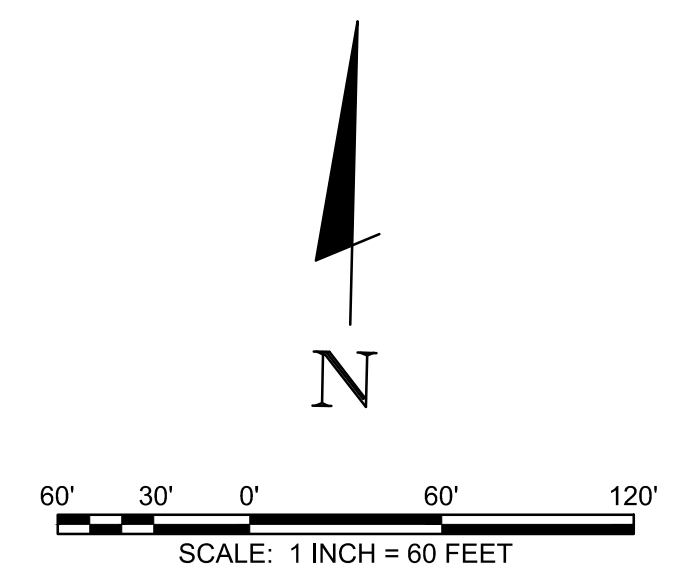

PRELIMINARY
NOT FOR
CONSTRUCTION

DATE

STORAGE AREAS
TBG MATERIAL RECOVERY PROCESSING FACILITY
TRINITY BUSINESS GROUP
NASHVILLE, TN

REVISION INFORMATION	
REV.	DESCRIPTION

**APPENDIX 8 –
Facility Calculations**

A8-1 Noise Sampling Survey

A8-2 Transportation Infrastructure Impact

Noise Sampling Survey

Noise Sampling Survey

The proposed facility operations will solely take place inside the building at the facility and thereby reduce noise potential. The existing site's location in a purely industrial area limits its impact on the surrounding area. A Noise Sampling Survey was conducted by Barge in December 2022 to show existing noise levels from Centennial Boulevard, Tune Airport, and helicopter training traffic as well as adjacent industrial activity to the site. The results of the survey are shown on the table below and the location of each measurement can be seen on the attached exhibit.

Noise Level of Surrounding Property				
Location	Measurement Period (minutes)	LAeq (dB)	LCpeak (dB)	Max Level (dB)
SM-1	5:01	62.2	104.8	76.7
SM-2	5:02	55.3	100.9	79
SM-3	5:02	63.2	111.4	84.2
SM-4	5:01	67.6	113.8	87.1
SM-5	5:01	61.2	113.5	89.9

Table 1. Noise Sampling Survey

Sound is measured in decibels (dB). According to the CDC, a whisper is about 30 dB, normal conversation is about 60 dB, and a motorcycle engine running is about 95 dB. Noise above 70 dB over a prolonged period of time may start to damage the hearing of a person.

Noise Sampling Metrics

LAeq is the constant noise level (dB) that would result in the same total sound energy being produced over a given period.

LCpeak is used for occupational noise measurement where loud bangs are present and is simply the highest value measured over a given period of time. C-Weighted peak measurements look at the effect of low-frequency sounds on the human ear.

Max level is the maximum RMS (root mean square) sound level. The RMS is the essentially the "average" value of the pressure. **Max level** pressure measurements give a better picture of the general maximum noise level while **LCpeak** measurement gives the maximum pressure recorded during the sampling survey.



Noise Level of Surrounding Property				
Location	Measurement Period (minutes)	Laeq (dB)	Lcpeak (dB)	Max Level (dB)
SM-1	5:01	62.2	104.8	76.7
SM-2	5:02	55.3	100.9	79
SM-3	5:02	63.2	111.4	84.2
SM-4	5:01	67.6	113.8	87.1
SM-5	5:01	61.2	113.5	89.9

NOTES:

1. NOISE SAMPLING SURVEY WAS PERFORMED BY BARGE IN DECEMBER 2022.

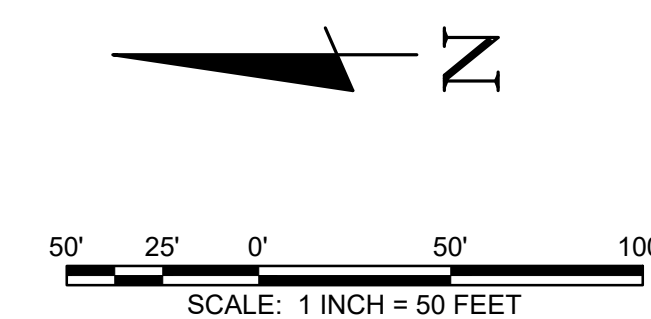

PRELIMINARY
NOT FOR
CONSTRUCTION

DATE

NOISE SAMPLING

TRIUNE CENTENNIAL PROCESSING FACILITY
TRIUNE RESIDUALS MANAGEMENT, LLC
7133 CENTENNIAL BLVD NASHVILLE, TN

REVISION INFORMATION

DESCRIPTION

REV. | DR. | CHK. | DATE

EX

FILE NO. 3712202

Transportation Infrastructure Impact

Transportation Infrastructure Impact

Trip Generation

The proposed waste processing facility is anticipated to generate 20 additional vehicles per day accessing the site. This estimate is based on the current facility operations under the Recovered Material Processing Facility (RMPF) designation. The inbound and outbound trucks are anticipated to ingress and egress from the site by utilizing Centennial Boulevard and Briley Parkway.

Level of Service

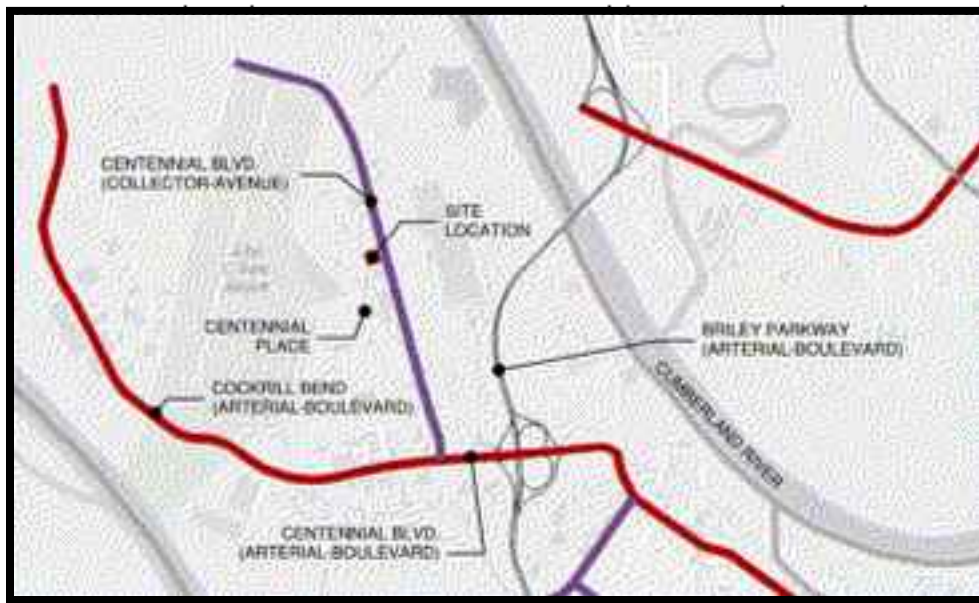

Figure 1. Nashville Major and Collector Street Plan

According to the Nashville Major and Collector Street Plan, Centennial Boulevard is classified as a Collector-Avenue along the location of the proposed facility. Collector-Avenues are normally relatively low-speed, low- to medium-volume streets that usually serve short trips and are intended for collecting trips from local streets and distributing them to the Arterial-Boulevard network. The speed limit is 50 mph on Centennial Boulevard until it intersects with Centennial Place. The speed limit is lowered to 40 mph from this point to Briley Parkway. The road includes two travel lanes with a turn lane before widening at the intersection with Cockrill Bend, where it is reclassified as an Arterial-Boulevard.

Briley Parkway is also classified as an Arterial-Boulevard by the Nashville Major and Collector Street Plan. Arterial-Boulevards usually serve longer trips with medium to high volume and area intended to collect trips from Collector-Avenues and distribute them to the larger network. Briley Parkway includes two travel lanes in each direction with a median, and the posted speed limit is 55 mph. A TDOT count station, 19000318, located on Briley Parkway just south of Centennial Boulevard listed the annual average daily traffic (AADT) as 47,778 vehicles per day for 2021.

Conclusion

The proposed waste processing facility is anticipated to generate 20 additional vehicles per site accessing the site located at 7133 Centennial Boulevard. Based on the anticipated facility traffic being a small fraction of the adjacent road's capacity, the proposed facility trips will not cause a significant degradation of the level of service on Centennial Boulevard or Briley Parkway.